

“Toshkent irrigatsiya va qishloq  
xo’jaligini mexanizatsiyalash  
muhandislari instituti”  
Milliy tadqiqot universiteti



## **Termodinamika va Issiqlik uzatish asoslari fani**

**Mavzu:  
Sovutish qurilmalari va issiqlik  
nasoslari sikllari**



**texnika fanlari nomzodi, dotsenti  
Nuritov Ikrom Rajabovich**



# Sovutish qurilmalari va issiqlik nasoslari sikllari

*Reja:*

- 1. Umumiy ma'lumotlar.*
- 2. Bug' kompressiyali sovitish qurilmasi sikli.*
- 3. Issiqlik nasos sikli.*

## FOYDALANILGAN ADABIYOTLAR

1. Joseph M Powers. LECTURE NOTES ON THERMODYNAMICS. Department of Aerospace and Mechanical Engineering University of Notre Dame, Notre Dame, Indiana 46556-5637, USA, updated 01 July 2014.
  3. R.A.Zohidov, M.M.Alimova, Sh.S.Mavjudova. Issiqlik texnikasi (darslik). – T.: “O’zbekiston faylasuflari milliy jamiyati” nashriyoti, 2010. – 200 b.
  4. T.S.Xudoyberdiev, B.P.Shaymardanov, R.A.Abduraxmonov, A.N.Xudoyorov, B.R.Boltaboyev. Issiqlik texnikasi asoslari (darslik)–T.: “Cho’lpon” nashriyoti, 2008. – 216 b.
  5. Ш. Ж. Имомов, И. Р. Нуритов, К.Э.Усмонов. Сборник задач по основам термодинамики и теплопередачи /Учебное пособие–Т.:ТИИИМСХ.2021.-116 с.
- <https://m.youtube.com/watch?v=TRhEUlxJals>
- <https://resh.edu.ru/subject/lesson/5897/main/150908/>
- [https://eti.su/articles/over/over\\_1534.html](https://eti.su/articles/over/over_1534.html)

# Bug' kuch qurilmalarining sikllari

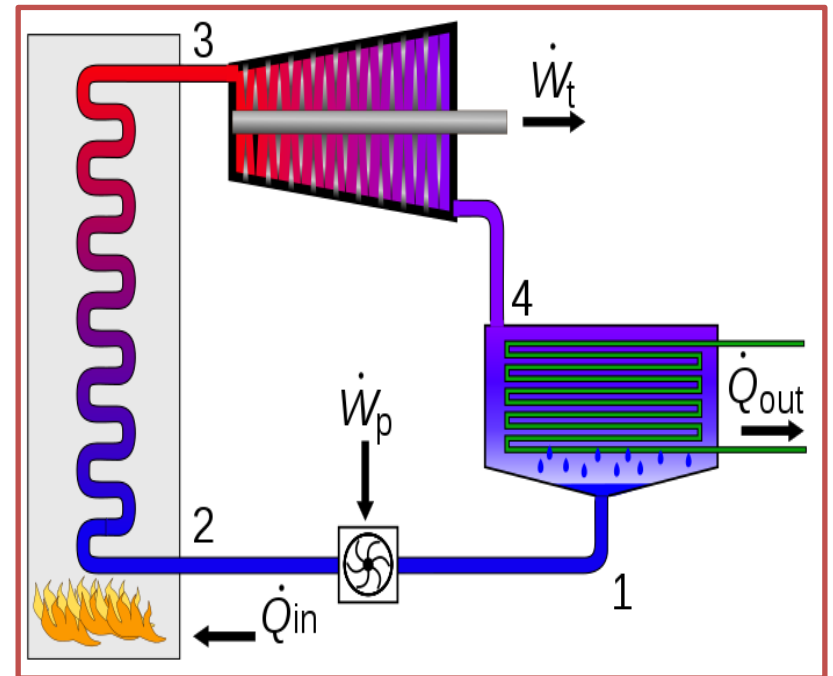
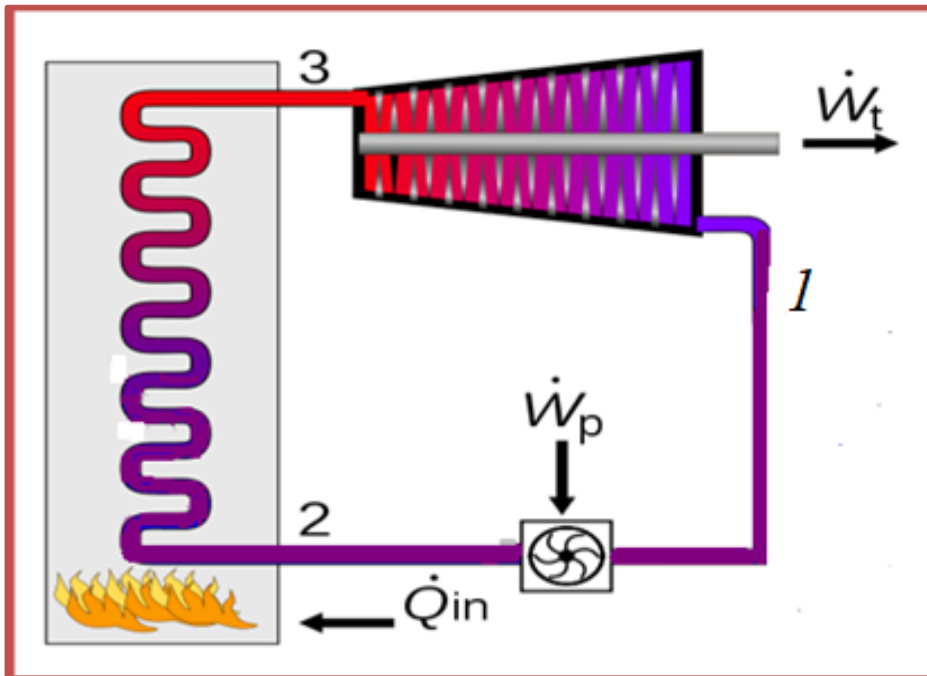
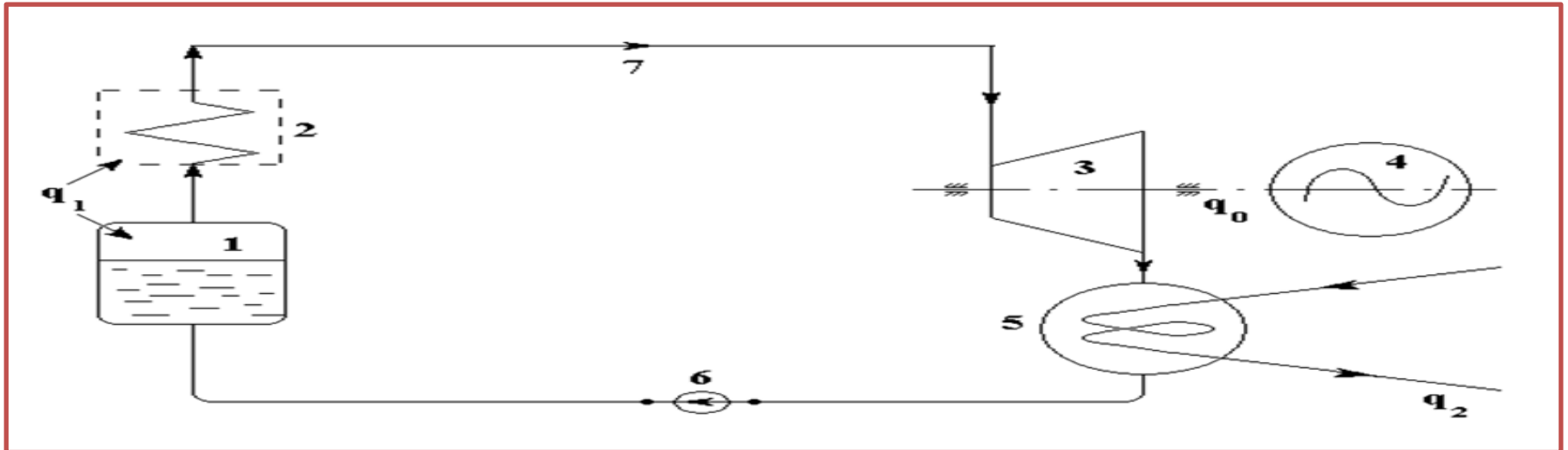

## 1. Umumiy ma'lumotlar.

Qishloq xo'jaligi ishlab chiqarishining ko'pgina sohalarida, **masalan**, qishloq xo'jalik mahsulotlarini saqlashda, hamda boshqa texnologik jarayonlarda haroratni o'rab turuvchi muhit haroratidan ancha past darajada ushlab turish kerak bo'ladi.



Ba'zida past haroratli muhitdan yuqori haroratli muhitga issiqlik haydash kerak bo'ladi. Jismning haroratini o'rab turuvchi muhit haroratidan pastroq qiymatga tushirish va uni talab qilinadigan darajada ushlab turish uchun sovitish qurilmalari qo'llaniladi.



O'rab turuvchi muhitdan issiqlik olib va uni yuqoriroq haroratli muhitga uzatishga mo'ljallangan sovitish qurilmalari **issiqlik nasoslari** deyiladi.

Sovitilayotgan jismdan vaqt birligida (bir soatda) ajralayotgan issiqlik miqdori sovitish qurilmasining **sovitish quvvati** deyiladi.

**1kg** sovitish agenti (ishchi jism) ga berilgan sovitish quvvati **sovitish agentining solishtirma sovitish quvvati** deyiladi.



Teskari sikl samarasini tavsiflash uchun sovitish koeffitsienti  $\epsilon_x$  tushunchasi kiritiladi:

$$\epsilon_x = \frac{q_2}{l_y} = \frac{q_2}{q_1 - q_2}$$

bunda  $q_1$ ,  $q_2$  – siklga kiritilayotgan va chiqarilayotgan issiqlik miqdori;  $l_{ts}$  – sikl ishi.

Ishchi jism (sovitish agentlari) sifatida past haroratda qaynovchi deb ataladigan suyuqliklar qo'llaniladi.

**Sovitish agenti sifatida xlor metil  $CN_3Cl$ ,  $CO_2$  gazi, ammiak  $NH_3$  va asosan freonlar – ftorxlor uglevodorodning birikmalari.**



-\_ХОЛОДИЛЬНИКНИНГ ИШ ПРИЦИП.трг4



ХОЛОДИЛНИКНИНГ КОМПРЕССОР БИЛАН ИШ ПРИНЦИПИ.MP4



Sanoatda sun'iy sovuq olishda birinchi marotaba sovitish qurilmasida ishchi jism sifatida **havo** ishlatilgan.

***Asosiy kamchiligi*** – sikl kam samarali bo'lib, o'ta chegaralangan qo'llanish sohasiga ega bo'lgan.

Qishloq xo'jaligida kompressorli qurilmalar keng tarqaldi.

## ***2. Bug' kompressiyali sovitish qurilmasi sikli.***

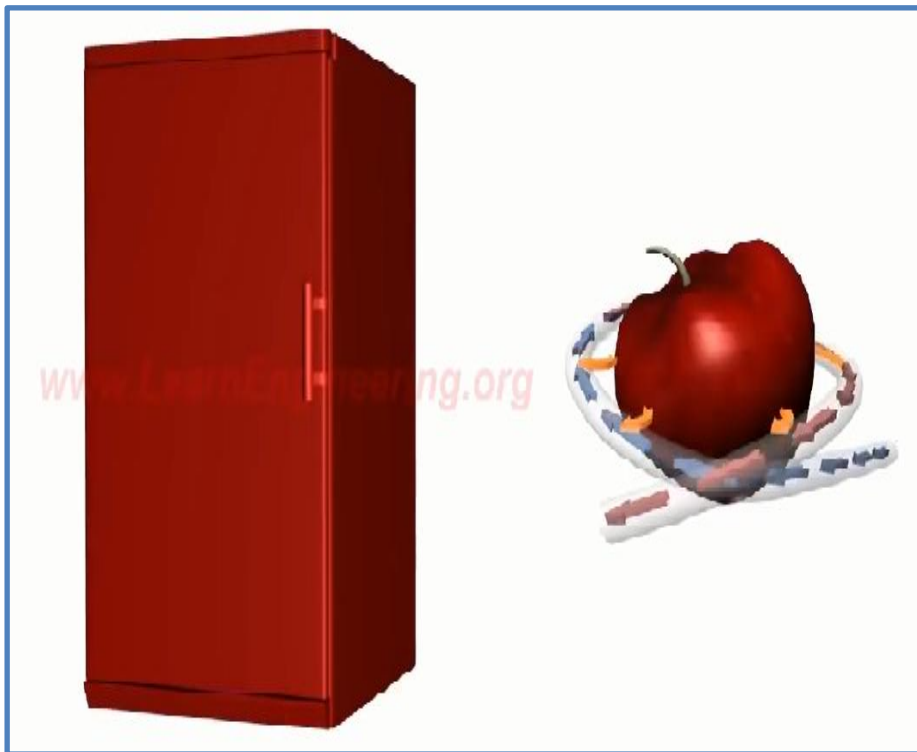

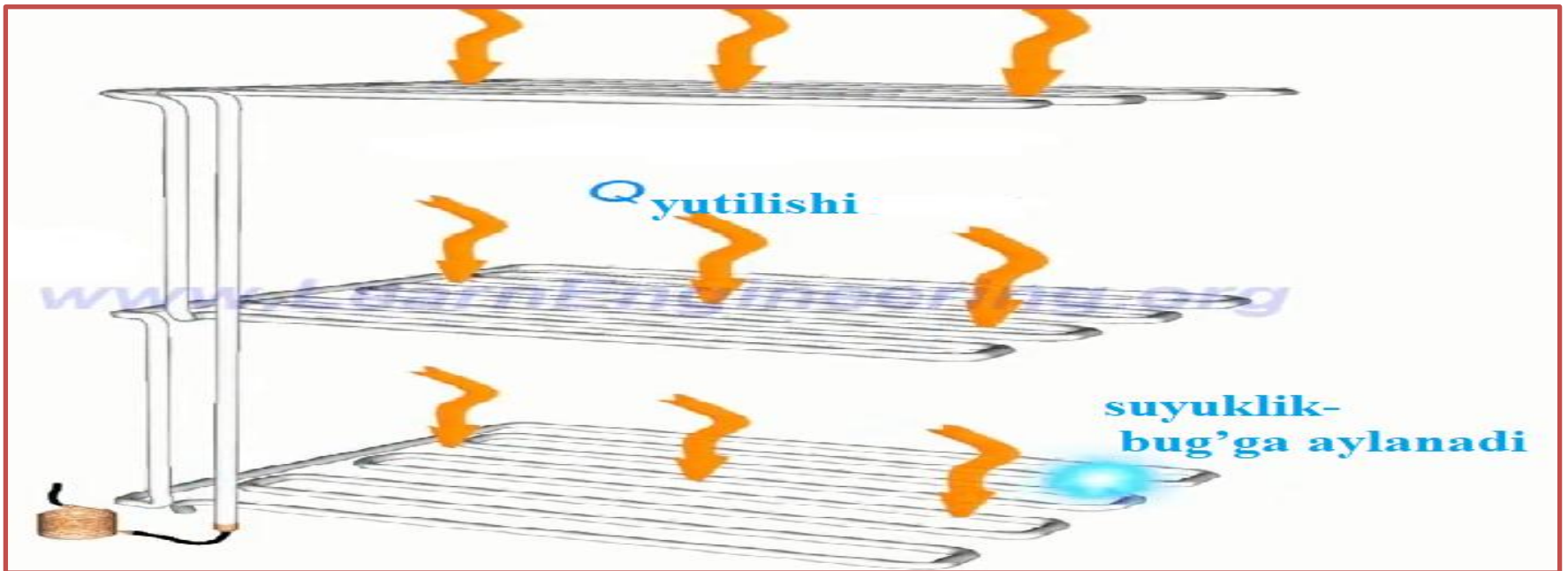

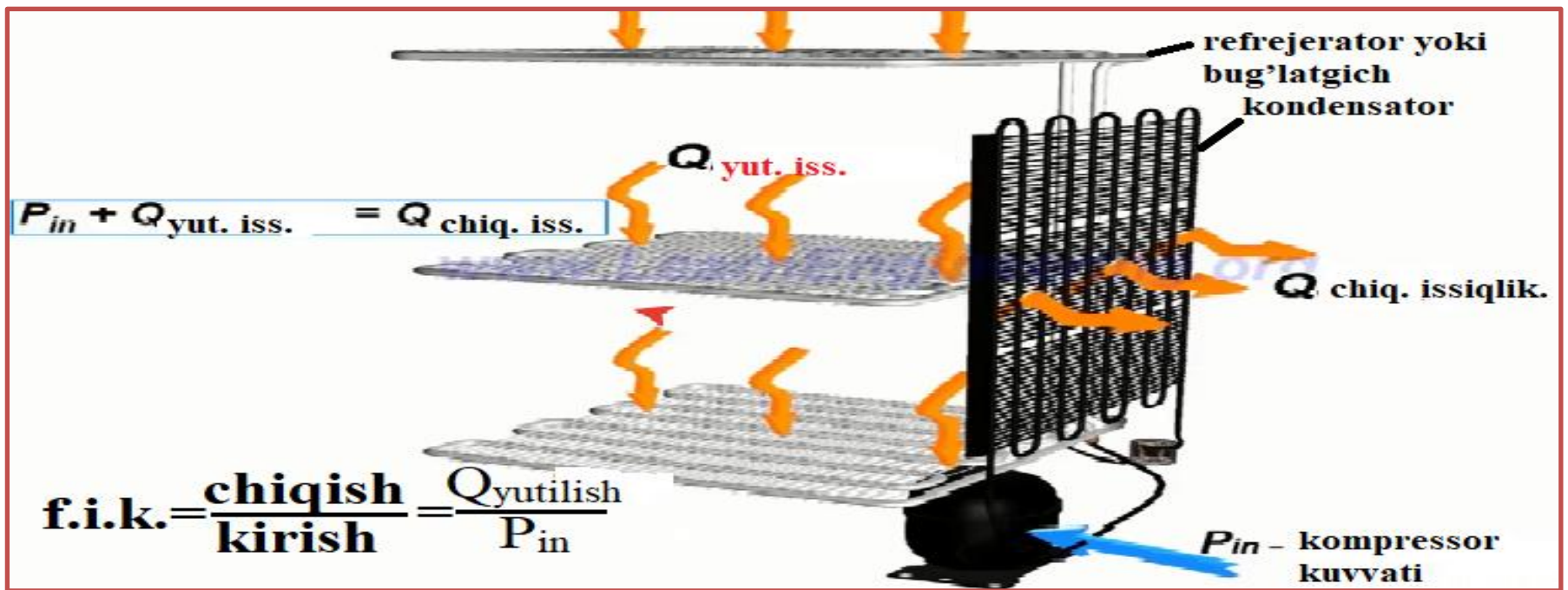
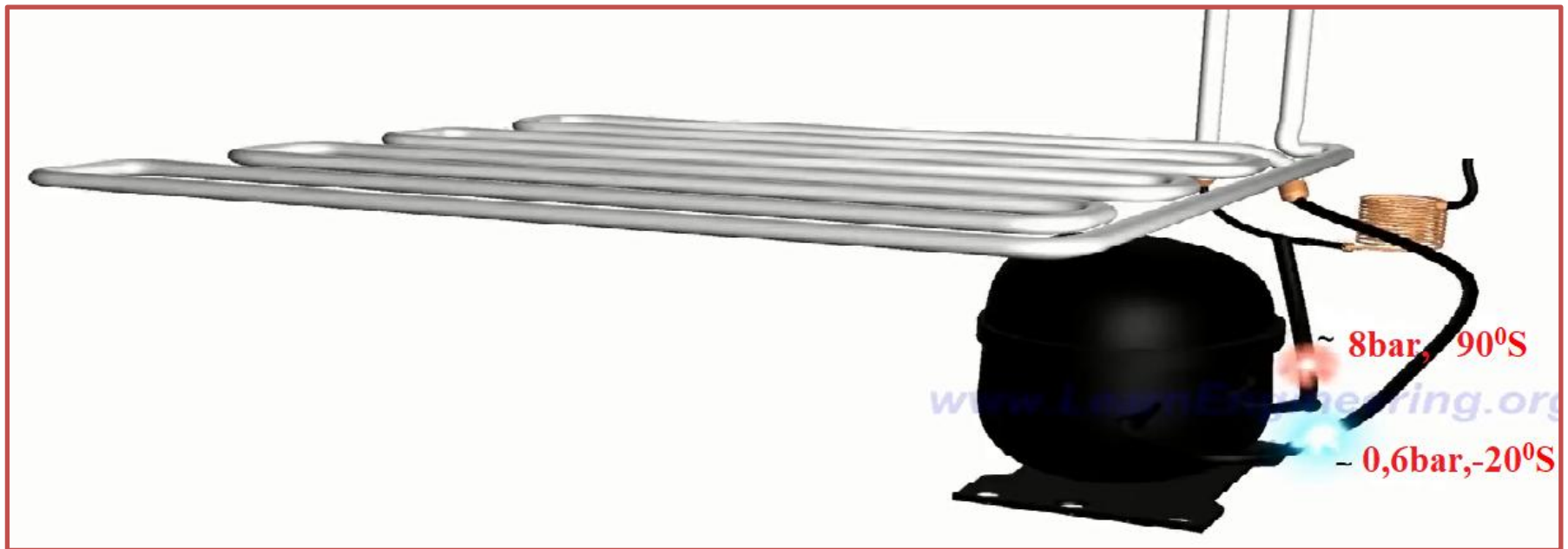

Qurilmaning shartli sxemasi rasmda tasvirlangan. Ushbu shaklda siklning  $Ts$  – koordinatalardagi diagrammasi keltirilgan (sxema va diagrammadagi nuqtalar mos keladi).

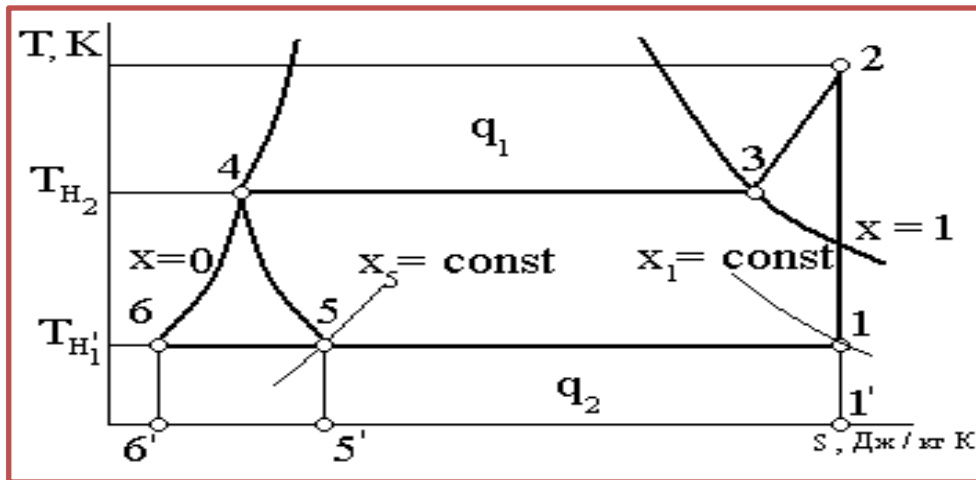
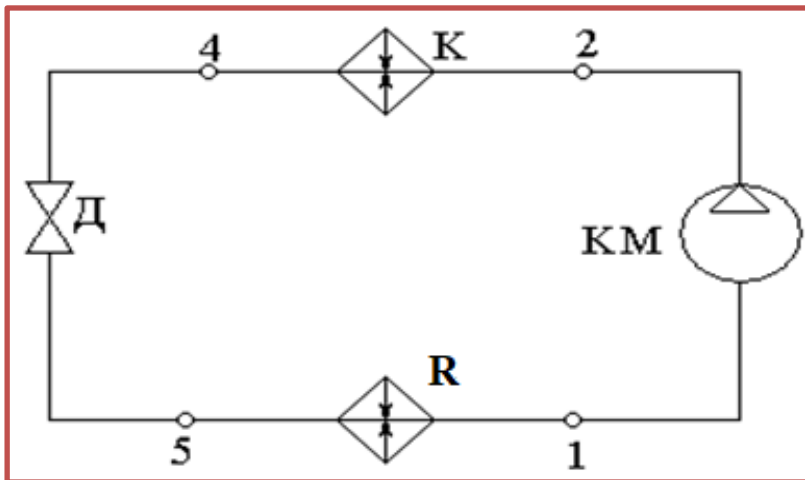

Bug' kompressiyali sovitish qurilmasi shartli sxemasi va siklning  $Ts$ -koordinatalardagi diagrammasi:  $KM$ -kompressor;  $K$ -kondensator;  $D$ -drossel klapani;  $R$ -refrejerator yoki bug'latgich .

Bu qurilmaning sovitish koeffitsienti:

$h_5=h_4$  ekanligini hisobga olib, topamiz:  $(h_2-h_1)$  – kompressorda sarf bo'lgan ish.

$$\varepsilon_x = \frac{q_2}{q_1 - q_2} = \frac{h_1 - h_5}{(h_2 - h_4) - (h_1 - h_5)}$$

$$\varepsilon_x = \frac{h_1 - h_5}{h_2 - h_1}$$

### ***3. Issiqlik nasos sikli.***

Har xil haroratli jismlarning biridan ikkinchisiga issiqlik uzatishga mo'ljallangan uskunalar ***issiqlik transformatorlari (thermo-transformatorlar)*** deyiladi.

Past haroratli jismlardan yuqori haroratli jismlarga issiqlik uzatishga hizmat qiladigan issiqlik transformatorlari ***kuchaytiruvchi transformatorlar*** deyiladi.

Ularga ***issiqlik nasoslari kiradi***, issiqlik nasoslari o'rab turuvchi muhitdan yuqori haroratli ob'ektga issiqlik uzatishni amalga oshiradi.

**Masalan**, agar sovitgich qurilmalari uchun issiqlik qabul qiluvchi – o'rab turuvchi muhit bo'lsa, issiqlik nasoslari uchun o'rab turuvchi muhit issiqlik berish manbasi hisoblanadi.

Shuning uchun issiqlik nasoslari sikllari sovitgichlarnikidan farq qilmaydi.

# issiqlik nasosining ish jarayoni

## isitish jarayoni

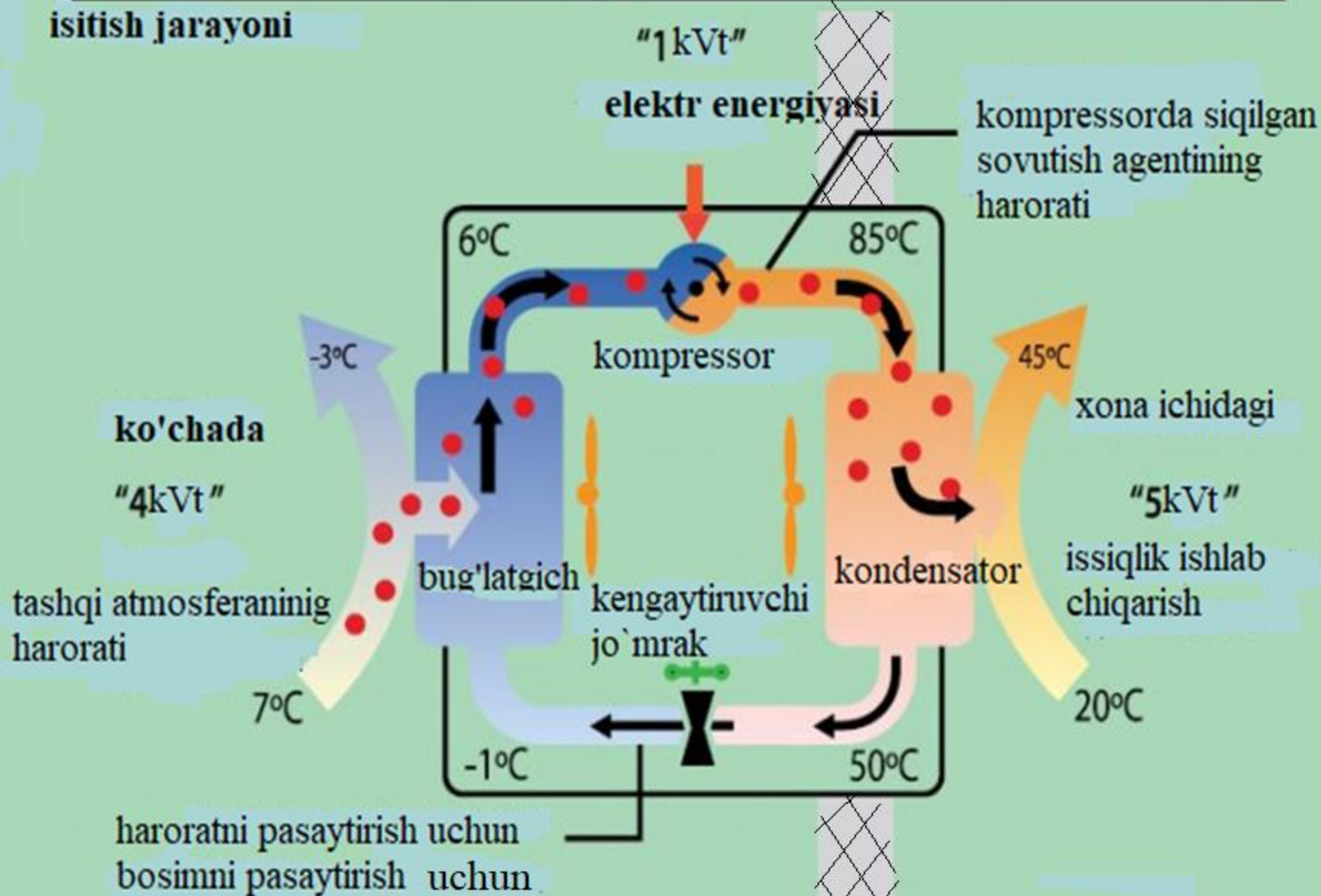

## **Nazorat savollari va topshiriqlar**

1. Sovutish qurilmalari va issiqlik nasoslari aniqlanishlarini keltiring. Ularning umumiy va farq qiluvchi xususiyatlarini keltiring.
2. Kompresion sovutkich qurilmasi printsiptial sxemasini tasvirlang va uni Ts – diagrammasida tahlil qiling.
3. Absorbtsion sovutkich kurilmasi sxemasini tasvirlang va uni kompresion sovutkich mashinalari bilan solishtirib, afzalliklari va kamchiliklarini ko'rsating.
4. Issiqlik nasosining qo'llanilish sohalarini gapirib bering va farq qiluvchi xususiyatlarini ko'rsating. Issiqlik nasosi sxemasini keltiring.
5. Sovutkich qurilmasi va issiqlik nasosi uchun issiqlikdan qayta foydalanish koeffitsientini ifodalang. Ularni solishtirib, tahlil qiling.

***E`TIBORINGIZ UCHUN  
RAHMAT***