

LECTURE NOTES ON THERMODYNAMICS

Joseph M. Powers

Department of Aerospace and Mechanical Engineering
University of Notre Dame
Notre Dame, Indiana 46556-5637
USA

updated
04 March 2022, 4:36pm

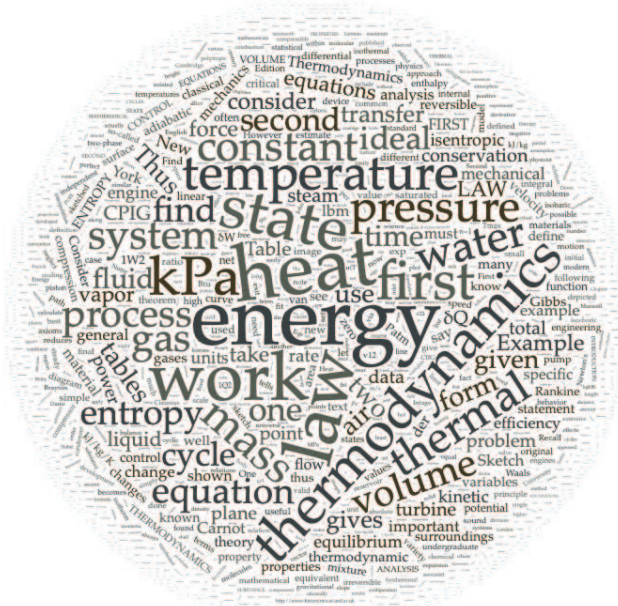

Contents

| | |
|--|-----------|
| Preface | 9 |
| 1 Introduction | 11 |
| 1.1 Some semantics | 11 |
| 1.2 Historical milestones | 14 |
| 1.3 Philosophy of science note | 16 |
| 1.4 Some practical applications | 17 |
| 1.5 Example to illustrate homework solution style | 24 |
| 1.6 Thermodynamic system and control volume | 29 |
| 1.7 Macroscopic versus microscopic | 30 |
| 1.8 Properties and state of a substance | 33 |
| 1.9 Processes and cycles | 34 |
| 1.10 Fundamental variables and units | 35 |
| 1.11 Zeroth law of thermodynamics | 36 |
| 1.12 Secondary variables and units | 37 |
| 2 Properties of a pure substance | 43 |
| 2.1 The pure substance | 43 |
| 2.2 Vapor-liquid-solid phase equilibrium | 43 |
| 2.3 Independent properties | 48 |
| 2.4 Thermal equations of state | 49 |
| 2.4.1 Ideal gas law | 50 |
| 2.4.2 Non-ideal thermal equations of state | 62 |
| 2.4.2.1 van der Waals | 62 |
| 2.4.2.2 Redlich-Kwong | 63 |
| 2.4.3 Compressibility factor | 63 |
| 2.4.4 Tabular thermal equations of state | 65 |
| 2.4.4.1 Saturated liquid-vapor water, temperature tables | 66 |
| 2.4.4.2 Saturated liquid-vapor water, pressure tables | 68 |
| 2.4.4.3 Superheated water tables | 71 |
| 2.4.4.4 Compressed liquid water tables | 71 |
| 2.4.4.5 Saturated water, solid-vapor | 71 |

| | | |
|-----------|--|------------|
| 2.4.4.6 | Tables for other materials | 73 |
| 2.4.4.7 | Linear interpolation of tabular data | 73 |
| 2.4.4.7.1 | Single interpolation | 74 |
| 2.4.4.7.2 | Double interpolation | 76 |
| 3 | The first law of thermodynamics | 81 |
| 3.1 | Mathematical preliminaries: exact differentials | 81 |
| 3.1.1 | Partial derivatives | 82 |
| 3.1.2 | Total derivative | 82 |
| 3.2 | Work | 91 |
| 3.2.1 | Definitions | 91 |
| 3.2.2 | Work for a simple compressible substance | 92 |
| 3.2.3 | Other forms of work | 107 |
| 3.3 | Heat | 108 |
| 3.4 | Representations of the first law | 111 |
| 3.4.1 | Cycle | 111 |
| 3.4.2 | Process | 115 |
| 3.5 | Specific internal energy for general materials | 121 |
| 3.6 | Specific enthalpy for general materials | 122 |
| 3.7 | Specific heat capacity | 123 |
| 3.8 | Caloric equations of state | 126 |
| 3.8.1 | Ideal gases | 126 |
| 3.8.1.1 | Calorically perfect | 127 |
| 3.8.1.2 | Calorically imperfect | 130 |
| 3.8.2 | Liquids and solids | 138 |
| 3.8.3 | General materials | 141 |
| 3.9 | Time-dependency | 144 |
| 3.10 | Final comments on conservation | 154 |
| 4 | First law analysis for a control volume | 157 |
| 4.1 | Detailed derivations of control volume equations | 158 |
| 4.1.1 | Relevant mathematics | 159 |
| 4.1.1.1 | Fundamental theorem of calculus | 159 |
| 4.1.1.2 | Divergence theorem | 159 |
| 4.1.1.3 | Leibniz's rule | 161 |
| 4.1.1.4 | General transport theorem | 166 |
| 4.1.1.5 | Reynolds transport theorem | 166 |
| 4.1.1.6 | Fixed (control) volumes | 167 |
| 4.1.2 | Conservation axioms | 168 |
| 4.1.2.1 | Mass | 169 |
| 4.1.2.2 | Energy | 179 |
| 4.1.2.2.1 | Total energy term | 180 |

| | | |
|-----------|---|------------|
| 4.1.2.2.2 | Work term | 180 |
| 4.1.2.2.3 | Heat transfer term | 181 |
| 4.1.2.2.4 | The first law of thermodynamics | 181 |
| 4.2 | Mass conservation in brief | 186 |
| 4.3 | Energy conservation in brief | 187 |
| 4.4 | Some devices | 191 |
| 4.4.1 | Throttling device | 192 |
| 4.4.2 | Nozzles and diffusers | 196 |
| 4.4.3 | Turbine | 197 |
| 4.4.4 | Pumps and compressors | 198 |
| 4.4.5 | Heat exchanger | 199 |
| 4.5 | Introduction to the Rankine cycle | 203 |
| 4.6 | Preview: equations of continuum mechanics | 210 |
| 4.6.1 | Full set | 210 |
| 4.6.2 | Static solids equations | 211 |
| 4.6.3 | Incompressible fluid mechanics equations | 211 |
| 4.6.4 | Compressible fluid mechanics equations | 212 |
| 4.6.5 | Heat transfer in incompressible static solids | 212 |
| 5 | The second law of thermodynamics | 213 |
| 5.1 | Statements of the second law | 214 |
| 5.1.1 | Entropy-based statement | 215 |
| 5.1.2 | Clausius statement | 216 |
| 5.1.3 | Kelvin-Planck statement | 216 |
| 5.1.4 | Carathéodory statement | 217 |
| 5.1.5 | Judeo-Christian statement | 219 |
| 5.1.6 | Historian-inspired statement | 219 |
| 5.1.7 | Literature-inspired statement | 219 |
| 5.1.8 | Food service-inspired statement | 220 |
| 5.2 | Reversible and irreversible processes | 220 |
| 5.3 | Analysis of Carnot heat engines | 221 |
| 5.4 | The absolute temperature scale | 225 |
| 5.5 | Analysis of Carnot refrigerators and heat pumps | 226 |
| 5.6 | Rejected thermal energy on a national scale | 229 |
| 6 | Entropy | 233 |
| 6.1 | Theoretical development | 233 |
| 6.2 | Second law in terms of entropy | 239 |
| 6.3 | The Gibbs equation | 246 |
| 6.4 | Entropy for ideal gases | 249 |
| 6.4.1 | Calorically perfect | 249 |
| 6.4.2 | Calorically imperfect | 251 |

| | | |
|----------|---|------------|
| 6.5 | Entropy for an incompressible solid or liquid | 254 |
| 6.6 | Iso- curves | 255 |
| 6.6.1 | Isochores | 255 |
| 6.6.2 | Isobars | 255 |
| 6.6.3 | Isentropes | 256 |
| 6.7 | Isentropic relations for an ideal gas | 257 |
| 6.7.1 | Calorically perfect | 257 |
| 6.7.2 | Calorically imperfect | 271 |
| 6.8 | Two cycles | 273 |
| 6.8.1 | Carnot | 273 |
| 6.8.2 | Otto | 282 |
| 6.9 | Entropy of thermo-mechanical mixing | 287 |
| 6.10 | Probabilistic approach to entropy | 294 |
| 6.11 | Summary statement of thermodynamics | 306 |
| 7 | Second law analysis for a control volume | 309 |
| 7.1 | Irreversible entropy production | 309 |
| 7.2 | Bernoulli principle | 315 |
| 7.2.1 | Incompressible limit | 317 |
| 7.2.2 | Calorically perfect ideal gas limit | 318 |
| 7.2.3 | Torricelli's formula | 319 |
| 7.3 | Component efficiency | 324 |
| 8 | Cycles | 327 |
| 8.1 | Rankine | 327 |
| 8.2 | Brayton | 336 |
| 8.3 | Refrigeration | 350 |
| 9 | Mathematical foundations | 355 |
| 9.1 | Maxwell relations | 355 |
| 9.2 | Functions of two independent variables | 357 |
| 9.3 | Legendre transformations | 358 |
| 9.4 | Specific heat capacity | 364 |
| 9.5 | The first law and coordinate transformations | 367 |
| 9.6 | The van der Waals gas | 369 |
| 9.7 | Adiabatic sound speed | 378 |
| 9.8 | Introduction to compressible flow | 385 |
| 9.8.1 | Acoustics | 386 |
| 9.8.2 | Compressible Bernoulli principle | 390 |
| 9.8.3 | Steady flow with area change | 393 |
| | Appendix | 397 |

Bibliography

413

Index

421

Preface

These are lecture notes for AME 20231, Thermodynamics, a sophomore-level undergraduate course taught in the Department of Aerospace and Mechanical Engineering at the University of Notre Dame. The objective of the course is to survey practical and theoretical problems in classical thermodynamics. The emphasis is on the axiomatic approach to equilibrium thermodynamics and its application to practical devices. However, there are some brief appeals to the non-equilibrium and molecular underpinnings of thermodynamics.

The notes draw often on the text specified for the course, Borgnakke and Sonntag's (BS) *Fundamentals of Thermodynamics*, Ninth Edition, John Wiley, Hoboken, NJ, 2017, especially Chapters 1-7, 9, 10, 12, and 15. In general the nomenclature of BS is used, and much of the notes follow a similar structure as the text. Some example problems have been directly taken from BS and other texts; specific citations are given where appropriate.

These notes emphasize problem-solving and rigorous development of the underlying classical theory; the student should call on other reference materials to fill some of the gaps. It should also be remembered that practice is essential to the learning process; the student would do well to apply the techniques presented here by working many problems.

An unusual aspect of the notes is the inclusion of accompanying text and figures related to the history of classical thermodynamics. Where possible, citations of original work are provided; most citations are linked directly to the original source material via click-able text. Additionally, an extensive annotated bibliography is provided. This is an attempt to fill gaps in most modern undergraduate texts, which at best provide small guidance to original thermodynamics scholarship.

The notes and course data can be found at <https://www3.nd.edu/~powers/ame.20231>. At this stage, anyone is free to make copies for their own use. I would be happy to hear about suggestions for improvement. Thanks to many of the students, past and present, whose diligence in identifying dozens of errors has been useful.

Joseph M. Powers

powers@nd.edu

<https://www3.nd.edu/~powers>

Notre Dame, Indiana; USA

 04 March 2022

The content of this book is licensed under Creative Commons Attribution-Noncommercial-No Derivative Works 3.0.

Chapter 1

Introduction

Read *BS*, Chapter 1

1.1 Some semantics

We introduce here *classical thermodynamics*. The word “thermo-dynamic,” used first by Thomson (later Lord Kelvin),¹ has Greek origin, and is translated² as the combination of

- $\theta\acute{\epsilon}\rho\mu\eta$, *therme*: heat, and
- $\delta\acute{\upsilon}\nu\alpha\mu\iota\varsigma$, *dynamis*: power.

An image of Thomson and his 1849 first use of the word is given in Fig. 1.1.



12. A *perfect* thermo-dynamic engine of any kind, is a machine by means of which the greatest possible amount of mechanical effect can be obtained from a given thermal agency; and, therefore, if in any manner we can construct or imagine a perfect engine which may be applied for the transference of a given quantity of heat from a body at any given temperature, to another body, at a lower given temperature, and if we can evaluate the mechanical effect thus obtained, we shall be able to answer the question at present under consideration, and so to complete the theory of the motive power of heat.

Figure 1.1: William Thomson (Lord Kelvin) (1824-1907), Ulster-born Scottish scientist; image from <http://mathshistory.st-andrews.ac.uk/Biographies/Thomson.html> and image giving the first use of “thermo-dynamic” extracted from his 1849 work.

The modifier “classical” is used to connote a description in which quantum mechanical effects, the molecular nature of matter, and the statistical nature of molecular behavior

¹W. Thomson (later Kelvin), 1849, “An account of Carnot’s theory of the motive power of heat; with numerical results deduced from Regnault’s experiments on steam,” *Transactions of the Royal Society of Edinburgh*, 16:541-574. See also C. W. Smith, 1977, “William Thomson and the creation of thermodynamics: 1840-1855,” *Archive for History of Exact Sciences*, 16(3): 231-288.

²All Greek spellings and etymologies are drawn from the *Oxford English Dictionary*, 2nd edition, 1989.

are not considered in any detail. These effects will not be completely ignored; however, they will be lumped into simple averaged models that are valid on the macroscale. As an example, for ordinary gases, our classical thermodynamics will be valid for systems whose characteristic length scale is larger than the mean free path between molecular collisions. For air at atmospheric density, this about $0.1 \mu\text{m} = 10^{-7} \text{ m}$).

Additionally, “classical” also connotes a description in which the effects of finite time-dependency are ignored. In this sense, thermodynamics resembles the field of statics from Newtonian mechanics. Recall Newton’s second law of motion, $m d^2\mathbf{x}/dt^2 = \sum \mathbf{F}$, where m is the mass, \mathbf{x} is the position vector, t is time, and \mathbf{F} is the force vector. In the statics limit where $\sum \mathbf{F} = \mathbf{0}$, inertial effects are ignored, as is time-dependency. Now, a Newtonian would consider dynamics to imply motion, and so would consider thermodynamics to imply the time-dependent motion of heat. So a Newtonian would be more inclined to call the subject of these notes “thermostatics.” However, if we return to the earlier Greek translation of dynamics as power, we are actually truer to the classical connotation of thermodynamics. For the fundamental interplay of thermodynamics is that between so-called thermal energy (as might be thought of when considering heat) and mechanical energy (as might be thought of when considering power, a work rate). More formally, we will take the definition

- THERMODYNAMICS: the science that deals with heat and work and those properties of matter that relate to heat and work.

One of the main goals of these notes will be to formalize the relationship between heat, work, and energy.

We close this section by noting that the concept of energy has evolved through time, but has ancient origins. The word itself had its first recorded use by Aristotle.³ His portrait, along with an image of the relevant section of an 1818 translation of his treatise, is depicted in Figs. 1.2. In the Greek, the word $\acute{\epsilon}\nu\acute{\epsilon}\rho\gamma\epsilon\iota\alpha$, “energeia,” connotes activity or operation. While the word was known to Aristotle, its modern usage was not; it was the English polymath Thomas Young who first used the word “energy,” consistent with any sort of modern usage, in this case kinetic energy.⁴ A portrait of Young and an image of his text defining energy, in actuality kinetic energy, in modern terms are shown in Fig. 1.3.

³Aristotle, ~335 BC, *The Rhetoric, Poetic, and Nicomachean Ethics*, Book III, Ch. XI, English translation by T. Taylor, 1818, Black, London, see pp. 242-243.

⁴T. Young, 1807, *Lectures on Natural Philosophy*, William Savage, London, p. 52.

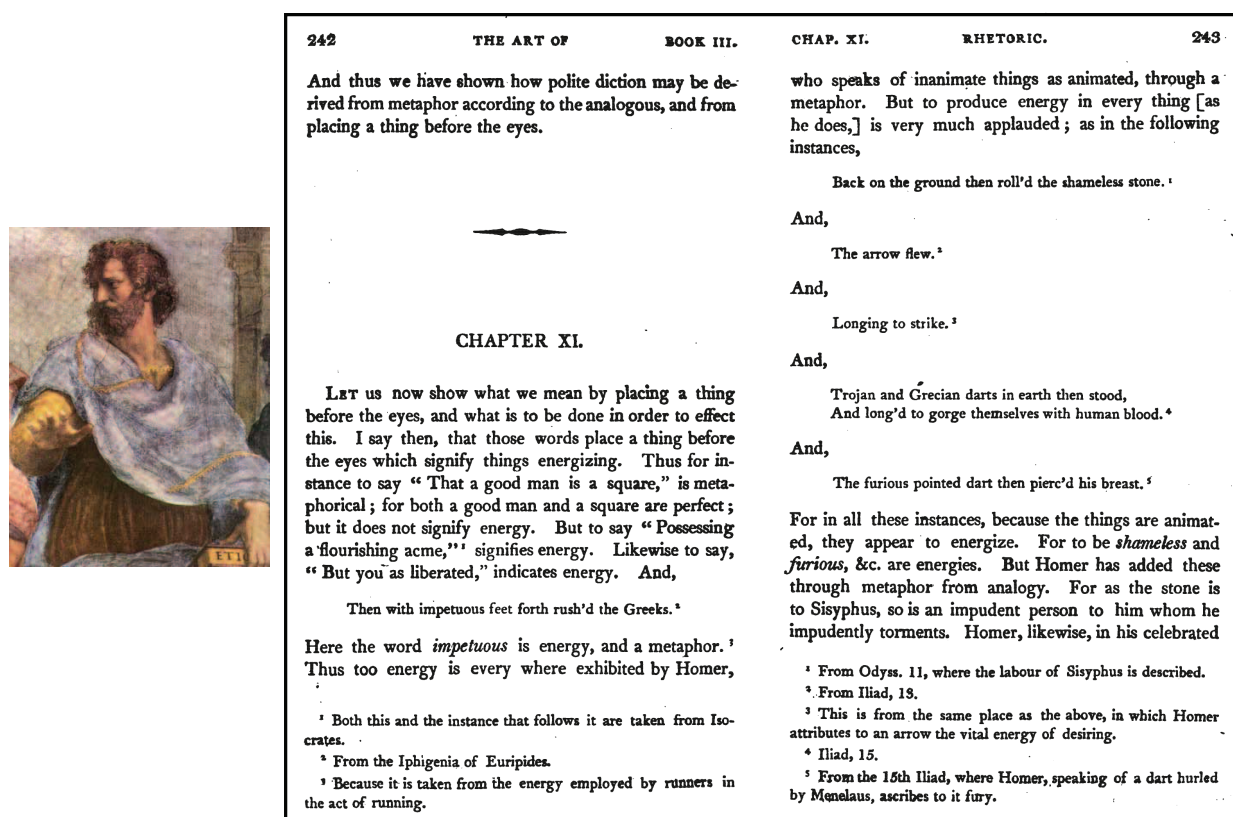

Figure 1.2: Aristotle (384 BC-322 BC), Greek philosopher who gives the first recorded use of the word "energy" and whose method of logic permeates classical thermodynamics; image from <http://mathshistory.st-andrews.ac.uk/Biographies/Aristotle.html> and an image of Aristotle's usage of the word "energy" from his *Nicomachean Ethics*.

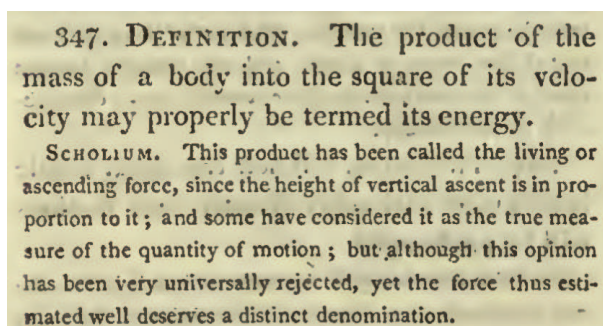

Figure 1.3: Thomas Young (1773-1829), English natural philosopher; image from [https://en.wikipedia.org/wiki/Thomas_Young_\(scientist\)](https://en.wikipedia.org/wiki/Thomas_Young_(scientist)), and a reproduction of his more modern 1807 definition of (kinetic) energy.

Finally, though she did not use the word “energy,” the notion of what is now known as kinetic energy being related to the square of velocity was first advanced by du Châtelet,⁵ pictured in Fig. 1.4.



Figure 1.4: Gabrielle Émilie Le Tonnelier de Breteuil, marquise du Châtelet (1706-1749), French physicist; image from https://en.wikipedia.org/wiki/Emilie_du_Chatelet.

1.2 Historical milestones

Thermodynamics has a long history; unfortunately, it was not blessed with the crispness of development that mechanics realized with Newton. In fact, its growth is filled with false steps, errors, and debate that continues to this day. Truesdell⁶ and Müller^{7,8} summarize the development in their idiosyncratic histories. Some of the milestones of its development are given here:

- first century AD: Hero of Alexandria documents many early thermal engines.
- 1593: Galileo develops a water thermometer.
- 1650: Otto von Guericke designs and builds the first vacuum pump.
- 1662: Robert Boyle develops his law for isothermal ideal gases.

⁵É. du Châtelet, 1740, *Institutions de Physique*, Chez Prault, Paris.

⁶C. Truesdell, 1980, *The Tragicomical History of Thermodynamics, 1822-1854*, Springer, New York.

⁷I. Müller, 2007, *A History of Thermodynamics: the Doctrine of Energy and Entropy*, Springer, Berlin.

⁸I. Müller and W. H. Müller, 2009, *Fundamentals of Thermodynamics and Applications with Historical Annotations and Many Citations from Avogadro to Zermelo*, Springer, Berlin.

- 1679: Denis Papin develops his steam digester, forerunner to the steam engine.
- 1687: Isaac Newton publishes *Philosophiæ Naturalis Principia Mathematica*.
- 1698: Thomas Savery patents an early steam engine.
- 1710: Thomas Newcomen creates a more practical steam engine.
- 1760s: Joseph Black develops calorimetry.
- 1780s: James Watt improves the steam engine.
- 1798: Benjamin Thompson (Count Rumford) considers the mechanical equivalent of heat from cannon boring experiments.
- 1824: Nicolas Léonard Sadi Carnot discusses idealized heat engines.
- 1840: Germain Henri Hess considers an early version of the first law of thermodynamics for work-free chemical reactions.
- 1840s: Julius Robert von Mayer relates heat and work.
- 1840s: James Prescott Joule relates heat and work.
- 1847: Hermann von Helmholtz publishes his theory of energy conservation.
- 1848: William Thomson (Lord Kelvin) postulates an absolute zero of temperature.
- 1850: Rudolf Julius Emanuel Clausius formalizes the second law of thermodynamics.
- 1865: Clausius introduces the concept of entropy.
- 1871: James Clerk Maxwell develops the Maxwell relations.
- 1870s: Josiah Willard Gibbs further formalizes mathematical thermodynamics.
- 1870s: Maxwell and Ludwig Boltzmann develop statistical thermodynamics.
- 1889: Gibbs develops statistical mechanics, giving underlying foundations for classical and statistical thermodynamics.
- 1909: Constantin Carathéodory publishes a rigorous axiomatic formulation of the laws of thermodynamics.
- 1931: Lars Onsager advances non-equilibrium thermodynamics with his reciprocity relations.

Much development of the twentieth century was recognized by the Nobel prize, including that of Nobel laureates

- Jacobus Henricus van't Hoff (1901),
- Johannes van der Waals (1910),
- Heike Kamerlingh Onnes (1913),
- Max Planck (1918),
- Walther Nernst (1920),
- Albert Einstein (1921),
- Erwin Schrödinger (1933),
- Enrico Fermi (1938),
- Percy Bridgman (1946),
- William Giaouque (1949),
- Lars Onsager (1968),
- Ilya Prigogine (1977), and
- Kenneth Wilson (1982).

Strictly speaking, Newton did not consider the subject matter of thermodynamics. However, much of his work is concerned with energy. His theories are appropriate only for mechanical energy. The notion that thermal energy existed and that it could be equivalent to mechanical energy was not part of Newtonian mechanics. However, temperature was known to Newton, as was Boyle's law. When he tried to apply his theories to problems of thermodynamics, such as calculation of the speed of sound in air, they notably failed. This will be discussed at the conclusion of these notes in Ch. 9.7. The reason for the failure required consideration of the yet-to-be-developed second law of thermodynamics.

1.3 Philosophy of science note

As with science in general, thermodynamics is based on *empirical observation*. Moreover, it is important that those observations be repeatable. A few postulates, also known as *axioms*, will serve as the foundation of our science. Following Occam's razor,⁹ we shall seek as few axioms as possible to describe this behavior. We will supplement these axioms with some necessary definitions to describe nature. Then we shall use our reason to deduce from the axioms and definitions certain theorems of engineering relevance.

This approach, that has its foundations in Aristotelian methods, is not unlike the approach taken by Euclid to geometry, Aquinas to theology, or Newton to mechanics. A



Figure 1.5: Euclid of Alexandria (~ 325 BC- ~ 265 BC), Greek mathematician whose rational exposition of geometry formed a model for how to present classical thermodynamics; image from <http://mathshistory.st-andrews.ac.uk/Biographies/Euclid.html>.

depiction of Euclid is given in Fig. 1.5. Consider for example that Euclid defined certain entities such as points, lines, and planes, then adopted certain axioms such as parallel lines do not meet at infinity, and went on to prove a variety of theorems. Classical thermodynamics follows the same approach. Concepts such as system and process are defined, and axioms, known as the laws of thermodynamics, are proposed in such a way that the minimum amount of theory is able to explain the maximum amount of data.

Now, in some sense science can never be formally proved; it can only be disproved. We retain our axioms as long as they are useful. When faced with empirical facts that unambiguously contradict our axioms, we are required to throw away our axioms and develop new ones. For example, in physics, the Michelson-Morley experiment forced Einstein to abandon the axioms of Euclid, Newton, and Clausius for his theory of general relativity. It turns out that we can still use these axioms, as long as we are considering problems in which the speed of our reference frame is far less than the speed of light. In an example from biology that is the topic of a popular science book,¹⁰ it was noted that it was once believed that all swans were white. This working hypothesis was perfectly acceptable until 1697, when a black swan was discovered in Australia. Thus, the “theory” (though it is not a highly profound theory) that all swans were white was unambiguously discredited. It will be briefly seen in Ch. 6.10 that non-classical thermodynamics actually has a deep relation to probability and statistics and information, a topic that transcends thermodynamics.

1.4 Some practical applications

It turns out that the classical approach to thermodynamics has had success in guiding the engineering of devices. People have been building mechanical devices based on thermal

⁹from William of Occam, (c. 1288-c. 1348) English Franciscan friar and philosopher.

¹⁰N. N. Taleb, 2007, *The Black Swan: The Impact of the Highly Improbable*, Random House, New York.

energy inputs for centuries, without the benefit of a cleanly enunciated theory. Famously, Hero of Alexandria, perhaps the first recognized thermal engineer, documented a variety of devices. These include an early steam engine¹¹ known as the *æolipile*, pumps, and a device to use fire to open doors. Hero and a nineteenth century rendition of his steam engine are shown in Fig. 1.6. While Hero's contributions are a matter of some speculation inspired by

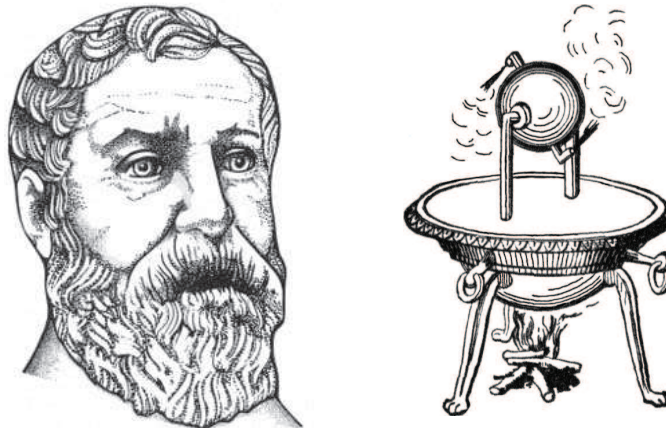

Figure 1.6: Hero of Alexandria (10-70 AD), Greek engineer and mathematician who devised some early ways to convert thermal energy into mechanical energy, and his *æolipile*; images from https://en.wikipedia.org/wiki/Hero_of_Alexandria.

ancient artistry, the much later works of Denis Papin (1647-1712) are more certain. Papin invented the so-called steam digester, that anticipated both the pressure cooker and the steam engine. The device used steam power to lift a weight. Depictions of Papin and his device are found in Fig. 1.7. Significant improvements were led by James Watt (1736-1819) of Scotland. An image of Watt and one of his engines is shown in Fig. 1.8.

¹¹P. Keyser, 1990, "A new look at Heron's steam engine," *Archive for History of Exact Sciences*, 44(2): 107-124.

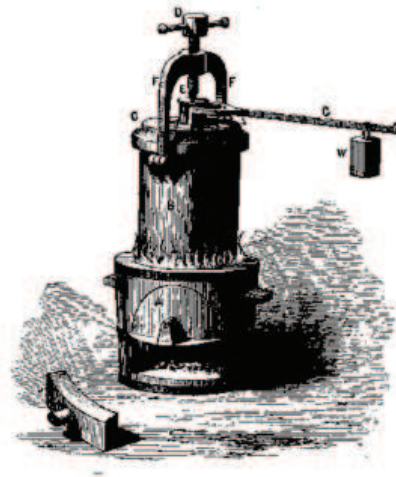
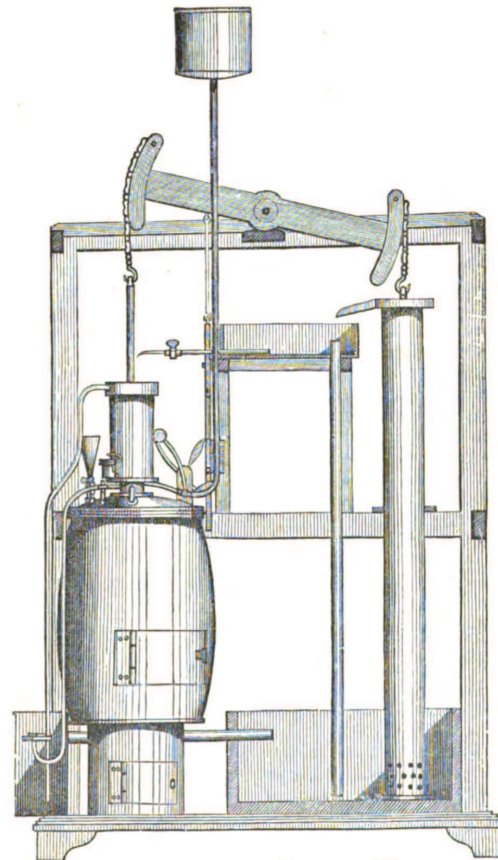

Figure 1.7: French-born inventor Denis Papin (1647-1712) and his steam digester; images from https://en.wikipedia.org/wiki/Denis_Papin.



a)



* Fig. IV.—Watt's model in Glasgow College.

b)

Figure 1.8: a) Scottish engineer James Watt (1736-1819); image from https://en.wikipedia.org/wiki/James_Watt, b) Sketch of one of Watt's steam engines; image from W. J. M. Rankine, 1859, *A Manual of the Steam Engine and Other Prime Movers*, First Edition, Griffin, London.

These engines were adopted for transportation. In 1807, the American engineer Robert Fulton (1765-1815) was the first to use steam power in a commercial nautical vessel, the *Clermont*, that was powered by a Boulton and Watt steam engine. Soon after, in 1811 in Scotland, the first European commercial steam vessel, the *Comet*, embarked. We have a sketch of the *Comet* and its steam power plant in Fig. 1.9. On land, steam power soon

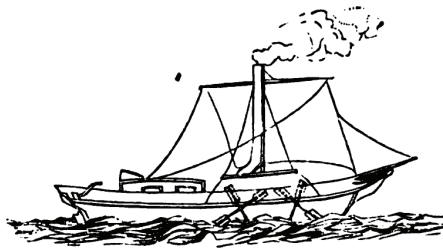

Fig. VI.—The “Comet,” 1811-12.

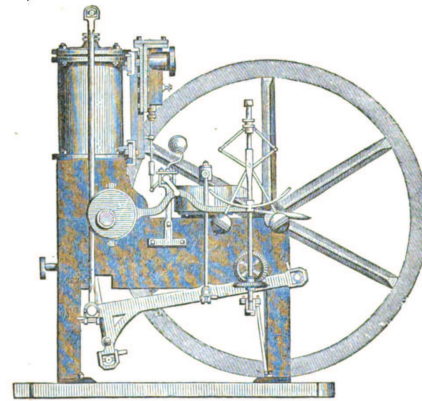

Fig. VII.—Engine of the “Comet,” 1811-12.

Figure 1.9: Sketch of the *Comet* and its steam engine; image from W. J. M. Rankine, 1859, *A Manual of the Steam Engine and Other Prime Movers*, First Edition, Griffin, London.

enabled efficient rail transportation. A famous early steam locomotive was the English engineer Robert Stephenson’s (1803-1859) *Rocket*, sketched in Fig. 1.10.

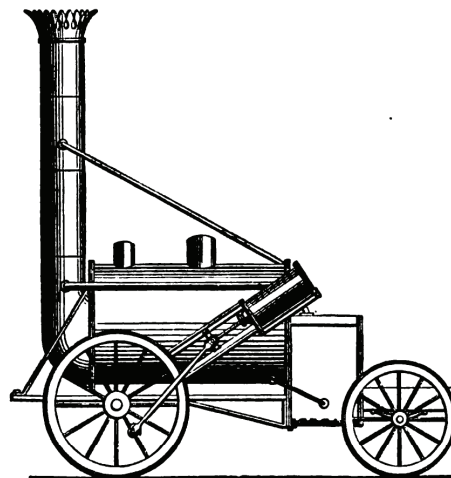

Fig. VIII.—The “Rocket,” 1829.

Figure 1.10: Sketch of the *Rocket*; image from W. J. M. Rankine, 1859, *A Manual of the Steam Engine and Other Prime Movers*, First Edition, Griffin, London.

The effect of steam power, a contribution driven by engineers, on the development of the world remains remarkable. It is what is commonly known as a *disruptive technology* as its widespread adoption displaced other well-established technologies. While it is difficult to quantify historical pronouncements, it is likely that the effect on the world was even more profound than the introduction of networked computers in the late twentieth century. In short, steam power was the linchpin for the industrial revolution. Steam power replaced animal power as a prime mover throughout much of the world and, where implemented, enabled rapid development of broad economic segments: mining, manufacturing, land and sea transportation, among others. Large scale population movements ensued as opportunities in urban manufacturing centers made industrial work more appealing than agricultural work. Certainly, changes precipitated by the advent of steam power were contributing factors in widespread social unrest in the nineteenth century, ranging from labor strife to war between nation states.

Some more modern devices, listed here, are relevant to thermodynamics:

- simple steam power plant,
- fuel cells,
- vapor-compression refrigeration cycle,
- air separation plant,
- the gas turbine, and
- the chemical rocket engine.

As an example, the main power plant of the University of Notre Dame, depicted in Fig. 1.11, is based on a steam power cycle that will be a topic of study in this course. Additionally, one might consider the following topics to have thermodynamic relevance:

- gasoline and Diesel engines,
- the weather,
- cooking,
- heating, ventilation, air conditioning, and refrigeration (HVAC&R), or
- materials processing (metals, polymers, etc.).

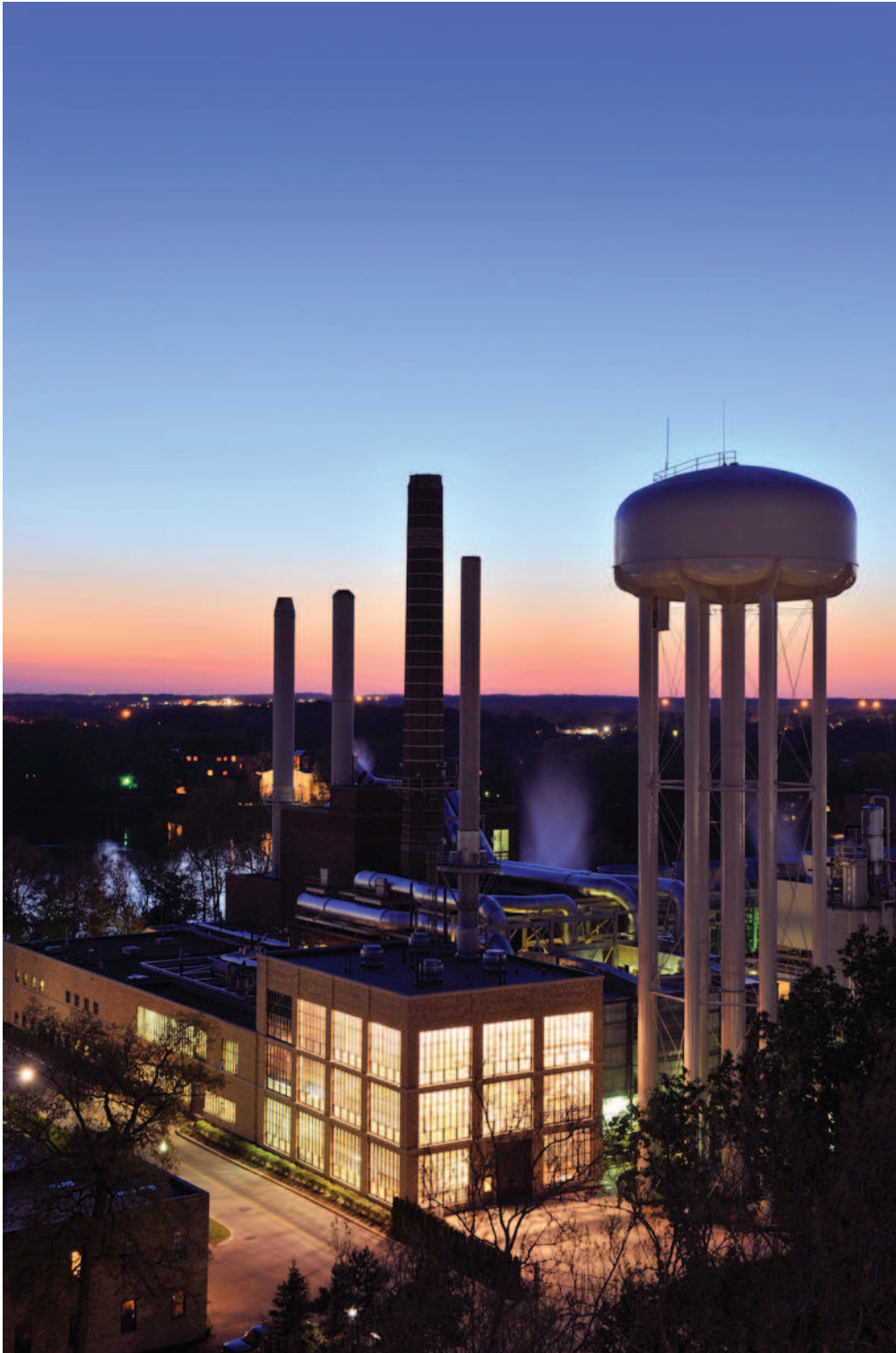

Figure 1.11: University of Notre Dame Power Plant; image from Matt Cashore, University of Notre Dame.

1.5 Example to illustrate homework solution style

Proper technical communication is important for engineering. Here is an example of how one might construct a homework solution. We take an example involving mechanical energy from introductory physics:

Example 1.1

A mass of $m = 1$ kg is initially at rest and is dropped from a height of $y = y_o = 10$ m above the ground, where gravitational acceleration $g = 9.81$ m/s². Neglect drag forces. Find the time to reach the ground, the kinetic energy as a function of time, and the potential energy as a function of time. Plot key results.

The scenario is sketched in Fig. 1.12. The principle governing the motion of the body is Newton's

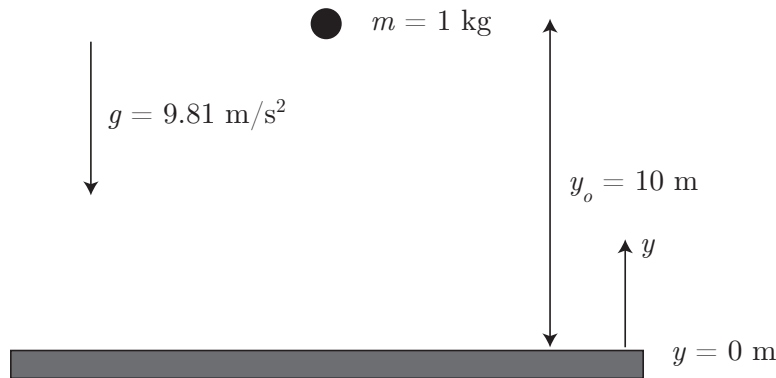

Figure 1.12: Sketch of problem for particle motion in a gravitational field.

second law, embodied in a second order differential equation. The only force is the gravitational force acting in the negative y direction. This gives the equation

$$m \frac{d^2 y}{dt^2} = -mg. \quad (1.1)$$

Note the mass m cancels here, giving

$$\frac{d^2 y}{dt^2} = -g. \quad (1.2)$$

Integrate once to get

$$\frac{dy}{dt} = -gt + C_1, \quad (1.3)$$

where C_1 is a constant. Integrate a second time to get

$$y(t) = -\frac{1}{2}gt^2 + C_1 t + C_2. \quad (1.4)$$

We need two initial conditions for this second order ordinary differential equation. At time $t = 0$, we know from the problem statement that

$$y(0) = y_o, \quad \frac{dy}{dt}(0) = 0. \quad (1.5)$$

Applying the first initial condition, we get

$$y_o = -\frac{1}{2}g(0)^2 + C_1(0) + C_2 = C_2. \quad (1.6)$$

Thus, we have

$$y(t) = -\frac{1}{2}gt^2 + C_1t + y_o. \quad (1.7)$$

Apply the second initial condition to get

$$0 = -g(0) + C_1 = C_1. \quad (1.8)$$

Thus, we have

$$y(t) = -\frac{1}{2}gt^2 + y_o. \quad (1.9)$$

For the velocity, we get

$$\frac{dy}{dt} = -gt. \quad (1.10)$$

When the mass reaches the ground, $y = 0$. Solving for the time when $y = 0$, we get

$$0 = -\frac{1}{2}gt^2 + y_o, \quad (1.11)$$

$$\frac{1}{2}gt^2 = y_o, \quad (1.12)$$

$$t = \pm\sqrt{\frac{2y_o}{g}}. \quad (1.13)$$

We are considering t going forward, so we take the positive root, giving

$$t = \sqrt{\frac{2y_o}{g}}, \quad (1.14)$$

$$= \sqrt{\frac{2(10 \text{ m})}{9.81 \frac{\text{m}}{\text{s}^2}}}, \quad (1.15)$$

$$= \boxed{1.43 \text{ s}}. \quad (1.16)$$

The kinetic energy, KE , is

$$KE = \frac{1}{2}m\left(\frac{dy}{dt}\right)^2, \quad (1.17)$$

$$= \frac{1}{2}mg^2t^2. \quad (1.18)$$

The gravitational potential energy, PE , is

$$PE = mgy, \quad (1.19)$$

$$= mgy_o - \frac{1}{2}mg^2t^2. \quad (1.20)$$

Note that

$$KE + PE = mgy_o, \quad (1.21)$$

that is a constant. Thus, mechanical energy is conserved here! By conserved, we mean it does not change.

Numerically, we have for $y(t)$, $KE(t)$, and $PE(t)$,

$$y(t) = -\frac{1}{2} \left(9.81 \frac{\text{m}}{\text{s}^2} \right) t^2 + (10 \text{ m}), \quad (1.22)$$

$$= -\left(4.904 \frac{\text{m}}{\text{s}^2} \right) t^2 + (10 \text{ m}), \quad (1.23)$$

$$KE(t) = \frac{1}{2} (1 \text{ kg}) \left(-\left(9.81 \frac{\text{m}}{\text{s}^2} \right) t \right)^2, \quad (1.24)$$

$$= \left(48.12 \frac{\text{kg m}^2}{\text{s}^4} \right) t^2, \quad (1.25)$$

$$= \left(48.12 \frac{\text{kg m}^2}{\text{s}^4} \frac{\text{J}}{\text{kg m}^2/\text{s}^2} \right) t^2, \quad (1.26)$$

$$= \boxed{\left(48.12 \frac{\text{J}}{\text{s}^2} \right) t^2}, \quad (1.27)$$

$$PE(t) = (1 \text{ kg}) \left(9.81 \frac{\text{m}}{\text{s}^2} \right) (10 \text{ m}) - \frac{1}{2} (1 \text{ kg}) \left(9.81 \frac{\text{m}}{\text{s}^2} \right)^2 t^2, \quad (1.28)$$

$$= \boxed{(98.1 \text{ J}) - \left(48.12 \frac{\text{J}}{\text{s}^2} \right) t^2}. \quad (1.29)$$

The position as a function of time is plotted in Fig. 1.13. The kinetic, potential, and total mechanical

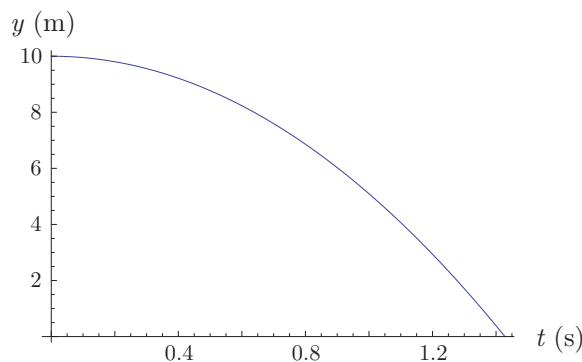

Figure 1.13: Position versus time for particle accelerating in a gravitational field with no drag force.

energies as functions of time are plotted in Fig. 1.14. One can tell by inspection that as potential energy decreases, kinetic energy increases just as much, rendering the total mechanical energy to be constant.

If we include drag forces, the total mechanical energy is not constant; in fact, it dissipates with time. We will omit the details, but if we include a simple drag force proportional to the particle velocity, we get the equations

$$m \frac{d^2 y}{dt^2} = -c \frac{dy}{dt} - mg, \quad y(0) = y_o, \quad \frac{dy}{dt}(t=0) = 0. \quad (1.30)$$

Skipping the details of calculation, if we take $c = 0.1 \text{ N s/m}$, and all other parameters as before, we

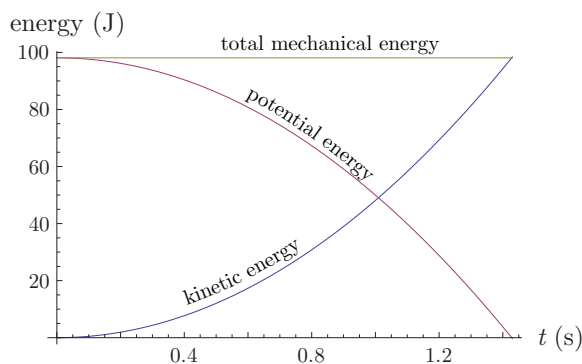

Figure 1.14: $KE(t)$, $PE(t)$ and total mechanical energy for a particle accelerating in a gravitational field with no drag force.

find

$$y(t) = (991 \text{ m}) - (981 \text{ m}) \exp\left(\frac{-t}{10 \text{ s}}\right) - \left(98.1 \frac{1}{\text{s}}\right) t, \quad (1.31)$$

$$KE(t) + PE(t) = (14533.5 \text{ J}) + (4811.8 \text{ J}) \exp\left(\frac{-t}{20 \text{ s}}\right) - (19247.2 \text{ J}) \exp\left(\frac{-t}{10 \text{ s}}\right) - \left(962.361 \frac{1}{\text{s}}\right) t. \quad (1.32)$$

The kinetic, potential, and total mechanical energies as functions of time are plotted in Fig. 1.15.

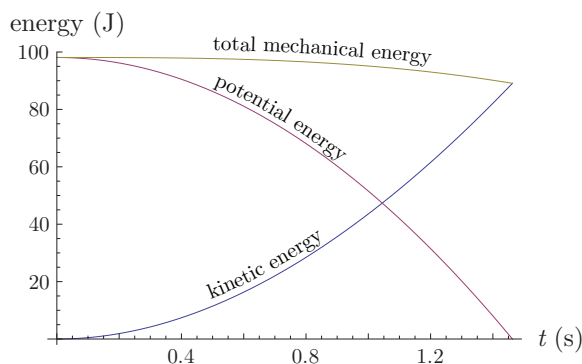

Figure 1.15: $KE(t)$, $PE(t)$ and total mechanical energy for a particle accelerating in a gravitational field in the presence of a drag force.

When drag forces are included, we begin with the same amount of total mechanical energy and potential energy. At the end of the calculation, we have the same amount of potential energy (zero), but less kinetic energy and less total mechanical energy. Where did this energy go? In fact, it is transformed into another form of energy, *thermal energy*, that is not accounted for in Newtonian mechanics. When we properly account for thermal energy, we will again impose a conservation of total energy, one of the main topics of this course, to be considered at the outset of Chapter 3.

We close this section with an image of Newton in Fig. 1.16, who began to study issues related to thermodynamics, and whose scientific methods imbue its development.



Figure 1.16: English genius Sir Isaac Newton (1643-1727), in a 1702 portrait by Sir Godfrey Kneller, whose classical mechanics broadly influenced the development of thermodynamics; image from https://commons.wikimedia.org/wiki/File:Sir_Isaac_Newton_by_Sir_Godfrey_Kneller,_Bt.jpg.

1.6 Thermodynamic system and control volume

We take the following definitions:

- THERMODYNAMIC SYSTEM: a quantity of fixed mass under investigation,
- SURROUNDINGS: everything external to the system,
- SYSTEM BOUNDARY: interface separating system and surroundings, and
- UNIVERSE: combination of system and surroundings.

The system, surroundings, and system boundary for a universe are shown for a potato-shaped system in Fig. 1.17. We allow two important interactions between the system and

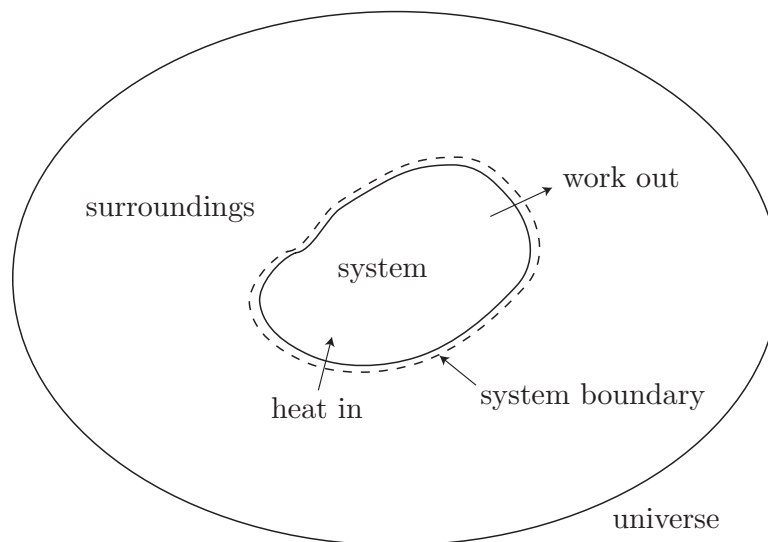

Figure 1.17: Sketch of a universe composed of a system, its surroundings, and the system boundary.

its surroundings:

- heat can cross into the system (our potato can get hot), and
- work can cross out of the system (our potato can expand).

Now, the system boundaries can change, for example the potato might expand on heating, but we can still distinguish the system and the surroundings. We now define an

- ISOLATED SYSTEM: a system that is not influenced by its surroundings.

Note that a potato with thick and inelastic skin will be isolated. We distinguish the system, that has constant mass, but possible variable volume, from the

- **CONTROL VOLUME:** fixed volume over which mass can pass in and out of its boundary.

The control volume is bounded by the

- **CONTROL SURFACE:** boundary of the control volume.

The mass within a control volume may or may not be constant. If there is fluid flow in and out there may or may not be accumulation of mass within the control volume. We will mainly study cases in which there is no accumulation, but this need not be the case. A sketch contrasting scenarios in which a fluid is compressed in which the system approach would be used against those where the control volume approach would be used is shown in Fig. 1.18. In summary,

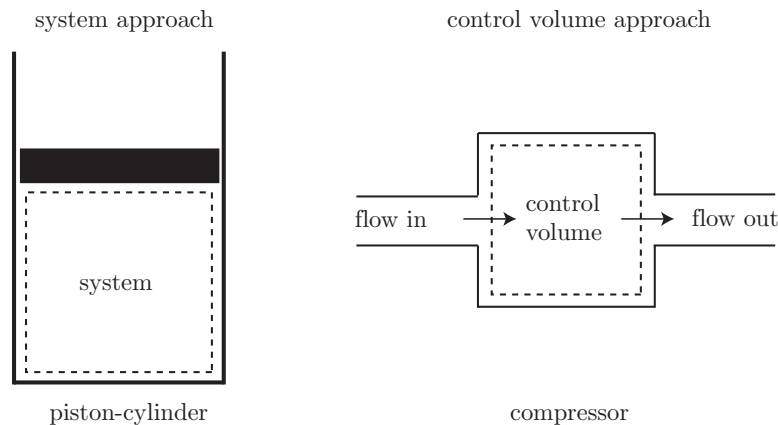

Figure 1.18: Comparison of system (fixed mass) and control volume (fixed volume) approaches in thermodynamics for two common scenarios: piston-cylinder compression (left) and compression in a flow device whose details are not shown (right).

- system \rightarrow fixed mass, closed, and
- control volume \rightarrow potentially variable mass, open.

1.7 Macroscopic versus microscopic

In principle, we could solve for the forces acting on every molecule and use Newton's laws to determine the behavior of systems. This is difficult for even modestly sized systems.

- If we had a volume of 1 m^3 of gas at atmospheric pressure and temperature, we would find that it was composed of 2.4×10^{25} molecules.
- We would need six equations of motion for each molecule, three for x, y, z , position, and three for u, v, w , velocity. This would require then a total of 1.4×10^{26} differential equations to solve simultaneously.

- Even with our largest computers, this is impossible today. Note most desktop computers only can store roughly 10^9 bytes of data in Random Access Memory (RAM).
- We can however model the average behavior of the molecules statistically.
- We can also use simple empirical relations that can be formally proved to capture the statistical nature of the flow. This will be our approach.
- classical thermodynamics will treat macroscopic effects only and ignore individual molecular effects. For example molecules bouncing off a wall exchange momentum with the wall and induce pressure. We could use Newtonian mechanics for each particle collision to calculate the net force on the wall. Instead our approach amounts to considering the *average* over space and time of the net effect of millions of collisions on a wall.

We will in fact assume that matter can be modeled as a

- CONTINUUM: the limit in which discrete changes from molecule to molecule can be ignored and distances and times over which we are concerned are much larger than those of the molecular scale. This will enable the use of calculus in our continuum thermodynamics.

The continuum theory can break down in important applications where the length and time scales are of comparable magnitude to molecular time scales. Important applications where the continuum assumption breaks down include

- rarefied gas dynamics of the outer atmosphere (relevant for low orbit space vehicles), and
- nano-scale heat transfer (relevant in cooling of computer chips).

To get some idea of the scales involved, we note that for air at atmospheric pressure and temperature that the time and distance between molecular collisions provide the limits of the continuum. Under these conditions, we find for air

- length $> 0.1 \mu\text{m}$, and
- time $> 0.1 \text{ ns}$,

will be sufficient to use the continuum assumption. For denser gases, these cutoff scales are smaller. For lighter gases, these cutoff scales are larger. Details of collision theory can be found in advanced texts such as that of Vincenti and Kruger.¹² They show for air that the mean free path λ is well modeled by the following equation:

$$\lambda = \frac{M}{\sqrt{2}\pi N \rho d^2}. \quad (1.33)$$

¹²W. G. Vincenti and C. H. Kruger, 1965, *Introduction to Physical Gas Dynamics*, John Wiley, New York, pp. 12-26.

Here, M is the molecular mass, \mathcal{N} is Avogadro's number, and d is the molecular diameter.

Example 1.2

Find the variation of mean free path with density for air.

We turn to Vincenti and Kruger for numerical parameter values, that are seen to be $M = 28.9 \text{ kg/kmole}$, $\mathcal{N} = 6.02252 \times 10^{23} \text{ molecule/mole}$, $d = 3.7 \times 10^{-10} \text{ m}$. Thus,

$$\lambda = \frac{\left(28.9 \frac{\text{kg}}{\text{kmole}}\right) \left(\frac{1 \text{ kmole}}{1000 \text{ mole}}\right)}{\sqrt{2}\pi \left(6.02252 \times 10^{23} \frac{\text{molecule}}{\text{mole}}\right) \rho \left(3.7 \times 10^{-10} \text{ m}\right)^2}, \quad (1.34)$$

$$= \frac{7.8895 \times 10^{-8} \frac{\text{kg}}{\text{molecule m}^2}}{\rho}. \quad (1.35)$$

Note that the unit ‘‘molecule’’ is not really a dimension, but really is literally a ‘‘unit,’’ that may well be thought of as dimensionless. Thus, we can safely say

$$\lambda = \boxed{\frac{7.8895 \times 10^{-8} \frac{\text{kg}}{\text{m}^2}}{\rho}}. \quad (1.36)$$

A plot of the variation of mean free path λ as a function of ρ is given in Fig. 1.19. Vincenti and Kruger

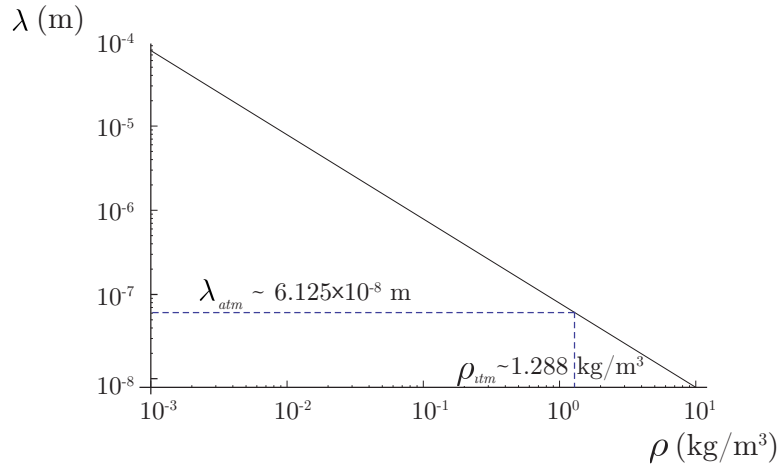

Figure 1.19: Mean free path length, λ , as a function of density, ρ , for air.

go on to consider an atmosphere with density of $\rho = 1.288 \text{ kg/m}^3$. For this density

$$\lambda = \frac{7.8895 \times 10^{-8} \frac{\text{kg}}{\text{m}^2}}{1.288 \frac{\text{kg}}{\text{m}^3}}, \quad (1.37)$$

$$= 6.125 \times 10^{-8} \text{ m}, \quad (1.38)$$

$$= 6.125 \times 10^{-2} \mu\text{m}. \quad (1.39)$$

Vincenti and Kruger also show the mean molecular speed under these conditions is roughly $c = 500 \text{ m/s}$, so the mean time between collisions, τ , is

$$\tau \sim \frac{\lambda}{c} = \frac{6.125 \times 10^{-8} \text{ m}}{500 \frac{\text{m}}{\text{s}}} = 1.225 \times 10^{-10} \text{ s}. \quad (1.40)$$

1.8 Properties and state of a substance

We define

- **PHASE:** a quantity of matter that is homogeneous throughout, and
- **PHASE BOUNDARIES:** interfaces between different phases.

An example of a single phase is ice. Another single phase is liquid water. A glass of ice water is a two-phase mixture with the phase boundaries at the edge of each ice cube.

We next define (circularly)

- **STATE:** condition described by observable macroscopic properties, and
- **PROPERTY:** quantity that only depends on the state of the system and is independent of the history of the system.

Examples of properties include temperature and pressure. Two states are equivalent if they have the same properties. So if state 1 is defined by temperature T_1 and pressure P_1 , and state 2 is defined is by temperature T_2 and P_2 , state 1 is equivalent to state 2 iff (that is, *if and only if*) $T_1 = T_2$ and $P_1 = P_2$.

There are two important classes of properties we consider in thermodynamics:

- **EXTENSIVE PROPERTY:** a property that depends on the mass (or the *extent*) of the system, example extensive properties include mass, total volume, total energy, and
- **INTENSIVE PROPERTY:** a property that is independent of the mass of the system. Example intensive properties include temperature and pressure.

In general, if you cut a system in half and re-measure its properties, intensive properties remain unchanged, while extensive properties are cut in half. Properties are defined for systems that are in

- **EQUILIBRIUM:** state in which no spontaneous changes are observed with respect to time.

We actually never totally achieve equilibrium, we only approximate it. It takes infinite time to achieve final equilibrium. In this class we will mainly be concerned with two types of equilibrium:

- **MECHANICAL EQUILIBRIUM:** characterized by equal pressure, and
- **THERMAL EQUILIBRIUM:** characterized by equal temperature.

A third type of equilibrium is chemical equilibrium, that we will not consider here, and is characterized by equal chemical potentials.

A difficult conceptual challenge of thermodynamics is to reckon with two systems initially at their own equilibria, to bring them into contact so that they find a new equilibria. How to do this without consideration of time can be difficult. Another branch of thermodynamics, that we will consider only briefly in this course is

- **NON-EQUILIBRIUM THERMODYNAMICS:** branch of thermodynamics that considers systems often far from equilibrium and the time-dynamics of their path to equilibrium.

We will go to great effort to construct a thermodynamics that is generally not burdened with time. Occasionally we will bring time into our problems. Unfortunately, ignoring time occasionally requires some mental contortions, as seen in the next section.

1.9 Processes and cycles

Often systems undergo a

- **CHANGE OF STATE:** implies one or more properties of the system has changed.

How these properties would change outside of time is curiously outside the framework of equilibrium thermodynamics! The best way to think of them is that the changes are slow relative to the underlying molecular time scales. Fortunately, this will allow us to do a wide variety of problems of engineering relevance.

We also define a

- **PROCESS:** a succession of changes of state.

We assume our processes are all sufficiently slow such that each stage of the process is near equilibrium. Certain common processes are given special names, based on the Greek *ἴσος*, *isos*, meaning “equal”:

- **ISOTHERMAL:** constant temperature,
- **ISOBARIC:** constant pressure, and
- **ISOCHORIC:** constant volume.

An important notion in thermodynamics is that of a

- **CYCLE:** series of processes that returns to the original state.

The cycle is a thermodynamic “round trip.”

1.10 Fundamental variables and units

We will mainly use the *Système International* (SI) units in this course. Occasionally, we will use the English Engineering system of units. As found in US National Institute of Standards and Technology (NIST) documents, the important fundamental base SI units, and corresponding English units are

- LENGTH:
 - METER (m): the length of the path traveled by light in vacuum during a time interval of $1/299792458$ of a second, and
 - FOOT (ft),
- TIME:
 - SECOND: (s) the duration of 9192631770 periods of the radiation corresponding to the transition between the two hyperfine levels of the ground state of the cesium 133 atom, and
 - SECOND: (s) English time units are identical to those of SI,
- MASS:
 - KILOGRAM (kg): until May 2019 was defined as a mass equal to the mass of the international prototype of the kilogram (a platinum-iridium bar stored in Paris), roughly equal to the mass of one liter of water at standard temperature and pressure; its new definition is such that it is defined by taking the fixed numerical value of the Planck constant h to be $6.62607015 \times 10^{-34}$ when expressed in the unit J s, that is equal to $\text{kg m}^2 \text{s}^{-1}$, and
 - POUND MASS: (lbm),
- TEMPERATURE: an equilibrium property that roughly measures how hot or cold an object is. Note our senses are poor judges of temperature. Consider snow and air in thermal equilibrium at 20°F . Usually, it is possible to keep your bare hands warm for many hours at 20°F if you are otherwise dressed warmly. However, if you place your bare hand in a snow bank you for a few minutes, you have a danger of frostbite. Yet both are at the same temperature. Why the difference in sense? Our bodies actually have more sensitivity to heat fluxes instead of temperature; heat leaves our body more rapidly when in contact with high density objects like snow relative to that of low density objects like air. More fundamental than common units such as $^\circ\text{F}$ are so-called absolute temperature units:
 - KELVIN: (K) until recently, the fraction $1/273.16$ of the thermodynamic temperature of the triple point of water, and since May 2019 defined by taking the fixed numerical value of the Boltzmann constant k_B to be 1.380649×10^{-23} when expressed in the unit J K^{-1} , that is equal to $\text{kg m}^2 \text{s}^{-2} \text{K}^{-1}$, and

– RANKINE: ($^{\circ}\text{R}$).

1.11 Zeroth law of thermodynamics

In this class we are taking the axiomatic approach. Recall that an axiom cannot be proven. It is a statement whose truth can be ascertained only by comparison with experiment. The axiom can be disproved by a single negative experiment. The so-called zeroth law of thermodynamics is the axiom that is probably most fundamental. It was formalized after the so-called first and second laws, and so it is called the zeroth law. Perhaps if a more fundamental axiom were discovered, it would be called the -1^{st} law of thermodynamics?

- **ZEROTH LAW OF THERMODYNAMICS:** When two bodies have equality of temperature with a third body, then they have equality of temperature.

The origins of the zeroth law are murky. Sommerfeld¹³ attributes the notion to R. H. Fowler in a 1931 review of a thermodynamics book. Fowler and Guggenheim explicitly introduce the term “zeroth law of thermodynamics” later.¹⁴ The equivalent statement in mathematical logic is that if $x = y$ and $x = z$, then $y = z$; this is in fact equivalent to the first of Euclid’s common notions: things that are equal to the same thing are also equal to each other.

Definition of the zeroth law enables the use of a thermometer as a measurement device. A scale however needs to be defined. The old metric temperature scale, Celsius ($^{\circ}\text{C}$), was defined so that

- 0°C is the freezing point of water, and
- 100°C is the boiling point of water.

These quantities varied with pressure however, so that different values would be obtained on top of a mountain versus down in the valley, and so this is not a good standard. Until May 2019, the Celsius scale was defined to be nearly the same, but had

- 0.01°C as the so-called triple point of water, and
- -273.15°C as absolute zero in K.

The triple point of water is defined at the state where three phases of water (solid, liquid, and gas) are observed to co-exist. Now it is defined in terms of the Boltzmann constant on a similar basis as the Kelvin scale, in such a way that the triple point of water remains, within the limits of experimental error, at 0.01°C . The transformation between the absolute Kelvin scale and the Celsius scale is given by

$$\text{K} = ^{\circ}\text{C} + 273.15. \quad (1.41)$$

¹³A. Sommerfeld, 1956, *Thermodynamics and Statistical Mechanics*, Lectures on Theoretical Physics, Vol. V, Academic Press, New York, p. 1.

¹⁴R. Fowler and E. A. Guggenheim, 1939, *Statistical Thermodynamics: A Version of Statistical Mechanics for Students of Physics and Chemistry*, Cambridge University Press, Cambridge, p. 56.

The English equivalents are degrees Fahrenheit ($^{\circ}\text{F}$) for relative temperature and degrees Rankine ($^{\circ}\text{R}$) for absolute temperature. The conversions are

$$T(^{\circ}\text{R}) = 1.8T(\text{K}), \quad T(^{\circ}\text{F}) = 1.8T(^{\circ}\text{C}) + 32, \quad T(^{\circ}\text{F}) = T(^{\circ}\text{R}) - 459.67. \quad (1.42)$$

1.12 Secondary variables and units

Many units can be derived from the base units. Some important units for thermodynamics include

- **FORCE:** This unit is defined from Newton's second law, $m \, d^2y/dt^2 = \sum F$.
 - **NEWTON:** (N), $1 \text{ N} = 1 \frac{\text{kg} \cdot \text{m}}{\text{s}^2}$, and
 - **POUND FORCE:** (lbf).

Force is straightforward in SI units. It is more confusing in English units, where the so-called gravitational constant g_c is often introduced. In SI units, $g_c = 1$. However in English units, the law for force is better stated as

$$\frac{1}{g_c} m \frac{d^2y}{dt^2} = \sum F. \quad (1.43)$$

Moreover, a gravitational body force is better stated as mg/g_c in English units. Now, 1 lbf is induced by a mass of 1 lbm in places where local gravitational acceleration is $g = 32.1740 \text{ ft/s}^2$. Let us consider two important types of problems

- *acceleration of a particle in a uniform gravitational field:* Here the only force acting on the particle is the body force, $-mg/g_c$, and Eq. (1.43) reduces to

$$\frac{1}{g_c} m \frac{d^2y}{dt^2} = -\frac{mg}{g_c}, \quad (1.44)$$

$$\frac{d^2y}{dt^2} = -g, \quad (1.45)$$

$$\frac{dy}{dt} = -gt + C_1, \quad (1.46)$$

$$y = -\frac{1}{2}gt^2 + C_1t + C_2. \quad (1.47)$$

Note that g_c plays no role whatsoever in determining the position of the particle.

- *static force balance:* Here one wants to determine the force necessary to hold a particle stationary in a uniform gravitational field. In such a problem the

acceleration is zero, but there are two forces, the gravitational force $-mg/g_c$, and the counter-balancing force that we will call F . Eq. (1.43) reduces to

$$\frac{1}{g_c} m \underbrace{\frac{d^2 y}{dt^2}}_{=0} = F - \frac{mg}{g_c}, \quad (1.48)$$

$$0 = F - \frac{mg}{g_c}, \quad (1.49)$$

$$F = \frac{mg}{g_c}. \quad (1.50)$$

If we are at a location where $g = 32.1740 \text{ ft/s}^2$, we can consider the counter-balancing force necessary to hold 1 lbf stationary, via Eq. (1.50):

$$F = 1 \text{ lbf} = \frac{(1 \text{ lbf}) \left(32.1740 \frac{\text{ft}}{\text{s}^2}\right)}{g_c}. \quad (1.51)$$

Thus,

$$g_c = 32.1740 \frac{\text{lbf ft}}{\text{lbf s}^2}. \quad (1.52)$$

Example 1.3

If the local gravitational acceleration is 32.0 ft/s^2 , find the weight W of an object with mass of $m = 1000 \text{ lbf}$.

$$W = F = \frac{1}{g_c} mg = \frac{1}{32.1740 \frac{\text{lbf ft}}{\text{lbf s}^2}} (1000 \text{ lbf}) \left(32.0 \frac{\text{ft}}{\text{s}^2}\right) = 994.59 \text{ lbf}. \quad (1.53)$$

Example 1.4

An alternative English unit for mass is the slug with $1 \text{ slug} = 32.1740 \text{ lbf}$. If local gravitational acceleration is 32.0 ft/s^2 , find the weight W of an object with mass of $m = 1 \text{ slug}$.

$$W = F = \frac{1}{g_c} mg = \frac{1}{32.1740 \frac{\text{lbf ft}}{\text{lbf s}^2}} (1 \text{ slug}) \left(\frac{32.1740 \text{ lbf}}{1 \text{ slug}}\right) \left(32.0 \frac{\text{ft}}{\text{s}^2}\right) = 32.0 \text{ lbf}. \quad (1.54)$$

Note, we could also recast g_c in terms of slugs as

$$g_c = \left(32.1740 \frac{\text{lbf ft}}{\text{slug s}^2} \right) \left(\frac{1 \text{ slug}}{32.1740 \text{ lbf}} \right) = 1 \frac{\text{slug ft}}{\text{lbf s}^2}. \quad (1.55)$$

Thus, we could also say

$$W = F = \frac{1}{g_c} mg = \frac{1}{1 \frac{\text{slug ft}}{\text{lbf s}^2}} (1 \text{ slug}) \left(32.0 \frac{\text{ft}}{\text{s}^2} \right) = 32.0 \text{ lbf}. \quad (1.56)$$

Because in this unit system, g_c has a magnitude of unity, it is analogous to the SI system, and the slug is more appropriate than lbf as an analog to the kg. Just as we think of $\text{N} = \text{kg m/s}^2$, we can think of $\text{lbf} = \text{slug ft/s}^2$. Mainly so that consistency can be maintained with BS, we will nearly always use lbf and avoid slugs for mass in the English system.

-
- ENERGY: roughly speaking, the ability to do work, found from the product of force and distance.
 - JOULE: (J), $1 \text{ J} = 1 \text{ (N m)}$, and
 - FOOT-POUND FORCE: (ft lbf).
 - SPECIFIC VOLUME: the volume per unit mass, known as $v = V/m$.
 - $\left(\frac{\text{m}^3}{\text{kg}} \right)$, and
 - $\left(\frac{\text{ft}^3}{\text{lbfm}} \right)$.
 - DENSITY: the mass per unit volume, the inverse of specific volume $\rho = m/V$.
 - $\left(\frac{\text{kg}}{\text{m}^3} \right)$, and
 - $\left(\frac{\text{lbfm}}{\text{ft}^3} \right)$.

Note also that

$$v = \frac{1}{\rho}, \quad \rho = \frac{1}{v}. \quad (1.57)$$

- PRESSURE: the $\lim_{A \rightarrow 0} F/A$ where A is the cross-sectional area and F is the component of force acting normal to that area. In thermodynamics, we are almost always concerned with the *absolute pressure* as opposed to the *gauge pressure*. Most common pressure gauges do not measure the absolute pressure; instead they measure the difference between the absolute pressure and the atmospheric pressure. The two are related via the formula

$$P_{\text{gauge}} = P_{\text{absolute}} - P_{\text{atm}}. \quad (1.58)$$

We nearly always interpret P as an absolute pressure, so we could also say

$$P_{\text{gauge}} = P - P_{\text{atm}}. \quad (1.59)$$

- PASCAL: (Pa), $1 \text{ Pa} = 1 \text{ N/m}^2$; note other common units are $1 \text{ bar} = 10^5 \text{ Pa}$, $1 \text{ atm} = 1.01325 \times 10^5 \text{ Pa} = 101.325 \text{ kPa} = 0.101325 \text{ MPa}$, and
- (psia): $1 \text{ psia} = 1 \text{ lbf/in}^2$. $1 \text{ atm} = 14.696 \text{ psia}$. The a denotes the “absolute” pressure as opposed to the “gauge” pressure. The units psig refer to a gauge pressure.

The SI unit is named after Blaise Pascal, see Fig. 1.20, the French polymath who



Figure 1.20: Blaise Pascal (1623-1662), French scientist and philosopher who considered manometry, among other diverse topics; image from <http://mathshistory.st-andrews.ac.uk/Biographies/Pascal.html>.

conducted early scientific experiments with manometers, a common measuring device for pressure, see Fig. 1.21. There are a variety of styles of manometers. Here, a pipe

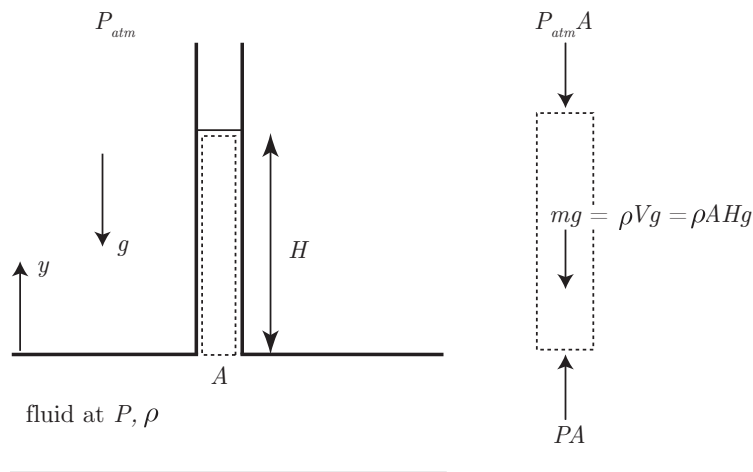

Figure 1.21: Manometer sketch.

containing fluid at pressure P and density ρ has a small tube with cross sectional area

A connecting it to the outside atmosphere at a different pressure P_{atm} . The length H is easily measured. The gravitational acceleration is g and is in the negative y direction. Because $P > P_{atm}$, the manometer fluid is pushed up. However, it finds a mechanical equilibrium where the weight of the manometer fluid balances the net force induced by the pressure differential.

The figure includes a cutaway with a free body diagram. The interior fluid exerts a positive force of PA on the manometer fluid in the cutaway. The atmosphere exerts another force of $P_{atm}A$ in the negative direction. The third force is the weight of the fluid: mg . Thus, Newton's second law tells us

$$m \underbrace{\frac{d^2y}{dt^2}}_{=0} = PA - P_{atm}A - mg. \quad (1.60)$$

Now, we are concerned with cases that are static, in which case the acceleration $d^2y/dt^2 = 0$. Thus, we require a force balance, i.e. mechanical equilibrium, that is achieved when

$$0 = PA - P_{atm}A - mg, \quad (1.61)$$

$$PA = P_{atm}A + mg. \quad (1.62)$$

Now, $mg = \rho Vg$, where V is the volume of the fluid in the cutaway. Obviously from the geometry, we have $V = AH$, so $mg = \rho AHg$. Thus,

$$PA = P_{atm}A + \rho AHg, \quad (1.63)$$

$$P = P_{atm} + \rho gH. \quad (1.64)$$

Or

$$\Delta P = P - P_{atm} = P_{gauge} = \rho gH. \quad (1.65)$$

Example 1.5

A manometer gives a reading of $H = 2$ ft in a region where local $g = 32.2$ ft/s². The working fluid has specific volume $v = 0.0164$ ft³/lbm. The atmospheric pressure is $P_{atm} = 14.42$ lbf/in² = 14.42 psia. Find the fluid pressure.

We know that in the SI system.

$$P = P_{atm} + \rho gH. \quad (1.66)$$

In terms of specific volume, recalling that $\rho = 1/v$, we have

$$P = P_{atm} + \frac{gH}{v}. \quad (1.67)$$

The challenge here is really the English units. A fair way to approach English units is to replace g by g/g_c in every formula. Thus, in English units, we have

$$P = P_{atm} + \frac{1}{v} \frac{g}{g_c} H. \quad (1.68)$$

So our fluid pressure is

$$P = 14.42 \frac{\text{lbf}}{\text{in}^2} + \frac{1}{0.0164 \frac{\text{ft}^3}{\text{lbf}} \left(\frac{32.2 \frac{\text{ft}}{\text{s}^2}}{32.1740 \frac{\text{lbf} \cdot \text{ft}}{\text{lbf} \cdot \text{s}^2}} \right)} (2 \text{ ft}) \left(\frac{1 \text{ ft}}{12 \text{ in}} \right)^2 = 15.27 \frac{\text{lbf}}{\text{in}^2} = \boxed{15.27 \text{ psia.}} \quad (1.69)$$

Chapter 2

Properties of a pure substance

Read BS, Chapter 2

2.1 The pure substance

We define a

- PURE SUBSTANCE: a material with homogeneous and invariable composition.

To elaborate,

- Pure substances can have multiple phases: an ice-water mixture is still a pure substance.
- An air-steam mixture is not a pure substance.
- Air, being composed of a mixture of N_2 , O_2 , and other gases, is formally not a pure substance. However, experience shows that we can often treat air as a pure substance with little error.

2.2 Vapor-liquid-solid phase equilibrium

Often we find that different phases of pure substances can exist in equilibrium with one another. Let us consider an important *gedankenexperiment* (Latin-German for “thought experiment”) in which we boil water. Ordinary water boiling is shown in Fig. 2.1. However, this ordinary experiment has constraints that are too loose. Most importantly, the mass of water leaks into the atmosphere; thus, the water vapor and the air become a mixture and no longer a pure substance.

Let us instead consider a more controlled piston-cylinder arrangement. Inside the cylinder, we begin with pure liquid water at $T = 20^\circ\text{C}$. The piston is free to move in the cylinder, but it is tightly sealed, so no water can escape. On the other side of the piston is a constant pressure atmosphere, that we take to be at $P = 100\text{ kPa} = 0.1\text{ MPa} = 10^5\text{ Pa} = 1\text{ bar}$. We



Figure 2.1: Water boiling isobarically in an *open* environment.

slowly add heat to the cylinder, and observe a variety of interesting phenomena. A sketch of what we observe is given in Fig. 2.2. We notice the following behavior:

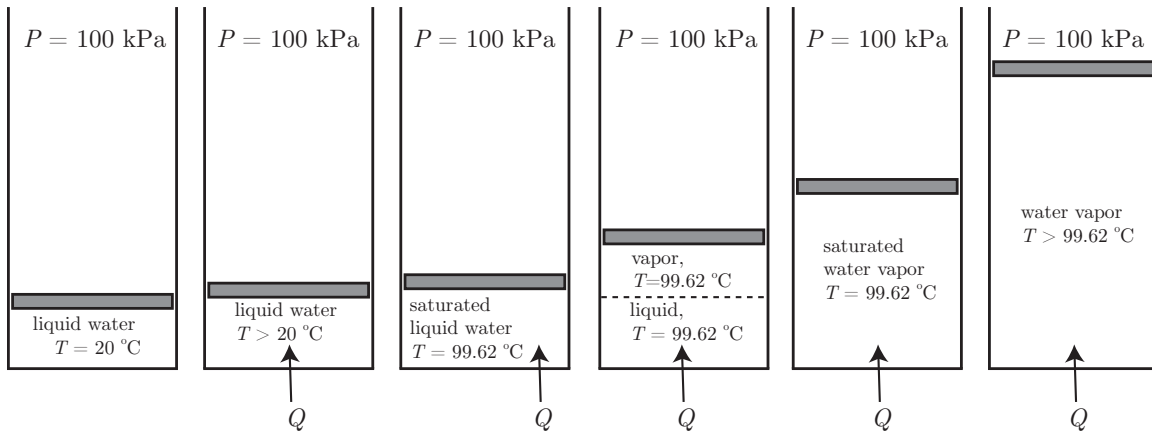

Figure 2.2: Sketch of experiment in which heat is added isobarically to water in a *closed* piston-cylinder arrangement.

- The pressure remains at a constant value of 100 kPa. This is an isobaric process.
- The total volume increases slightly as heat is added to the liquid.
- The temperature of the liquid increases significantly as heat is added to the liquid.
- At a special value of temperature, observed to be $T = 99.62\text{ }^\circ\text{C}$, we have all liquid, but cannot add any more heat and retain all liquid. We will call this state the *saturated liquid* state. We call $T = 99.62\text{ }^\circ\text{C}$ the *saturation temperature* at $P = 100\text{ kPa}$. As we continue to add heat,

- The temperature remains constant (this is *isothermal* now as well as isobaric).
 - The total volume continues to increase.
 - We notice *two* phases present: liquid and vapor, with a distinct phase boundary. The liquid is dense relative to the vapor. That is $\rho_f > \rho_g$, where f denotes fluid or liquid and g denotes gas or vapor. Thus, $v_g > v_f$.
 - As more heat is added, more vapor appears, all while $P = 100$ kPa and $T = 99.62$ °C.
 - At a certain volume, we have all vapor and no liquid, still at $P = 100$ kPa, $T = 99.62$ °C. We call this state the *saturated vapor* state.
- As heat is added, we find both the temperature and the volume rise, with the pressure remaining constant. The water remains in the all vapor state.

We have just boiled water! We sketch this process in the temperature-specific volume plane, that is, the $T - v$ plane, in Fig. 2.3. Note that the mass m of the water is constant in this

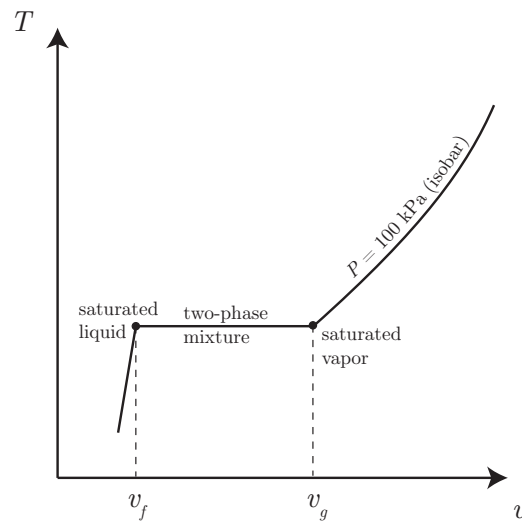

Figure 2.3: Isobar in the $T - v$ plane for our thought experiment in which heat is added isobarically to water in a piston-cylinder arrangement.

problem, so the extensive V is strictly proportional to specific volume, $v = V/m$.

We next repeat this experiment at lower pressure (such as might exist on a mountain top) and at a higher pressure (such as might exist in a valley below sea level). For moderate pressures, we find qualitatively the exact same type of behavior. The liquid gets hotter, turns into vapor isothermally, and then the vapor gets hotter as the heat is added. However, we note the following important facts:

- The saturation temperature (that is the boiling point) increases as pressure increases, as long as the pressure increase is not too high.

- As pressure increases v_f becomes closer to v_g .
- Above a *critical pressure*, $P = P_c = 22.089$ MPa, there is no phase change observed!¹ At the critical pressure, the temperature takes on a *critical temperature* of $T_c = 374.14$ °C. At the critical pressure and temperature, the specific volume takes the value $v_f = v_g = v_c = 0.003155$ m³/kg.

We see how the boiling point changes with pressure by plotting the saturation pressure as a function of saturation temperature in the $T - P$ plane in Fig. 2.4. This is the so-called vapor pressure curve. Here, we focus on liquid-vapor mixtures and keep T high enough to

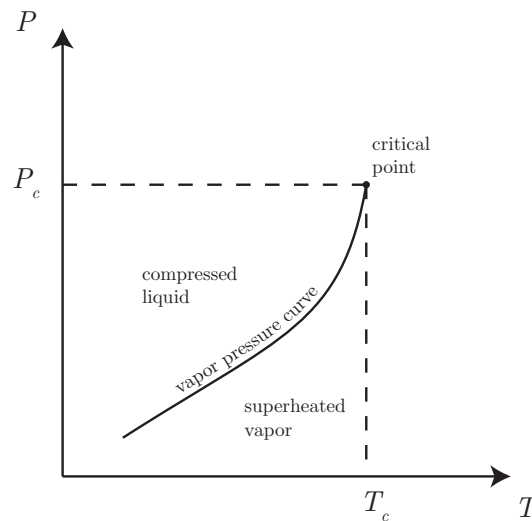

Figure 2.4: Saturation pressure versus saturation temperature sketch.

prevent freezing. Note the curve terminates abruptly at the *critical point*.

We adopt the following nomenclature:

- SATURATED LIQUID: the material is at T_{sat} and is all liquid.
- SATURATED VAPOR: the material is at T_{sat} and is all vapor.
- COMPRESSED (SUBCOOLED) LIQUID: the material is liquid with $T < T_{sat}$.
- SUPERHEATED VAPOR: the material is vapor with $T > T_{sat}$.
- TWO-PHASE MIXTURE: the material is composed of co-existing liquid and vapor with both at T_{sat} .

¹This behavior may have first been carefully documented by T. Andrews, 1869, “The Bakerian lecture: on the continuity of the gaseous and liquid states of matter,” *Philosophical Transactions of the Royal Society of London*, 159: 575-590.

For two-phase mixtures, we define a new property to characterize the relative concentrations of liquid and vapor. We define the

- QUALITY= x : as the ratio of the mass of the mixture that is vapor (vap) to the total mixture mass:

$$x = \frac{m_{vap}}{m_{total}}. \quad (2.1)$$

We can also take the total mass to be the sum of the liquid and vapor masses:

$$m_{total} = m_{liq} + m_{vap}. \quad (2.2)$$

So

$$x = \frac{m_{vap}}{m_{liq} + m_{vap}}. \quad (2.3)$$

There are two important limits to remember:

- $x = 0$: corresponds to $m_{vap} = 0$. This is the all liquid limit.
- $x = 1$: corresponds to $m_{vap} = m_{total}$. This is the all gas limit.

We must have

$$x \in [0, 1]. \quad (2.4)$$

We sketch water's $T - v$ plane again for a wide variety of isobars in Fig. 2.5. We sketch

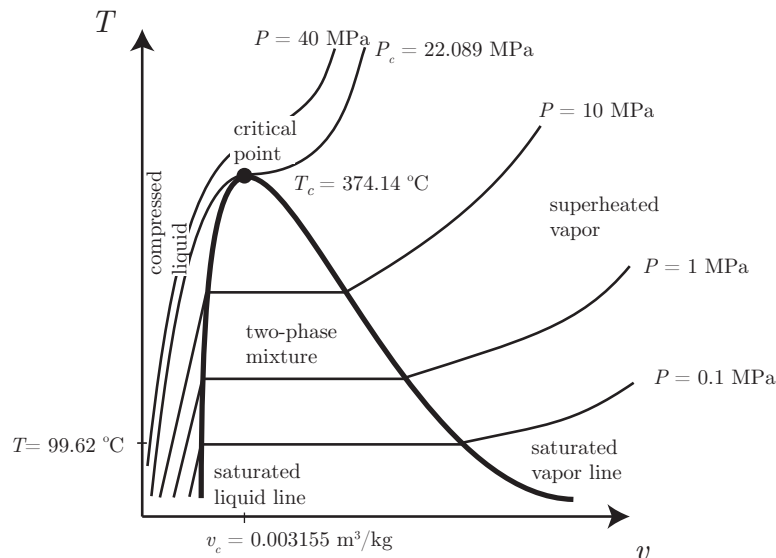

Figure 2.5: Sketch of $T - v$ plane for water for a variety of isobars.

water's $P - v$ plane for a wide variety of isotherms in Fig. 2.6. We can perform a similar thought experiment for ice. We can start with ice at $P = 100$ kPa and add heat to it. We

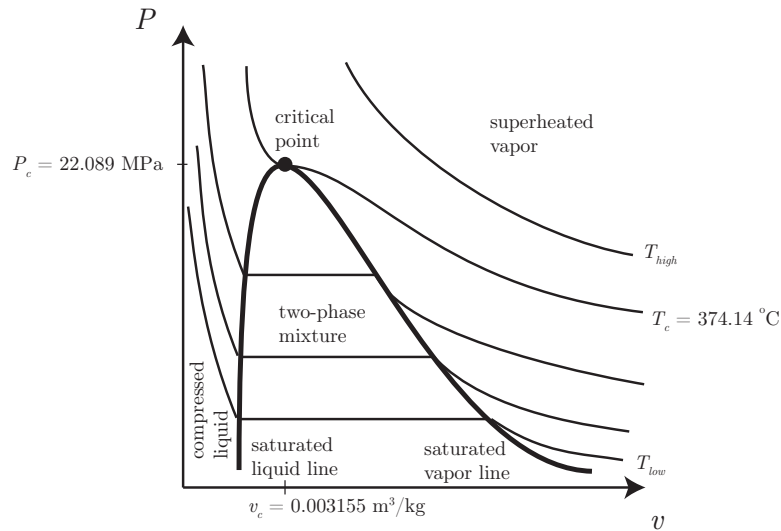

Figure 2.6: Sketch of $P - v$ plane for water for a variety of isotherms.

observe the ice's temperature rise until $T = T_{sat} \sim 0^\circ\text{C}$. At that temperature, the ice begins to melt and the temperature remains constant until all the ice is melted. At this point the liquid temperature begins to rise. If we continued to add heat, we would boil the water.

We note if we perform this experiment for $P < 0.6113\text{ kPa}$ the ice in fact goes directly to vapor. It is said to have undergone *sublimation*. There exists a second important point where ice being heated isobarically can transform into either liquid or gas. This is the so-called *triple point*. At the triple point we find the saturation pressure and temperature are $P_{tp} = 0.6113\text{ kPa}$ and $T_{tp} = 0.01^\circ\text{C}$, respectively. It is better described as a triple line, because in the $P - v - T$ space we will study, it appears as a line with constant P and T , but variable v . In the $P - T$ projected plane of the $P - v - T$ volume, it projects as a point. We sketch water's $P - T$ plane again for a wider range to include the vapor-liquid-solid phase behavior in Fig. 2.7.

These characteristics apply to all pure substances. For example, nitrogen has a triple point and a critical point. Table A.2 in BS lists critical constants for many materials. Note also that phase transitions can occur within solid phases. This involves a re-arrangement of the crystal structure. This has important implications for material science, but will not be considered in detail in this course.

2.3 Independent properties

Let us define a

- **SIMPLE COMPRESSIBLE SUBSTANCE:** a material that can be worked upon by pressure forces.

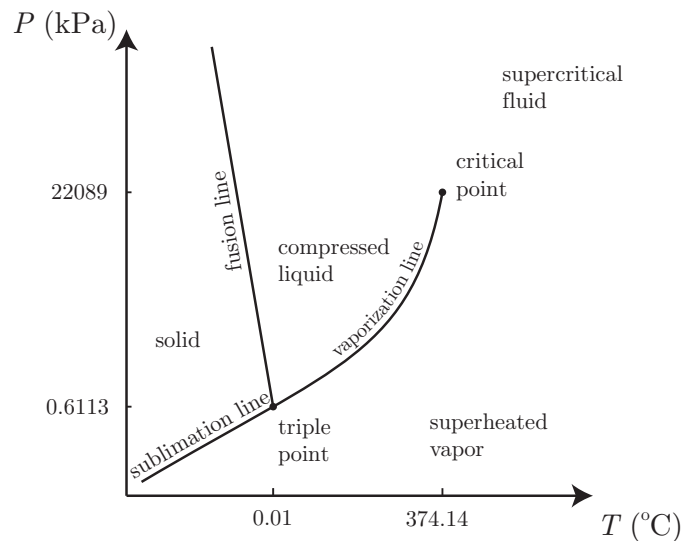

Figure 2.7: Sketch of $P - T$ plane for water.

Note we neglect electric, magnetic, and chemical work modes. While this is indeed restrictive, it will be important for many mechanical engineering applications. The following important statement can be proved (but will not be so here):

- *For a simple compressible substance, two independent intensive thermodynamic properties define the state of the system.*

Consider the implications for

- *superheated vapor:* If we consider P , T , and v , this states that we must allow one of the variables to be functions of the other two. We could have $P = P(T, v)$, $v = v(T, P)$, or $T = T(P, v)$. All are acceptable.
- *two-phase mixture:* If we have a two-phase mixture, our experiments show that P and T are not independent. In this case, we need another property to characterize the system. That property is the quality, x . So for two-phase mixtures, we might have $v = v(T, x)$, for example.

2.4 Thermal equations of state

Here, we will describe some of the many different ways to capture the relation between two independent properties and a third dependent property for a simple compressible substance. We will focus on a so-called

- **THERMAL EQUATION OF STATE:** an equation that gives the pressure as a function of two independent state variables. An example is the general form:

$$P = P(T, v). \quad (2.5)$$

We will progress from simple thermal equations of state to more complex.

2.4.1 Ideal gas law

For many gases, especially at low density and far from the critical point, it is possible to write a simple thermal equation of state that accurately describes the relation between pressure, volume, and temperature. Such equations were developed in the 1600s and early 1800s based entirely on macroscopic empirical observation. In the late 1800s, statistical mechanics provided a stronger theoretical foundation for them, but we will not consider that here.

Let us start with the most important equation of state:

- IDEAL GAS LAW: This equation, which is a combination of *Boyle's law*,² *Charles' law*,³ and *Avogadro's law*,⁴ is most fundamentally stated as

$$PV = n\bar{R}T. \quad (2.6)$$

On the continent, Boyle's law is sometimes known as Mariotte's law after Edme Mariotte (1620-1684), but Boyle published it fourteen years earlier.⁵ A reproduction of Boyle's data is given in Fig. 2.8.⁶ The data in $(V, 1/P)$ space is fit well by a straight line with intercept at the origin; that is $1/P = KV$, where K is a constant. Thus, $PV = C$, where $C = 1/K$ is a constant.

²R. Boyle, 1662, *New Experiments Physico-Mechanical, Touching the Air: Whereunto is Added A Defence of the Authors Explication of the Experiments, Against the Objections of Franciscus Linus and Thomas Hobbes*, H. Hall, Oxford. There exists a 1725 text modified from the 1662 original in *The Philosophical Works of Robert Boyle*, Vol. 2, P. Shaw, ed., Innis, Osborn, and Longman, London. Boyle's law holds that PV is constant in an isothermal process.

³attributed to J. A. C. Charles by J. L. Gay-Lussac, 1802, "Recherches sur la dilatation des gaz des vapeurs," *Annales de Chimie*, 43(1): 137-175. Charles' law holds that V/T is constant for ideal gases undergoing isobaric processes. Additionally, Guillaume Amontons (1663-1705) performed some of the early experimentation that led to Charles' law. John Dalton (1766-1844) is said to have also written on a version of Charles' Law in 1801.

⁴A. Avogadro, 1811, "Essai d'une manière de déterminer les masses relatives des molécules élémentaires des corps, et les proportions selon lesquelles elles entrent dans ces combinaisons," *Journal de Physique, de Chimie et d'Histoire Naturelle*, 73:58-76. Here, Avogadro hypothesized that "equal volumes of ideal or perfect gases, at the same temperature and pressure, contain the same number of particles, or molecules."

⁵C. Webster, 1965, "The discovery of Boyle's law, and the concept of the elasticity of air in the seventeenth century," *Archive for History of Exact Sciences*, 2(6): 441-502. Also described here is how Henry Power (1623-1668) and Richard Towneley (1629-1707) did important preliminary work that helped Boyle formulate his law.

⁶see J. B. West, 1999, "The original presentation of Boyle's law," *Journal of Applied Physiology*, 98(1): 31-39.

A table of the condensation of the air.

| <i>A</i> | <i>A</i> | <i>B</i> | <i>C</i> | <i>D</i> | <i>E</i> |
|----------|-----------------|-------------------|----------|--------------------|-------------------|
| 48 | 12 | 00 | | $29\frac{2}{18}$ | $29\frac{2}{18}$ |
| 46 | $11\frac{1}{2}$ | $01\frac{7}{18}$ | | $30\frac{9}{18}$ | $33\frac{6}{18}$ |
| 44 | 11 | $02\frac{13}{18}$ | | $31\frac{15}{18}$ | $31\frac{13}{18}$ |
| 42 | $10\frac{1}{2}$ | $04\frac{6}{18}$ | | $33\frac{9}{18}$ | $33\frac{7}{7}$ |
| 40 | 10 | $06\frac{12}{18}$ | | $35\frac{18}{18}$ | 35 - |
| 38 | $9\frac{1}{2}$ | $07\frac{18}{18}$ | | 37 | $36\frac{15}{18}$ |
| 36 | 9 | $10\frac{15}{18}$ | | $39\frac{15}{18}$ | $38\frac{7}{7}$ |
| 34 | $8\frac{1}{2}$ | $12\frac{6}{18}$ | | $41\frac{10}{18}$ | $41\frac{12}{17}$ |
| 32 | 8 | $15\frac{1}{18}$ | | $44\frac{3}{18}$ | $43\frac{11}{16}$ |
| 30 | $7\frac{1}{2}$ | $17\frac{15}{18}$ | | $47\frac{15}{18}$ | $46\frac{3}{7}$ |
| 28 | 7 | $21\frac{3}{18}$ | | $50\frac{12}{18}$ | 50 - |
| 26 | $6\frac{1}{2}$ | $25\frac{15}{18}$ | | $54\frac{15}{18}$ | $53\frac{10}{17}$ |
| 24 | 6 | $29\frac{1}{18}$ | | $58\frac{12}{18}$ | $58\frac{2}{7}$ |
| 23 | $5\frac{3}{4}$ | $32\frac{12}{18}$ | | $61\frac{15}{18}$ | $60\frac{11}{17}$ |
| 22 | $5\frac{1}{2}$ | $34\frac{15}{18}$ | | $64\frac{15}{18}$ | $63\frac{6}{17}$ |
| 21 | $5\frac{1}{4}$ | $37\frac{15}{18}$ | | $67\frac{15}{18}$ | $66\frac{4}{7}$ |
| 20 | 5 | $41\frac{9}{18}$ | | $70\frac{12}{18}$ | 70 - |
| 19 | $4\frac{3}{4}$ | 45 - | | $74\frac{12}{18}$ | $73\frac{11}{17}$ |
| 18 | $4\frac{1}{2}$ | $48\frac{12}{18}$ | | $77\frac{14}{18}$ | $77\frac{2}{7}$ |
| 17 | $4\frac{1}{4}$ | $53\frac{15}{18}$ | | $82\frac{12}{18}$ | $82\frac{4}{17}$ |
| 16 | 4 | $58\frac{6}{18}$ | | $87\frac{14}{18}$ | $87\frac{7}{7}$ |
| 15 | $3\frac{3}{4}$ | $63\frac{15}{18}$ | | $93\frac{18}{18}$ | $93\frac{1}{7}$ |
| 14 | $3\frac{1}{2}$ | $71\frac{15}{18}$ | | $100\frac{7}{18}$ | $99\frac{6}{7}$ |
| 13 | $3\frac{1}{4}$ | $78\frac{15}{18}$ | | $107\frac{15}{18}$ | $107\frac{1}{17}$ |
| 12 | 3 | $88\frac{7}{18}$ | | $117\frac{9}{18}$ | $116\frac{7}{7}$ |

Added to $22\frac{1}{2}$ makes

AA. The number of equal spaces in the shorter leg, that contained the same parcel of air diversly extended.

B. The height of the mercurial cylinder in the longer leg, that compressed the air into those dimensions.

C. The height of the mercurial cylinder, that counter-balanced the pressure of the atmosphere.

D. The aggregate of the two last columns *B* and *C*, exhibiting the pressure sustained by the included air.

E. What that pressure should be according to the hypothesis, that supposes the pressures and expansions to be in reciprocal proportion.

a)

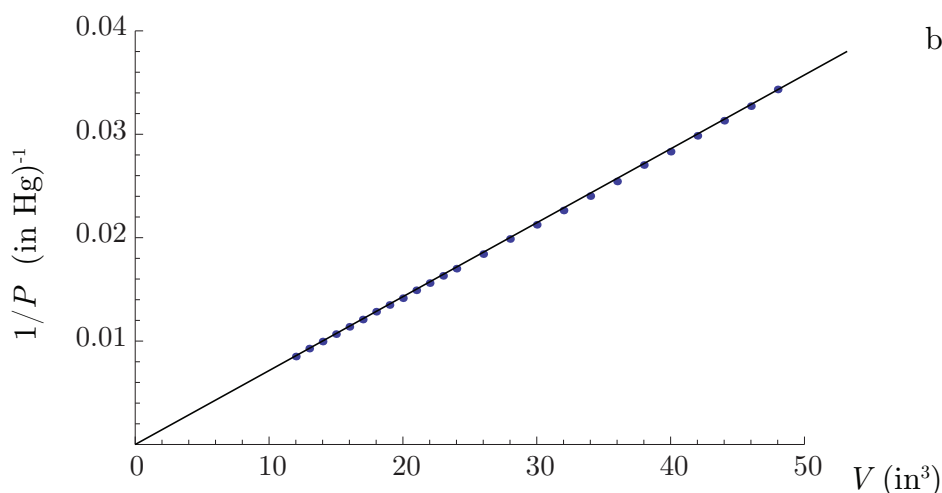

b)

Figure 2.8: a) Boyle's 1662 data to validate his law (PV is constant for an isothermal process), b) plot of Boyle's data: V (the left-most of the columns labelled *A*) versus reciprocal of P (reciprocal of column *D*), demonstrating its near linearity.

Depictions of Boyle, Charles, and Avogadro are given in Fig. 2.9. The ideal gas law was



Figure 2.9: b) Robert Boyle (1627-1691), Irish scientist who developed an important special case of the ideal gas law. Image from https://en.wikipedia.org/wiki/Robert_Boyle, c) Jacques Alexandre César Charles (1746-1823), French scientist credited in 1802 by Joseph Louis Gay-Lussac (1778-1850) for developing an important special case of the ideal gas law in the 1780s. Image from https://en.wikipedia.org/wiki/Jacques_Charles, a) Lorenzo Romano Amedeo Carlo Avogadro di Quarengna e di Cerreto (1776-1856), Italian physicist, nobleman, and revolutionary. Image from https://en.wikipedia.org/wiki/Amedeo_Avogadro.

first stated in the form roughly equivalent to Eq. (2.6) by Clapeyron,⁷ depicted in Fig. 2.10.

It is critical that the temperature here be the absolute temperature. For the original argument, see Thomson.⁸ Here, n is the number of moles. Recall there are $\mathcal{N} = 6.02214179 \times 10^{23}$ molecules in a mole, where \mathcal{N} is Avogadro's number. Also \bar{R} is the *universal gas constant*, whose history is recounted by Jensen.⁹ From experiment, many performed by Regnault, depicted in Fig. 2.11, it is determined to be

$$\bar{R} = 8.314472 \frac{\text{kJ}}{\text{kmole K}}. \quad (2.7)$$

In this class the over bar notation will denote an intensive property on a per mole basis. Intensive properties without over bars will be on a per mass basis. Recall the mass-basis

⁷É. Clapeyron, 1834, “Mémoire sur la puissance motrice de la chaleur,” *Journal de l'École Polytechnique*, 14: 153-190.

⁸W. Thomson, 1848, “On an absolute thermometric scale founded on Carnot's theory of the motive power of heat and calculated from Regnault's observations,” *Proceedings of the Cambridge Philosophical Society*, 1(5): 66-71.

⁹W. B. Jensen, 2003, “The universal gas constant R ,” *Journal of Chemical Education*, 80(7): 731-732.

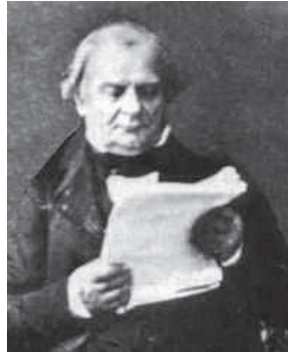

Figure 2.10: Benoît Paul Émile Clapeyron (1799-1824), French engineer and physicist who furthered the development of thermodynamics. Image from https://en.wikipedia.org/wiki/Emile_Clapeyron.

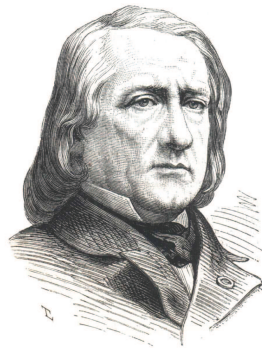

Figure 2.11: Henri Victor Regnault (1810-1878), French chemist and physicist who made careful early measurements of thermodynamic parameters for ideal and non-ideal gases. https://en.wikipedia.org/wiki/Henri_Victor_Regnault.

specific volume is $v = V/m$. Let us define the mole-based specific volume as

$$\bar{v} = \frac{V}{n}. \quad (2.8)$$

Thus, the ideal gas law can be represented in terms of intensive properties as

$$P \underbrace{\frac{V}{n}}_{=\bar{v}} = \bar{R}T, \quad (2.9)$$

$$P\bar{v} = \bar{R}T. \quad (2.10)$$

There are other ways to write the ideal gas law. Recall the molecular mass M is the mass in g of a mole of substance. More common in engineering, it is the mass in kg of a kmole of substance. These numbers are the same! From chemistry, for example, we know

the molecular mass of O_2 is 32 g/mole = 32 kg/kmole. Symbolically, we can say that

$$M = \frac{m}{n}. \quad (2.11)$$

Now, take the ideal gas law and divide by m :

$$PV = n\bar{R}T, \quad (2.12)$$

$$P \underbrace{\frac{V}{m}}_{=v} = \underbrace{\frac{n}{m}}_{=1/M} \bar{R}T, \quad (2.13)$$

$$Pv = \underbrace{\frac{\bar{R}}{M}}_{\equiv R} T. \quad (2.14)$$

Now, let us define

$$R \equiv \frac{\bar{R}}{M}. \quad (2.15)$$

Let us check the units:

$$[R] = \frac{\text{kJ}}{\text{kmole K}} \frac{\text{kmole}}{\text{kg}} = \frac{\text{kJ}}{\text{kg K}}. \quad (2.16)$$

We have actually just lost some universality. Recall \bar{R} is independent of material. But because each different gas has a different M , then *each gas will have its own R* . These values for various gases are tabulated in Table A.5 of BS.

With this definition, the ideal gas law becomes

$$\boxed{Pv = RT}. \quad (2.17)$$

This is the form we will use most often in this class. Note the useful fact that

$$\frac{Pv}{T} = R. \quad (2.18)$$

Thus, if an ideal gas undergoes a process going from state 1 to state 2, we can safely say

$$\boxed{\frac{P_1 v_1}{T_1} = \frac{P_2 v_2}{T_2}}. \quad (2.19)$$

Example 2.1

Find R for air.

We can model air as a mixture of N_2 and O_2 . Its average molecular mass is known from Table A.5 of BS to be $M = 28.97$ kg/kmole. So R for air is

$$R = \frac{\bar{R}}{M} = \frac{8.3145 \frac{\text{kJ}}{\text{kmole K}}}{28.97 \frac{\text{kg}}{\text{kmole}}} = 0.287 \frac{\text{kJ}}{\text{kg K}}. \quad (2.20)$$

Consider some notions from algebra and geometry. The function $f(x, y) = 0$ describes a curve in the $x - y$ plane. In special cases, we can solve for y to get the form $y = y(x)$. The function $f(x, y, z) = 0$ describes a surface in the $x - y - z$ volume. In special cases, we can solve for z to get $z = z(x, y)$ to describe the surface in the $x - y - z$ volume.

Example 2.2

Analyze the surface described by $f(x, y, z) = z^2 - x^2 - y^2 = 0$.

Here, we can solve for z exactly to get

$$z = \pm\sqrt{x^2 + y^2}. \quad (2.21)$$

This surface is plotted in Fig. 2.12. We can also get three two-dimensional projections of this surface

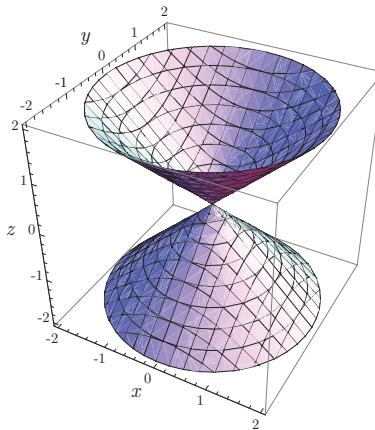

Figure 2.12: The surface $z^2 - x^2 - y^2 = 0$.

in the $x - y$ plane, the $y - z$ plane, and the $x - z$ plane. Orthographic projections of this surface are plotted in Fig. 2.13.

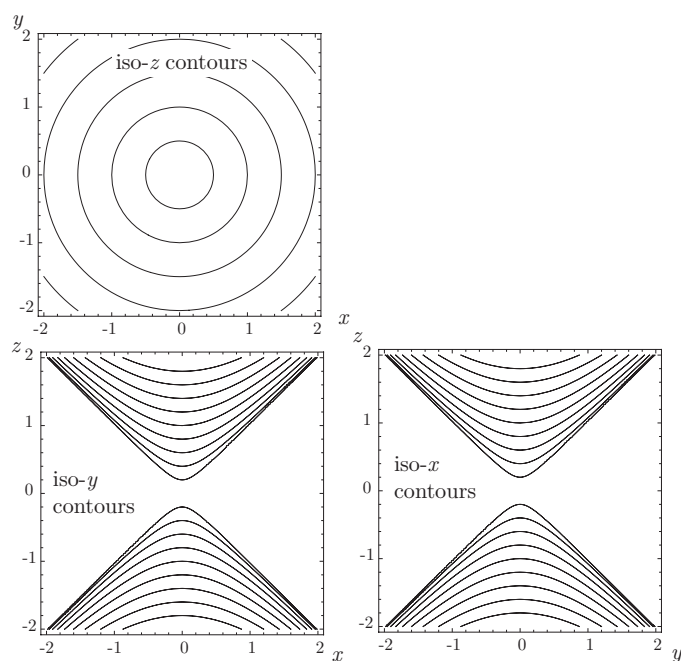

Figure 2.13: Contours of constant x , y and z in orthographic projection planes of the surface $z^2 - x^2 - y^2 = 0$.

For the $x - y$ plane we consider

$$z_o = \pm\sqrt{x^2 + y^2}. \quad (2.22)$$

for various values of z_o . This yields a family of circles in this plane. For the $y - z$ plane, we consider

$$x_o = \pm\sqrt{z^2 - y^2}. \quad (2.23)$$

This gives a family of hyperbolas. For real x_o , we require $z^2 \geq y^2$. For the $z - x$ plane, we consider

$$y_o = \pm\sqrt{z^2 - x^2}. \quad (2.24)$$

This gives a similar family of hyperbolas. For real y_o , we require $z^2 \geq x^2$.

Similarly, the ideal gas equation $P(v, T) = RT/v$ describes a surface in the $P - v - T$ volume. A surface for air is shown in Fig. 2.14. Often, it is easier to understand the behavior

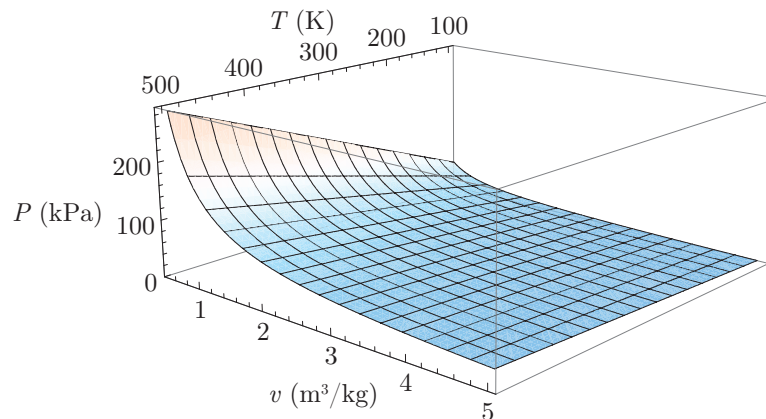

Figure 2.14: Thermodynamic surface for air modeled as an ideal gas.

of the thermodynamic surfaces by projection into various thermodynamic planes and plotting various iso-contours. Let us do this for an ideal gas.

- isobars:

- Consider curves in the $T - v$ plane on which P is constant. Thus, for the ideal gas, we consider

$$T = \underbrace{\left(\frac{P}{R}\right)}_{\text{slope}} v. \quad (2.25)$$

If we insist that P is constant, this gives the equation of an isobar in the $T - v$ plane. Moreover, for the ideal gas, we see that in the $T - v$ plane isobars are *straight lines* with slope P/R . The slope is always positive because $P > 0$ and $R > 0$. So if the pressure is high, the slope is positive and steep. If the pressure is low, the slope is positive and shallow.

- Consider curves in the $P - v$ plane in which P is constant. Thus, we consider

$$P = \text{constant}, \quad (2.26)$$

that are straight horizontal lines in the $P - v$ plane.

- Consider curves in the $P - T$ plane in which P is a constant. Thus, we consider

$$P = \text{constant}, \quad (2.27)$$

that are straight horizontal lines in the $P - v$ plane.

Isobars in various planes are shown in Fig. 2.15.

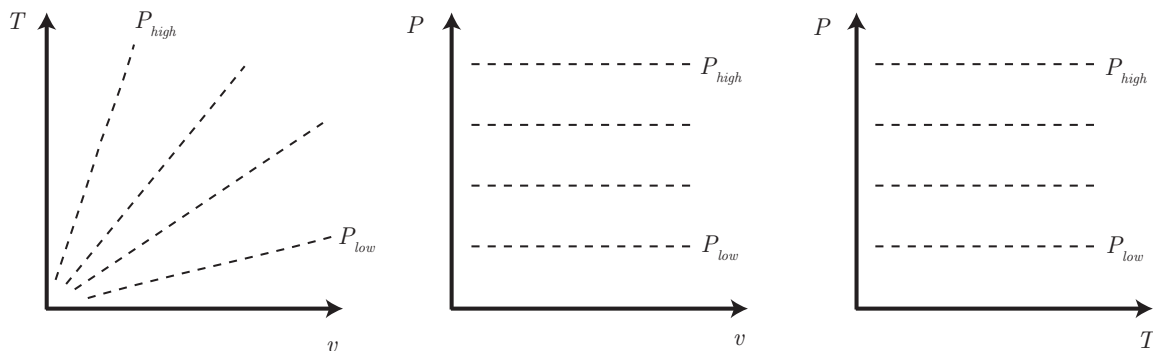

Figure 2.15: Isobars for an ideal gas in $T - v$, $P - v$, and $P - T$ planes.

- isotherms

- Consider curves in the $T - v$ plane on which T is constant. Thus, for the ideal gas, we have

$$T = \text{constant}. \quad (2.28)$$

These are straight horizontal lines in the $T - v$ plane.

- Consider curves in the $P - v$ plane on which T is a constant. Thus, for the ideal gas, we have

$$P = (RT) \frac{1}{v}. \quad (2.29)$$

These are *hyperbolas* in the $P - v$ plane.

- Consider curves in the $P - T$ plane on which T is a constant. Thus, for the ideal gas, we have

$$T = \text{constant}. \quad (2.30)$$

These are straight vertical lines in the $P - T$ plane.

Isotherms in various planes are shown in Fig. 2.16.

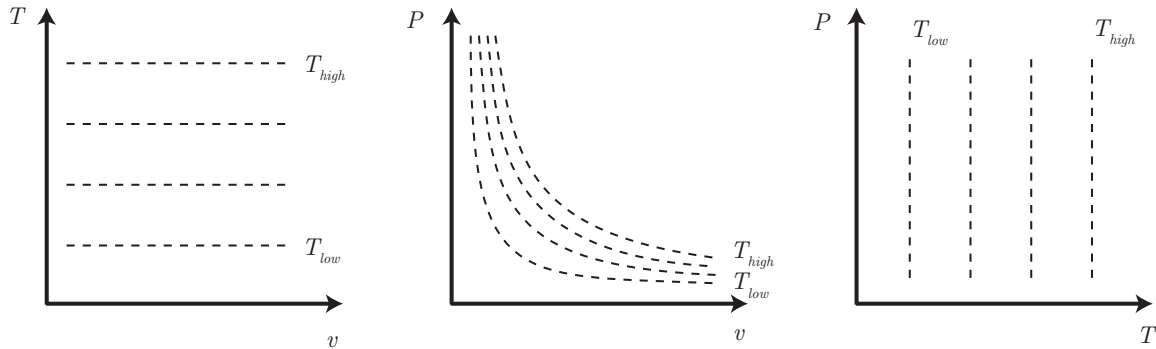

Figure 2.16: Isotherms for an ideal gas in $T - v$, $P - v$, and $P - T$ planes.

- isochores

- Consider curves in the $T - v$ plane on which v is constant. Thus, for the ideal gas, we have

$$v = \text{constant.} \quad (2.31)$$

These are straight vertical lines in the $T - v$ plane.

- Consider curves in the $P - v$ plane on which v is a constant. Thus, for the ideal gas, we have

$$v = \text{constant.} \quad (2.32)$$

These are straight vertical lines in the $P - v$ plane.

- Consider curves in the $P - T$ plane on which v is a constant. Thus, for the ideal gas, we have

$$P = \underbrace{\left(\frac{R}{v}\right)}_{\text{constant}} T. \quad (2.33)$$

These are straight lines in the $P - T$ plane with slope R/v . Because $R > 0$ and $v > 0$, the slope is always positive. For large v , the slope is shallow. For small v , the slope is steep.

Isochores in various planes are shown in Fig. 2.17.

Example 2.3

Given air in a cylinder with stops and a frictionless piston with area $A = 0.2 \text{ m}^2$, stop height of 1 m, and total height of 2 m, at initial state $P_1 = 200 \text{ kPa}$ and $T_1 = 500 \text{ }^\circ\text{C}$ with cooling, find

- the temperature when the piston reaches the stops, and
- the pressure if the cooling continues to $T = 20 \text{ }^\circ\text{C}$.

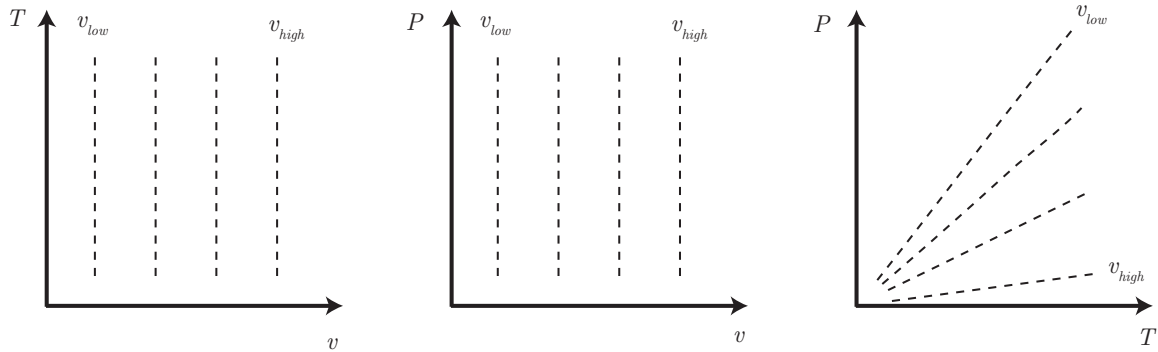

Figure 2.17: Isochores for an ideal gas in $T - v$, $P - v$, and $P - T$ planes.

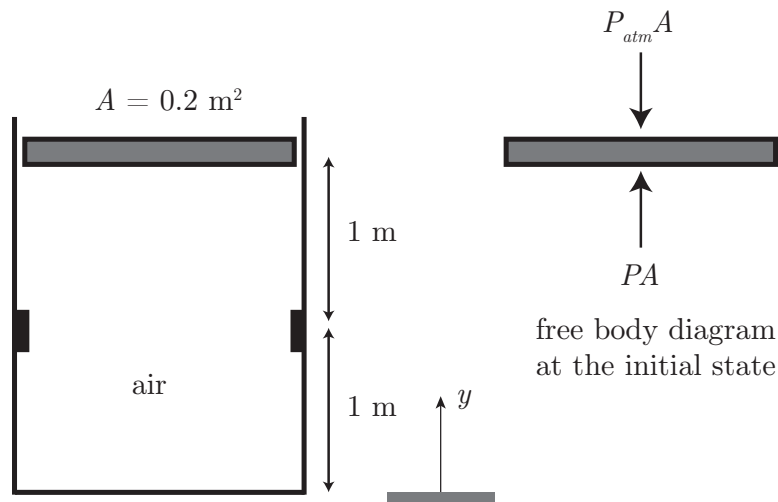

Figure 2.18: Sketch for example problem of cooling air.

The initial state along with a free body diagram is sketched in Fig. 2.18. We have three distinct states:

- state 1: initial state
- state 2: piston reaches the stops
- state 3: final state, where $T = 20^\circ\text{C}$.

At the initial state, the total volume is

$$V_1 = A((1 \text{ m}) + (1 \text{ m})) = (0.2 \text{ m}^2)(2 \text{ m}) = 0.4 \text{ m}^3. \quad (2.34)$$

We also know that $P_1 = 200 \text{ kPa}$. For use of the ideal gas law, we must use absolute temperature. So

$$T_1 = 500 + 273.15 = 773.15 \text{ K}. \quad (2.35)$$

Now, use the ideal gas law to get v_1 :

$$v_1 = \frac{RT_1}{P_1} = \frac{\left(0.287 \frac{\text{kJ}}{\text{kg K}}\right) (773.15 \text{ K})}{200 \text{ kPa}} = 1.10947 \frac{\text{m}^3}{\text{kg}}. \quad (2.36)$$

Let us check the units:

$$\frac{\text{kJ}}{\text{kg K}} \frac{\text{K}}{\text{kPa}} \frac{\text{kPa kN m}}{\frac{\text{kN}^2}{\text{m}^2}} \frac{\text{m}}{\text{kJ}} = \frac{\text{m}^3}{\text{kg}}.$$

As long as we employ kJ for energy and kPa for pressure, we will have few problems with units.

Now, the mass of the air, m , is constant in this problem. Because we have V_1 and v_1 , we can get m :

$$m = \frac{V_1}{v_1} = \frac{0.4 \text{ m}^3}{1.10947 \frac{\text{m}^3}{\text{kg}}} = 0.360532 \text{ kg}. \quad (2.37)$$

We write Newton's second law for the piston, which we take to have mass m_p :

$$\underbrace{m_p \frac{d^2 y}{dt^2}}_{\sim 0} = PA - P_{atm} A. \quad (2.38)$$

Here we have assumed the piston has not yet reached the stops, which will induce a force as well when encountered. In a standard assumption in thermodynamics, we neglect the inertia term, $m_p d^2 y / dt^2$, as small. This could be because either the piston mass m_p is small or the acceleration $d^2 y / dt^2$ is small, or both could be small. Neglecting inertia, we find the piston to be in a force balance giving $P_{atm} A = PA$, giving $P_{atm} = P$. So our atmosphere must be at $P_{atm} = 200 \text{ kPa}$. As the air cools, its temperature will go down. Because $Pv = RT$, as temperature goes down with constant P , we expect the volume to decrease. Just when the piston hits the stops, the stops still exert no force on the piston, so

$$P_2 = P_1 = 200 \text{ kPa}. \quad (2.39)$$

Now

$$V_2 = A(1 \text{ m}) = (0.2 \text{ m}^2)(1 \text{ m}) = 0.2 \text{ m}^3. \quad (2.40)$$

So

$$v_2 = \frac{V_2}{m} = \frac{0.2 \text{ m}^3}{0.360532 \text{ kg}} = 0.554735 \frac{\text{m}^3}{\text{kg}}. \quad (2.41)$$

Use the ideal gas law to get T_2 :

$$T_2 = \frac{P_2 v_2}{R} = \frac{(200 \text{ kPa}) \left(0.554735 \frac{\text{m}^3}{\text{kg}}\right)}{0.287 \frac{\text{kJ}}{\text{kg K}}} = \boxed{386.575 \text{ K}}. \quad (2.42)$$

Now, after the piston reaches the stops, the volume is constant. So the process from 2 to 3 is isochoric, and

$$V_3 = V_2 = 0.2 \text{ m}^3. \quad (2.43)$$

Thus

$$v_3 = v_2 = 0.554735 \frac{\text{m}^3}{\text{kg}}. \quad (2.44)$$

So

$$P_3 = \frac{RT_3}{v_3} = \frac{\left(0.287 \frac{\text{kJ}}{\text{kg K}}\right) (20 + 273.15 \text{ K})}{0.554735 \frac{\text{m}^3}{\text{kg}}} = \boxed{151.665 \text{ kPa}}. \quad (2.45)$$

We generate Table 2.1 to summarize the problem. It is usually useful to include sketches of the process in the various thermodynamic planes. This process is sketched in each of the relevant planes in Fig. 2.19.

Table 2.1: Numerical values for ideal gas cooling example

| variable | units | state 1 | state 2 | state 3 |
|----------|--------------------------------|---------|----------|----------|
| T | K | 773.15 | 386.575 | 293.15 |
| P | kPa | 200 | 200 | 151.665 |
| v | $\frac{\text{m}^3}{\text{kg}}$ | 1.10947 | 0.554735 | 0.554735 |
| V | m^3 | 0.4 | 0.2 | 0.2 |

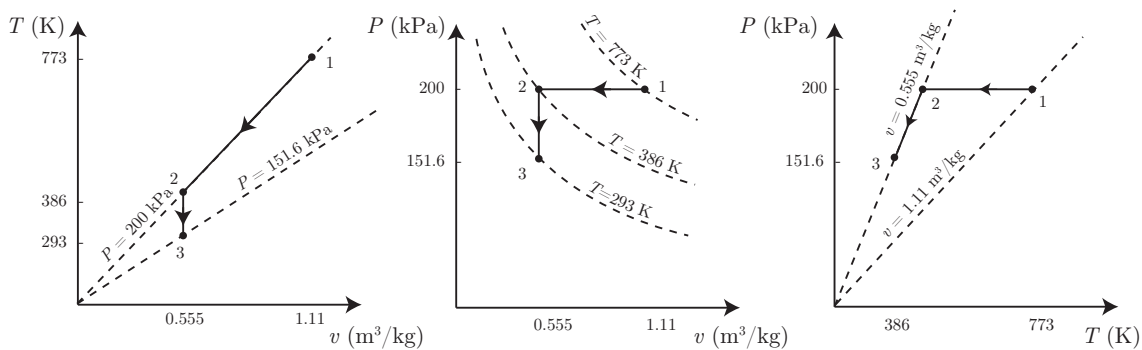
Figure 2.19: Sketch of $T - v$, $P - v$, and $P - T$ planes for air-cooling example problem.

2.4.2 Non-ideal thermal equations of state

The ideal gas law is not a good predictor of the $P - v - T$ behavior of gases when

- the gas has high enough density that molecular interaction forces become large and the molecules occupy a significant portion of the volume; this happens near the vapor dome typically, or
- the temperature is high enough to induce molecular dissociation (e.g. $\text{N}_2 + \text{N}_2 \rightleftharpoons 2\text{N} + \text{N}_2$).

One alternative is a corrected thermal equation of state.

2.4.2.1 van der Waals

For the *van der Waals*¹⁰ equation of state, that will be studied in more detail in Ch. 9.6, one has

$$P = \frac{RT}{v - b} - \frac{a}{v^2}, \quad (2.46)$$

¹⁰J. D. van der Waals, 1873, *Over de Continuïteit van den Gas -en Vloeistoestand*, Ph.D. Dissertation, U. Leiden; see also J. D. van der Waals, 1910, Nobel Lecture.

with

$$a = \frac{27 R^2 T_c^2}{64 P_c}, \quad b = \frac{1 R T_c}{8 P_c}. \quad (2.47)$$

A depiction of van der Waals is given in Fig. 2.20.



Figure 2.20: Johannes Diderik van der Waals (1837-1923), Dutch physicist and Nobel laureate who developed a corrected state equation. Image from https://en.wikipedia.org/wiki/Johannes_Diderik_van_der_Waals.

2.4.2.2 Redlich-Kwong

For the *Redlich-Kwong*¹¹ equation of state, one has

$$P = \frac{RT}{v - b} - \frac{a}{v(v + b)\sqrt{T}}, \quad (2.48)$$

with

$$a = (0.42748) \frac{R^2 T_c^{5/2}}{P_c}, \quad b = (0.08664) \frac{R T_c}{P_c}. \quad (2.49)$$

2.4.3 Compressibility factor

In some cases, more detail is needed to capture the behavior of the gas, especially near the vapor dome. Another commonly used approach to capturing this behavior is to define the

- COMPRESSIBILITY FACTOR: the deviation from ideality of a gas as measured by

$$Z = \frac{Pv}{RT}. \quad (2.50)$$

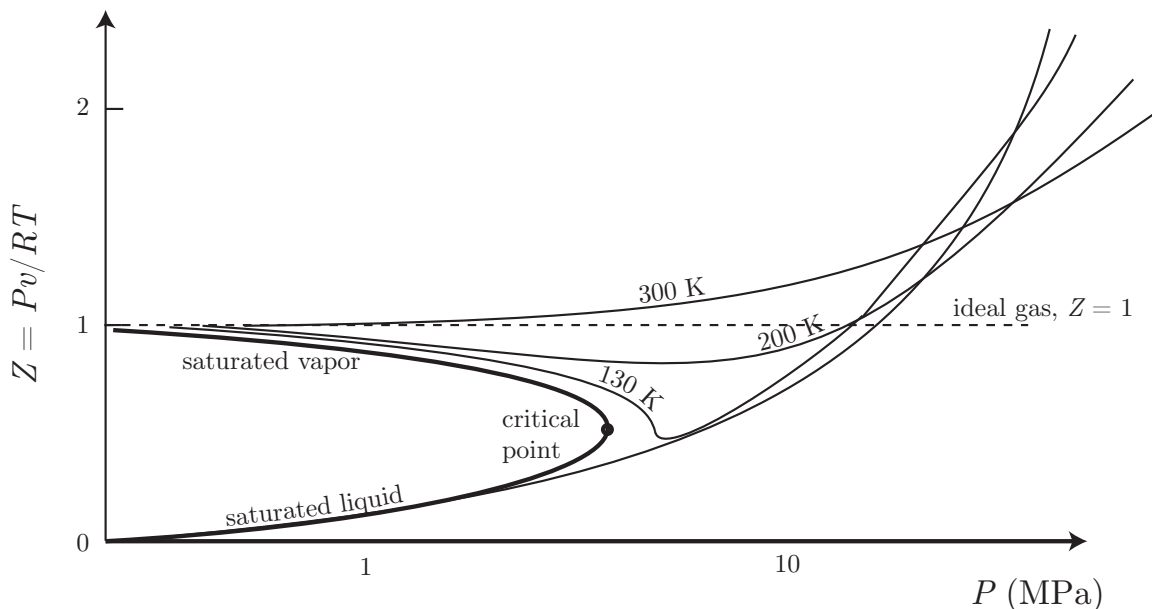

Figure 2.21: Sketch of compressibility chart for N_2 .

For ideal gases, $Pv = RT$, so $Z = 1$. Experiments show the behavior of real gases, and this can be presented in graphical form, as shown for N_2 in Fig. 2.21. Note

- for all T , $Z \rightarrow 1$ as $P \rightarrow 0$. Thus, one has ideal gas behavior at low pressure.
- for $T > 300$ K, $Z \sim 1$ for $P < 10$ MPa.
- Hold at $P = 4$ MPa and decrease temperature from 300 K; we see Z decrease below unity. Now

$$Z = \frac{Pv}{RT} = \frac{P}{\rho RT}, \quad \rho = \frac{P}{ZRT}. \quad (2.51)$$

Because $Z < 1$, the density ρ is higher than we would find for an ideal gas with $Z = 1$. Thus, in this region, there is an attractive force between molecules.

- For $P > 30$ MPa, we find $Z > 1$. Thus, a repulsive force exists in this regime. The forces are complicated.

Note that generalized compressibility charts have been developed for general gases. These are based on the so-called reduced pressures and temperatures, P_r and T_r , where

$$P_r = \frac{P}{P_c}, \quad T_r = \frac{T}{T_c}. \quad (2.52)$$

¹¹O. Redlich and J. N. S. Kwong, 1949, "On the thermodynamics of solutions. V. an equation of state. fugacities of gaseous solutions," *Chemical Reviews*, 44(1): 233-244.

The reduced pressure and temperature are dimensionless. Values with the c subscript are the critical constants for the individual gases. Appendix D of BS gives generalized compressibility charts.

2.4.4 Tabular thermal equations of state

Often equations are too inaccurate for engineering purposes. This is generally because we may be interested in behavior under a vapor dome. Consider that the surface for steam is well represented by that shown in Fig. 2.22.

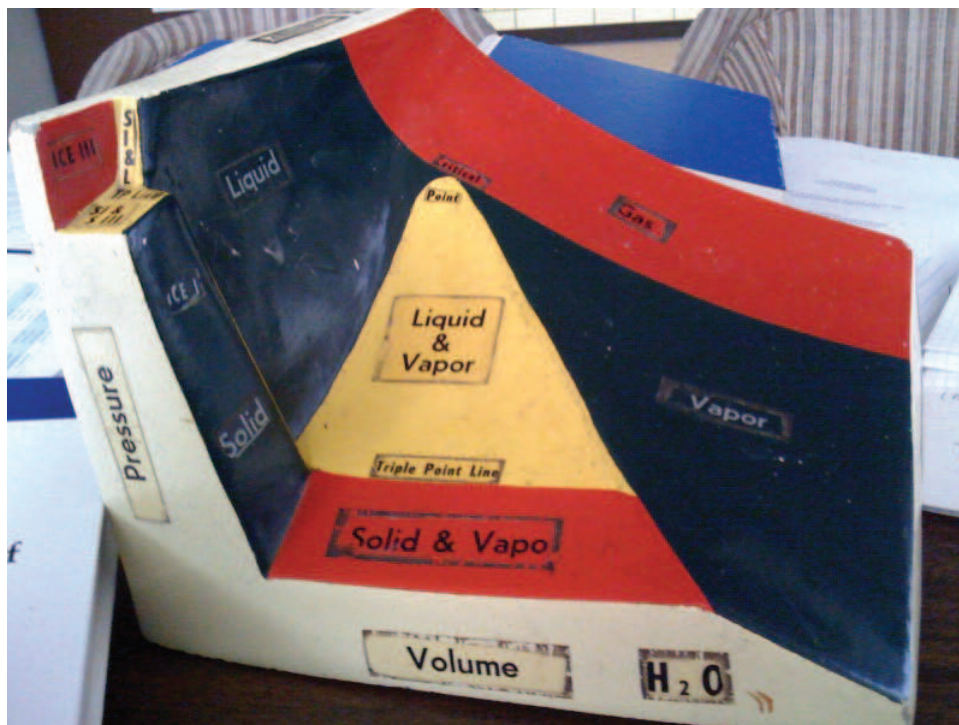

Figure 2.22: $P - v - T$ surface for H_2O , showing solid, liquid, and vapor phases.

In such cases, one should use tables to find a third property, given two independent properties. We can say that the thermal equation of state is actually embodied in the tabular data.

We lay down some rules of thumb for this class:

- If steam, use the tables.
- If air or most other gases, use the ideal gas law, but check if the pressure is high or the properties are near to the vapor dome, in which case use compressibility charts or non-ideal state equations.

Let us look at how the tables are organized.

2.4.4.1 Saturated liquid-vapor water, temperature tables

For water, the most important table is the saturated steam table. One should go to such tables first. If the water is a two-phase mixture, tables of this type must be used as the equation of state. Recall, *for two-phase mixtures, pressure and temperature are not independent thermodynamic variables*. Two properties still determine the state, but quality x is now important. So for two-phase mixtures we allow

- $T = T(v, x)$,
- $P = P(v, x)$, or
- $v = v(T, x)$,

for example. But $P \neq P(T, v)$ in contrast to ideal gases. or any superheated vapor.

Consider the structure of saturation tables, as shown in Table 2.2, extracted from BS's Table B.1.1. Data from the steam tables is sketched in Fig. 2.23. We have the notation:

| Temp. °C | Press. kPa | Specific Volume, $\frac{\text{m}^3}{\text{kg}}$ | | |
|-------------|---------------|---|-------------------|---------------------|
| | | Sat. Liquid v_f | Evap. v_{fg} | Sat. Vapor v_g |
| 0.01 | 0.6113 | 0.001000 | 206.131 | 206.132 |
| 5 | 0.8721 | 0.001000 | 147.117 | 147.118 |
| 10 | 1.2276 | 0.001000 | 106.376 | 106.377 |
| 15 | 1.705 | 0.001001 | 77.924 | 77.925 |
| ⋮ | ⋮ | ⋮ | ⋮ | ⋮ |
| 35 | 5.628 | 0.001006 | 25.2148 | 25.2158 |
| 40 | 7.384 | 0.001008 | 19.5219 | 19.5229 |
| ⋮ | ⋮ | ⋮ | ⋮ | ⋮ |
| 374.1 | 22089 | 0.003155 | 0 | 0.00315 |

Table 2.2: Saturated liquid-vapor water tables, temperature entry, from BS, Table B.1.1.

- f : saturated liquid,
- g : saturated vapor,
- v_f : specific volume of saturated liquid, and
- v_g : specific volume of saturated vapor.

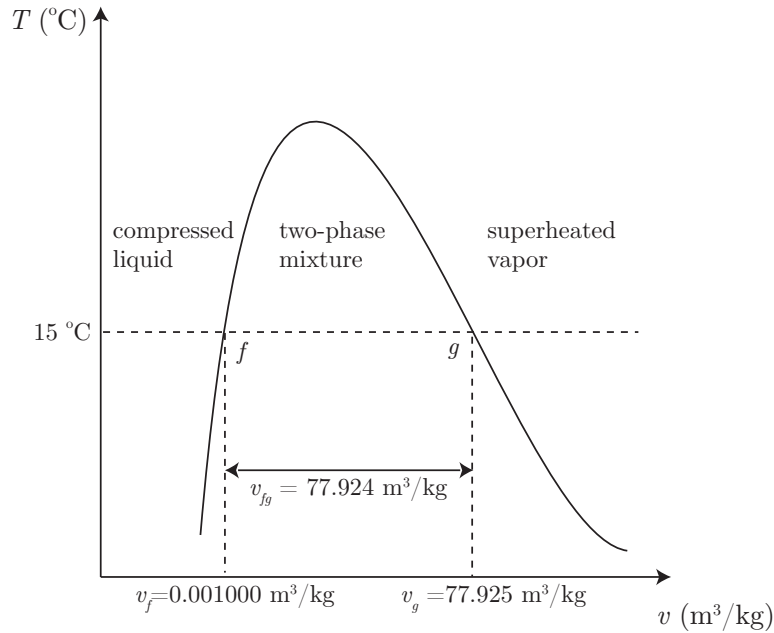

Figure 2.23: Vapor dome for H_2O with data for v_f , v_g , and v_{fg} at $T = 15^\circ\text{C}$.

Note for liquid-vapor mixtures, this table begins at the triple point temperature 0.01°C and ends at the critical temperature 374.1°C . At $P = P_c$ and $T = T_c$, we have $v_f = v_g$. Note that

- $v_f \simeq$ constant, and
- v_g decreases with increasing T .

We define v_{fg} as

$$v_{fg} \equiv v_g - v_f. \quad (2.53)$$

Recall the quality x is

$$x = \frac{m_{\text{vap}}}{m_{\text{total}}}.$$

Consider a mass of fluid m in total volume V . We will take

$$V = V_{\text{liq}} + V_{\text{vap}}, \quad (2.54)$$

$$m = m_{\text{liq}} + m_{\text{vap}}. \quad (2.55)$$

Now, use the definition of specific volume and operate on Eq. (2.54) to get

$$\overbrace{mv}^V = \overbrace{m_{liq}v_f}^{V_{liq}} + \overbrace{m_{vap}v_g}^{V_{vap}}, \quad (2.56)$$

$$v = \frac{m_{liq}}{m}v_f + \frac{m_{vap}}{m}v_g, \quad (2.57)$$

$$v = \frac{m - m_{vap}}{m}v_f + \frac{m_{vap}}{m}v_g, \quad (2.58)$$

$$v = (1 - x)v_f + xv_g, \quad (2.59)$$

$$v = v_f + x \underbrace{(v_g - v_f)}_{=v_{fg}}. \quad (2.60)$$

We get the final important results:

$$\boxed{v = v_f + xv_{fg}}, \quad (2.61)$$

$$\boxed{x = \frac{v - v_f}{v_{fg}}}. \quad (2.62)$$

What was presented in this section was a type of *mixture theory*. This particular theory describes a so-called *Amagat mixture*. Amagat mixtures have components that share a common temperature T and pressure P , but each component has its own volume, a so-called *partial volume*. The key equation for Amagat mixtures is Eq. (2.54), $V = V_{liq} + V_{vap}$. Here the partial volumes are V_{liq} and V_{vap} . It describes two-phase gas-liquid mixtures well; it also most useful for mixtures with two materials with distinct densities and clear boundaries between materials. In contrast, mixtures of gases are often better described by a so-called *Dalton mixture* theory. Components of a Dalton mixture share a common temperature T and volume V , but each component has its own pressure, a so-called *partial pressure*. The key equation for a two-component Dalton mixture is that the total pressure is the sum of the partial pressures, e.g. $P = P_A + P_B$. Such mixtures do not possess distinct boundaries to distinguish components. Dalton mixture theory is the foundation of theories to describe gas phase chemistry. In general the theory of mixtures is difficult subject, and there is no general agreement on what mathematical model best describes general systems. Depictions of Amagat and Dalton are given in Fig. 2.24.

2.4.4.2 Saturated liquid-vapor water, pressure tables

Sometimes we are given the pressure of the mixture, and a saturation table based on the pressure is more useful. An example of a portion of such a table is shown in Table 2.3.

Example 2.4

Given a vessel with $V = 0.4 \text{ m}^3$ filled with $m = 2 \text{ kg}$ of H_2O at $P = 600 \text{ kPa}$, find

- the volume and mass of liquid, and

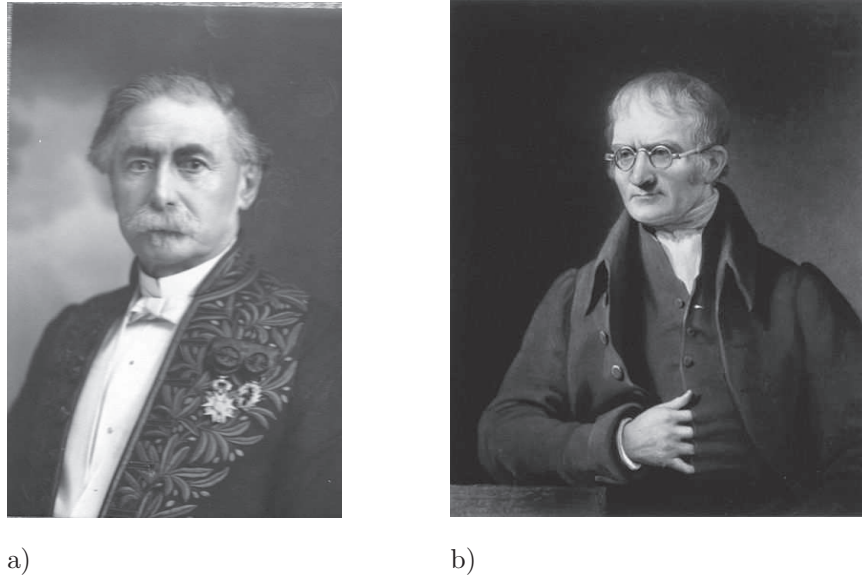

Figure 2.24: a) Émile Hilaire Amagat (1841-1915), French physicist. Image from https://en.wikipedia.org/wiki/Émile_Amagat, b) John Dalton (1766-1844), English scientist who developed atomic theory and studied color blindness. Image from https://en.wikipedia.org/wiki/John_Dalton.

- the volume and mass of vapor.

The problem is sketched in Fig. 2.25. While the problem statement suggests we have a two-phase

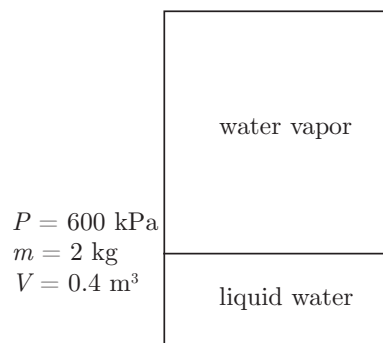

Figure 2.25: Schematic for liquid-vapor mixture example problem.

mixture, that is not certain until one examines the tables. First, calculate the specific volume of the water:

$$v = \frac{V}{m} = \frac{0.4 \text{ m}^3}{2 \text{ kg}} = 0.2 \frac{\text{m}^3}{\text{kg}}. \quad (2.63)$$

Next go to the saturated water tables with pressure entry to see if the water is a two-phase mixture.

| Press. kPa | Temp. °C | Specific Volume, $\frac{\text{m}^3}{\text{kg}}$ | | |
|---------------|-------------|---|-------------------|---------------------|
| | | Sat. Liquid v_f | Evap. v_{fg} | Sat. Vapor v_g |
| 0.6113 | 0.01 | 0.001000 | 206.131 | 206.132 |
| 1.0 | 6.98 | 0.001000 | 129.20702 | 129.20802 |
| 1.5 | 13.03 | 0.001001 | 87.97913 | 87.98013 |
| 2.0 | 17.50 | 0.001001 | 67.00285 | 67.00385 |
| ⋮ | ⋮ | ⋮ | ⋮ | ⋮ |
| 22089 | 374.1 | 0.003155 | 0 | 0.00315 |

Table 2.3: Saturated water tables, pressure entry from BS, Table B.1.2.

We find at $P = 600$ kPa that

$$v_f = 0.001101 \frac{\text{m}^3}{\text{kg}}, \quad v_g = 0.31567 \frac{\text{m}^3}{\text{kg}}. \quad (2.64)$$

Now, for our mixture, we see that $v_f < v < v_g$, so we have a two-phase mixture. Now, apply Eq. (2.62) to find the quality.

$$x = \frac{v - v_f}{v_{fg}} = \frac{v - v_f}{v_g - v_f} = \frac{0.2 \frac{\text{m}^3}{\text{kg}} - 0.001101 \frac{\text{m}^3}{\text{kg}}}{0.31567 \frac{\text{m}^3}{\text{kg}} - 0.001101 \frac{\text{m}^3}{\text{kg}}} = 0.632291. \quad (2.65)$$

Now, from Eq. (2.1), we have $x = m_{vap}/m_{total}$, so

$$m_{vap} = xm_{tot} = 0.632291(2 \text{ kg}) = \boxed{1.26458 \text{ kg}}. \quad (2.66)$$

Now, for the liquid mass we have

$$m_{liq} = m_{total} - m_{vap} = (2 \text{ kg}) - (1.26458 \text{ kg}) = \boxed{0.735419 \text{ kg}}. \quad (2.67)$$

Most of the mass is vapor, but the fraction that is liquid is large.

Now, let us calculate the volumes.

$$V_{vap} = m_{vap}v_g = (1.26458 \text{ kg}) \left(0.31567 \frac{\text{m}^3}{\text{kg}} \right) = \boxed{0.39919 \text{ m}^3}, \quad (2.68)$$

$$V_{liq} = m_{liq}v_f = (0.735419 \text{ kg}) \left(0.001101 \frac{\text{m}^3}{\text{kg}} \right) = \boxed{0.000809696 \text{ m}^3}. \quad (2.69)$$

The volume is nearly entirely vapor.

| Temp. °C | v $\frac{\text{m}^3}{\text{kg}}$ | u $\frac{\text{kJ}}{\text{kg}}$ | h $\frac{\text{kJ}}{\text{kg}}$ | s $\frac{\text{kJ}}{\text{kg K}}$ |
|--|---------------------------------------|--------------------------------------|--------------------------------------|--|
| $P = 10 \text{ kPa (45.81 } ^\circ\text{C)}$ | | | | |
| Sat. | 14.67355 | 2437.89 | 2584.63 | 8.1501 |
| 50 | 14.86920 | 2443.87 | 2592.56 | 8.1749 |
| 100 | 17.19561 | 2515.50 | 2687.46 | 8.4479 |
| 150 | 19.51251 | 2587.86 | 2782.99 | 8.6881 |
| ⋮ | ⋮ | ⋮ | ⋮ | ⋮ |

Table 2.4: Superheated water tables, from BS, Table B.1.3.

2.4.4.3 Superheated water tables

The superheat regime is topologically similar to an ideal gas. For a superheated vapor, the quality x is meaningless, and we can once again allow pressure and temperature to be independent. Thus, we can have $v = v(T, P)$. And the tables are in fact structured to give $v(T, P)$ most directly. An example of a portion of such a table is shown in Table 2.4. This portion of the superheated tables focuses on a single isobar, $P = 10 \text{ kPa}$. At that pressure, the saturation temperature is $45.81 \text{ }^\circ\text{C}$, indicated in parentheses. As long as $T > 45.81 \text{ }^\circ\text{C}$, we can use this table for $P = 10 \text{ kPa}$ water. And for various values of $T > 45.81 \text{ }^\circ\text{C}$, we find other properties, such as specific volume v , and properties we have not yet focused on, internal energy u , enthalpy h , and entropy s .

2.4.4.4 Compressed liquid water tables

Liquids truly have properties that vary with both T and P . To capture such variation, we can use compressed liquid tables as an equation of state. An example for water is given in Table 2.5. If compressed liquid tables do not exist, it is usually safe enough to assume properties are those for $x = 0$ saturated liquid at the appropriate temperature.

2.4.4.5 Saturated water, solid-vapor

Other types of saturation can exist. For example, below the triple point temperature, one can have solid water in equilibrium with water vapor. The process where ice transforms directly to water vapor is known as *sublimation*. Saturation tables for ice-vapor equilibrium exist as well. For example, consider the structure of saturation tables, as shown in Table 2.6, extracted from BS's Table B.1.5.

| Temp. °C | v $\frac{\text{m}^3}{\text{kg}}$ | u $\frac{\text{kJ}}{\text{kg}}$ | h $\frac{\text{kJ}}{\text{kg}}$ | s $\frac{\text{kJ}}{\text{kg K}}$ |
|--|---------------------------------------|--------------------------------------|--------------------------------------|--|
| $P = 500 \text{ kPa (151.86 } ^\circ\text{C)}$ | | | | |
| Sat. | 0.001093 | 639.66 | 640.21 | 1.8606 |
| 0.01 | 0.000999 | 0.01 | 0.51 | 0.0000 |
| 20 | 0.001002 | 83.91 | 84.41 | 0.2965 |
| 40 | 0.001008 | 167.47 | 167.98 | 0.5722 |
| ⋮ | ⋮ | ⋮ | ⋮ | ⋮ |

Table 2.5: Compressed liquid water tables, from BS, Table B.1.4.

| Temp. °C | Press. kPa | Specific Volume, $\frac{\text{m}^3}{\text{kg}}$ | | |
|-------------|---------------|---|-------------------|---------------------|
| | | Sat. Solid v_i | Evap. v_{ig} | Sat. Vapor v_g |
| 0.01 | 0.6113 | 0.0010908 | 206.152 | 206.153 |
| 0 | 0.6108 | 0.0010908 | 206.314 | 206.315 |
| -2 | 0.5177 | 0.0010905 | 241.662 | 241.663 |
| -4 | 0.4376 | 0.0010901 | 283.798 | 283.799 |
| ⋮ | ⋮ | ⋮ | ⋮ | ⋮ |

Table 2.6: Saturated solid-vapor water tables, temperature entry, from BS, Table B.1.5.

2.4.4.6 Tables for other materials

For many materials similar tables exist, e.g., ammonia, NH_3 . Consider the ammonia saturation tables, as shown in Table 2.7, extracted from BS's Table B.2.1. One also has tables for

| Temp. °C | Press. kPa | Specific Volume, $\frac{\text{m}^3}{\text{kg}}$ | | |
|-------------|---------------|---|-------------------|---------------------|
| | | Sat. Liquid v_f | Evap. v_{fg} | Sat. Vapor v_g |
| -50 | 40.9 | 0.001424 | 2.62557 | 2.62700 |
| -45 | 54.5 | 0.001437 | 2.00489 | 2.00632 |
| -40 | 71.7 | 0.001450 | 1.55111 | 1.55256 |
| -35 | 93.2 | 0.001463 | 1.21466 | 1.21613 |
| ⋮ | ⋮ | ⋮ | ⋮ | ⋮ |
| 132.3 | 11333.2 | 0.004255 | 0 | 0.004255 |

Table 2.7: Saturated liquid-vapor ammonia tables, temperature entry, from BS, Table B.2.1.

superheated ammonia vapor. An example of a portion of such a table is shown in Table 2.8. Other tables in BS, include those for carbon dioxide, CO_2 , a modern refrigerant, R-410a,¹²

| Temp. °C | v $\frac{\text{m}^3}{\text{kg}}$ | u $\frac{\text{kJ}}{\text{kg}}$ | h $\frac{\text{kJ}}{\text{kg}}$ | s $\frac{\text{kJ}}{\text{kg K}}$ |
|---|---------------------------------------|--------------------------------------|--------------------------------------|--|
| $P = 50 \text{ kPa } (-46.53 \text{ }^\circ\text{C})$ | | | | |
| Sat. | 2.1752 | 1269.6 | 1378.3 | 6.0839 |
| -30 | 2.3448 | 1296.2 | 1413.4 | 6.2333 |
| -20 | 2.4463 | 1312.3 | 1434.6 | 6.3187 |
| -10 | 2.5471 | 1328.4 | 1455.7 | 6.4006 |
| ⋮ | ⋮ | ⋮ | ⋮ | ⋮ |

Table 2.8: Superheated ammonia tables, from BS, Table B.2.2.

another common refrigerant, R-134a,¹³ diatomic nitrogen, N_2 , and methane, CH_4 .

2.4.4.7 Linear interpolation of tabular data

- Interpolation is often required when exact values are not tabulated.

¹²a common cooling fluid invented in 1991, a near-azeotropic mixture of difluoromethane and pentafluoroethane.

¹³a cooling fluid that became common in the 1990s, 1,1,1,2-tetrafluoroethane.

- In this course we will primarily use *linear interpolations*.
- Use extrapolations only if there is no other choice.
- Occasionally double interpolations will be necessary.

2.4.4.7.1 Single interpolation The most common interpolation is the single interpolation of variables. We give an example here.

Example 2.5

Given water at $T = 36.7^\circ\text{C}$, with $v = 10\text{ m}^3/\text{kg}$, find the pressure and the quality if a two-phase mixture.

A wise first step is to go to the saturated tables. We check Table B.1.1 from BS and find there are no values at $T = 36.7^\circ\text{C}$. So we must create our own personal steam table values at this temperature, just to determine if where we are on the thermodynamic surface. We list the important part of the saturated water liquid-vapor tables in Table 2.9.

| Temp. $^\circ\text{C}$ | Press. kPa | Specific Volume, $\frac{\text{m}^3}{\text{kg}}$ | | |
|---------------------------|---------------|---|-------------------|---------------------|
| | | Sat. Liquid v_f | Evap. v_{fg} | Sat. Vapor v_g |
| \vdots | \vdots | \vdots | \vdots | \vdots |
| 35 | 5.628 | 0.001006 | 25.2148 | 25.2158 |
| 36.7 | ? | ? | ? | ? |
| 40 | 7.384 | 0.001008 | 19.5219 | 19.5229 |
| \vdots | \vdots | \vdots | \vdots | \vdots |

Table 2.9: Relevant portion of saturated liquid-vapor water tables, temperature entry, from BS, Table B.1.1.

We seek to get appropriate values for P , v_f , v_{fg} , and v_g at $T = 36.7^\circ\text{C}$. Let us find P first. The essence of linear interpolation is to fit known data to a straight line, then use the formula of that line to predict intermediate values of variables of interest. We know values of P at $T = 35^\circ\text{C}$ and $T = 40^\circ\text{C}$. In fact we have two points: $(T_1, P_1) = (35^\circ\text{C}, 5.628\text{ kPa})$, and $(T_2, P_2) = (40^\circ\text{C}, 7.384\text{ kPa})$. This lets us fit a line using the familiar *point-slope* formula:

$$P - P_1 = \underbrace{\left(\frac{P_2 - P_1}{T_2 - T_1}\right)}_{\text{slope}}(T - T_1). \quad (2.70)$$

We could have used the other point. Note when $T = T_1$, that $P = P_1$. Also, when $T = T_2$, $P = P_2$.

Substituting numbers, we get

$$P = \left(\frac{(7.384 \text{ kPa}) - (5.628 \text{ kPa})}{(40 \text{ }^\circ\text{C}) - (35 \text{ }^\circ\text{C})} \right) (T - (35 \text{ }^\circ\text{C})) + (5.628 \text{ kPa}), \quad (2.71)$$

$$= \left(0.3512 \frac{\text{kPa}}{^\circ\text{C}} \right) (T - (35 \text{ }^\circ\text{C})) + (5.628 \text{ kPa}), \quad (2.72)$$

$$= \left(0.3512 \frac{\text{kPa}}{^\circ\text{C}} \right) ((36.7 \text{ }^\circ\text{C}) - (35 \text{ }^\circ\text{C})) + (5.628 \text{ kPa}), \quad (2.73)$$

$$= \boxed{6.225 \text{ kPa.}} \quad (2.74)$$

The interpolation is sketched in Fig. 2.26.

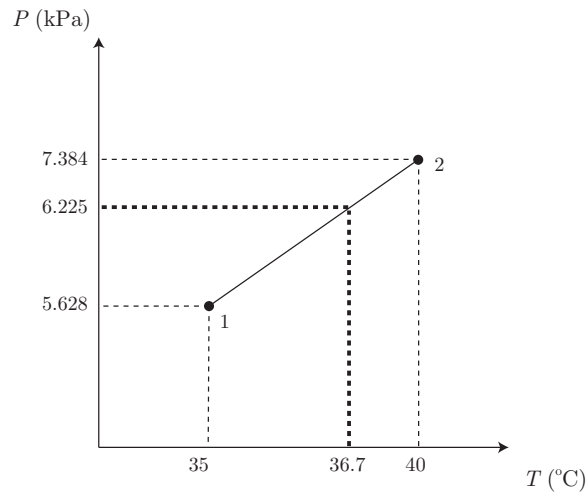

Figure 2.26: Sketch of linear interpolation to find P when $T = 36.7 \text{ }^\circ\text{C}$, $v = 10 \text{ m}^3/\text{kg}$ for water.

Now, we need to interpolate for v_f and v_g as well. Let us apply the same technique. For v_f , we have

$$v_f - \left(0.001006 \frac{\text{m}^3}{\text{kg}} \right) = \left(\frac{\left(0.001008 \frac{\text{m}^3}{\text{kg}} \right) - \left(0.001006 \frac{\text{m}^3}{\text{kg}} \right)}{(40 \text{ }^\circ\text{C}) - (35 \text{ }^\circ\text{C})} \right) (T - (35 \text{ }^\circ\text{C})). \quad (2.75)$$

When $T = 36.7 \text{ }^\circ\text{C}$, we get

$$v_f = 0.00100668 \frac{\text{m}^3}{\text{kg}}. \quad (2.76)$$

For v_g , we get

$$v_g - \left(25.2158 \frac{\text{m}^3}{\text{kg}} \right) = \left(\frac{\left(19.5229 \frac{\text{m}^3}{\text{kg}} \right) - \left(25.2158 \frac{\text{m}^3}{\text{kg}} \right)}{(40 \text{ }^\circ\text{C}) - (35 \text{ }^\circ\text{C})} \right) (T - (35 \text{ }^\circ\text{C})). \quad (2.77)$$

When $T = 36.7 \text{ }^\circ\text{C}$, we get

$$v_g = 23.2802 \frac{\text{m}^3}{\text{kg}}. \quad (2.78)$$

Knowing v_f and v_g , we do not need to interpolate for v_{fg} . We can simply use the definition:

$$v_{fg} = v_g - v_f = \left(23.2802 \frac{\text{m}^3}{\text{kg}}\right) - \left(0.00100668 \frac{\text{m}^3}{\text{kg}}\right) = 23.2792 \frac{\text{m}^3}{\text{kg}}. \quad (2.79)$$

Now, $v = 10 \text{ m}^3/\text{kg}$. Because at $T = 36.7^\circ\text{C}$, we have $v_f < v < v_g$, we have a two-phase mixture.

Let us get the quality. From Eq. (2.62), we have

$$x = \frac{v - v_f}{v_{fg}} = \frac{\left(10 \frac{\text{m}^3}{\text{kg}}\right) - \left(0.00100668 \frac{\text{m}^3}{\text{kg}}\right)}{23.2792 \frac{\text{m}^3}{\text{kg}}} = 0.429525. \quad (2.80)$$

Thus

$$x = \frac{m_{\text{vap}}}{m_{\text{tot}}} = 0.429525. \quad (2.81)$$

2.4.4.7.2 Double interpolation Sometimes, we need to do two linear interpolations. We call this *double interpolation*. Say we are given superheated water with v_o and T_o and we are asked to find P_o . But neither v_o nor T_o are listed in the tables. Then we need to do a multi-step procedure.

- Go to the tables and for the given T_o and v_o , estimate approximately the value of P_o by visual examination.
- For a nearby value of $P = P_1$, get a linear interpolation of the form $T = T(v, P_1)$. Use this to get $T_1 = T(v_o, P_1)$.
- For a different nearby value of $P = P_2$, get another linear interpolation of the form $T = T(v, P_2)$. Use this to get $T_2 = T(v_o, P_2)$. We now have two points (T_1, P_1) and (T_2, P_2) , both valid at $v = v_o$.
- Use the two points (T_1, P_1) , (T_2, P_2) to develop a third interpolation $P = P(T, v_o)$. Estimate P_o by $P_o = P(T_o, v_o)$.

Example 2.6

Consider $m = 1 \text{ kg}$ of H_2O initially at $T_1 = 110^\circ\text{C}$, $x_1 = 0.9$. The H_2O is heated until $T_2 = 200^\circ\text{C}$. As sketched in Fig. 2.27, the H_2O is confined in a piston-cylinder arrangement, where the piston is constrained by a linear spring with $dP/dv = 40 \text{ kPa}/\text{m}^3/\text{kg}$. At the initial state, the spring is unstretched. Find the final pressure.

While this problem seems straightforward, there are many challenges. Let us first consider what we know about the initial state. Because we have a numerical value for x_1 , we know state 1 is a two-phase mixture. From the tables, we find that

$$P_1 = 143.3 \text{ kPa}, \quad v_{f1} = 0.001052 \frac{\text{m}^3}{\text{kg}}, \quad v_{g1} = 1.2101 \frac{\text{m}^3}{\text{kg}}, \quad v_{fg1} = 1.20909 \frac{\text{m}^3}{\text{kg}}. \quad (2.82)$$

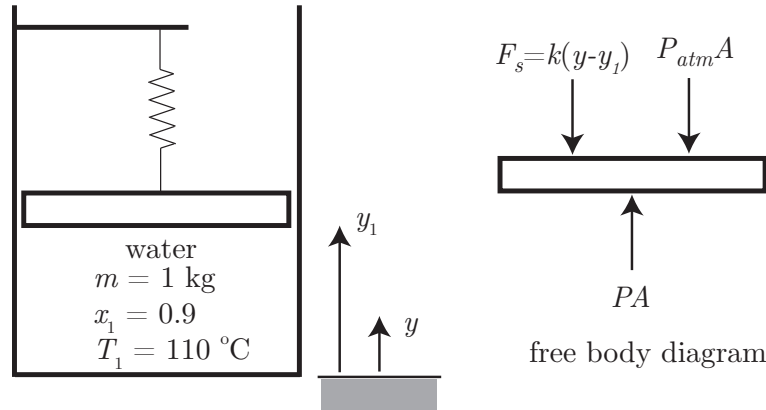

Figure 2.27: Sketch of piston-cylinder arrangement.

We can then calculate v_1 for the mixture:

$$v_1 = v_{f1} + x_1 v_{fg1} = \left(0.001052 \frac{\text{m}^3}{\text{kg}}\right) + (0.9) \left(1.20909 \frac{\text{m}^3}{\text{kg}}\right) = 1.08923 \frac{\text{m}^3}{\text{kg}}. \quad (2.83)$$

We now know everything we need about state 1.

At state 2, we only know one intensive thermodynamic property, the temperature, $T_2 = 200 \text{ }^\circ\text{C}$.

- To get a second, and thus define the final state, we will need to bring in information about the process.

Now, we will need to consider a force balance on the piston. Newton's second law for the piston says

$$m_{piston} \frac{d^2 y}{dt^2} = \sum F_y. \quad (2.84)$$

From our free body diagram, we note three forces:

- force due to the interior pressure from the water,
- force due to the exterior pressure from the atmosphere,
- force due to the linear spring, that we call $F_s = k(y - y_1)$ where k is the spring constant, y is the position of the piston, and y_1 is the initial position of the piston. Note that $F_s = 0$ when $y = y_1$.

We write this as

$$m_{piston} \frac{d^2 y}{dt^2} = PA - P_{atm} A - k(y - y_1). \quad (2.85)$$

Now, in classical thermodynamics, we make the assumption that the inertia of the piston is so small that we can neglect its effect. We are really requiring that a force balance exist for all time. Thus, even though the piston will move, and perhaps accelerate, its acceleration will be so small that it can be neglected relative to the forces in play. We thus take

$$\left| m_{piston} \frac{d^2 y}{dt^2} \right| \ll |F_s|, |P_{atm} A|, |PA|. \quad (2.86)$$

With this assumption, we have

$$0 \simeq PA - P_{atm} A - k(y - y_1). \quad (2.87)$$

Solve for P , the water pressure, to get

$$P = P_{atm} + \frac{k}{A}(y - y_1). \quad (2.88)$$

Now, $V = Ay$ and $V_1 = Ay_1$, so we can say

$$P = P_{atm} + \frac{k}{A^2}(V - V_1). \quad (2.89)$$

Let us use the fact that $V = mv$ and $V_1 = mv_1$ to rewrite as

$$P = P_{atm} + \frac{km}{A^2}(v - v_1). \quad (2.90)$$

This equation is highlighted because it provides an algebraic relationship between two intensive thermodynamic properties, P and v , and such a tactic will be useful for many future problems. Using numbers from our problem, with $dP/dv = km/A^2$, we can say

$$P = (143.3 \text{ kPa}) + \left(40 \frac{\text{kPa}}{\frac{\text{m}^3}{\text{kg}}}\right) \left(v - \left(1.08923 \frac{\text{m}^3}{\text{kg}}\right)\right), \quad (2.91)$$

$$P = \underbrace{(99.7308 \text{ kPa}) + \left(40 \frac{\text{kPa}}{\frac{\text{m}^3}{\text{kg}}}\right)}_{\text{linear spring rule}} v. \quad (2.92)$$

Now, at state 1, we have $V = V_1$ and $P = P_1 = 143.3 \text{ kPa}$, so we must have $P_{atm} = 143.3 \text{ kPa}$ for this problem.

Let us now consider the possibilities for state 2. We are constrained to be on the line in $P - v$ space given by our force balance, Eq. (2.92). We are also constrained to be on the $T = 200 \text{ }^\circ\text{C}$ isotherm, that is also a curve in $P - v$ space. So let us consider the $P - v$ plane, as sketched in Fig. 2.28. The

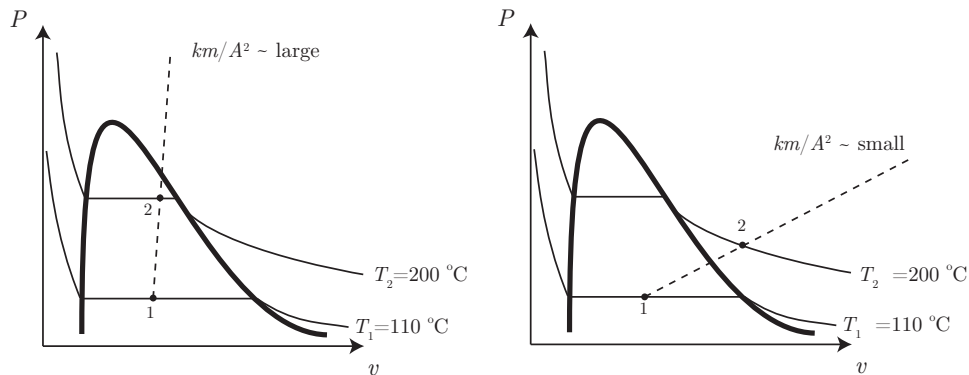

Figure 2.28: Sketch of $P - v$ plane for piston-cylinder-linear spring problem for water.

isotherms for $T_1 = 110 \text{ }^\circ\text{C}$ and $T_2 = 200 \text{ }^\circ\text{C}$ are set in both parts of Fig. 2.28. Because both T_1 and T_2 are well below T_c , both isotherms pierce the vapor dome. Our final state has a line in $P - v$ space from the force balance intersecting the state 2 isotherm. There are two distinct possibilities for the final state:

- for a stiff spring, i.e. large km/A^2 , our line will intersect the isotherm within the vapor dome, or

- for a loose spring, i.e. small km/A^2 , our line will intersect the isotherm in the superheated vapor region.

Let us consider the first possibility: state 2 is under the vapor dome. If that is the case, then the tables tell us that $P_2 = 1553.8$ kPa. At this pressure, Eq. (2.92) gives us $v = (1553.8 - 99.7308)/40 = 36.3517$ m³/kg. However, at this pressure $v_g = 0.12736$ m³/kg. Because we just found $v > v_g$, our assumption that the final state was under the dome must be incorrect!

Therefore, let us go to the more difficult case posed by the second possibility: state 2 is a superheated vapor. In general the intersection of the straight line with the isotherm is difficult. We can use linearization to assist us. Let us choose a small region of the tables, and locally fit the 200 °C isotherm to a straight line. This will give us a second *independent* equation in $P - v$ space. We will then solve two equations in two unknowns for the final state.

Our initial pressure, $P_1 = 143.3$ kPa lies between 100 kPa and 200 kPa. We have values from the superheat tables at these pressures for v at 200 °C. So, we approximate the isotherm by the line

$$P - (100 \text{ kPa}) = \frac{(200 \text{ kPa}) - (100 \text{ kPa})}{\left(1.08034 \frac{\text{m}^3}{\text{kg}}\right) - \left(2.17226 \frac{\text{m}^3}{\text{kg}}\right)} \left(v - \left(2.17226 \frac{\text{m}^3}{\text{kg}}\right)\right). \quad (2.93)$$

$$P = \underbrace{(298.939 \text{ kPa}) - \left(91.5818 \frac{\text{kPa}}{\frac{\text{m}^3}{\text{kg}}}\right)}_{\text{linear approximation of isotherm from tabular thermal EOS}} v. \quad (2.94)$$

linear approximation of isotherm from tabular thermal EOS

We simultaneously solve the two linear equations, Eqs. (2.92, 2.94), and get the unique solution

$$\boxed{P_2 = 160.289 \text{ kPa}}, \quad v_2 = 1.151395 \frac{\text{m}^3}{\text{kg}}. \quad (2.95)$$

Because we found $100 \text{ kPa} < P_2 = 160.289 \text{ kPa} < 200 \text{ kPa}$, we made a good assumption on the final pressure, and our interpolation values from the tables are acceptable. Lastly, we sketch the process in the $T - v$ and $P - T$ planes in Fig. 2.29.

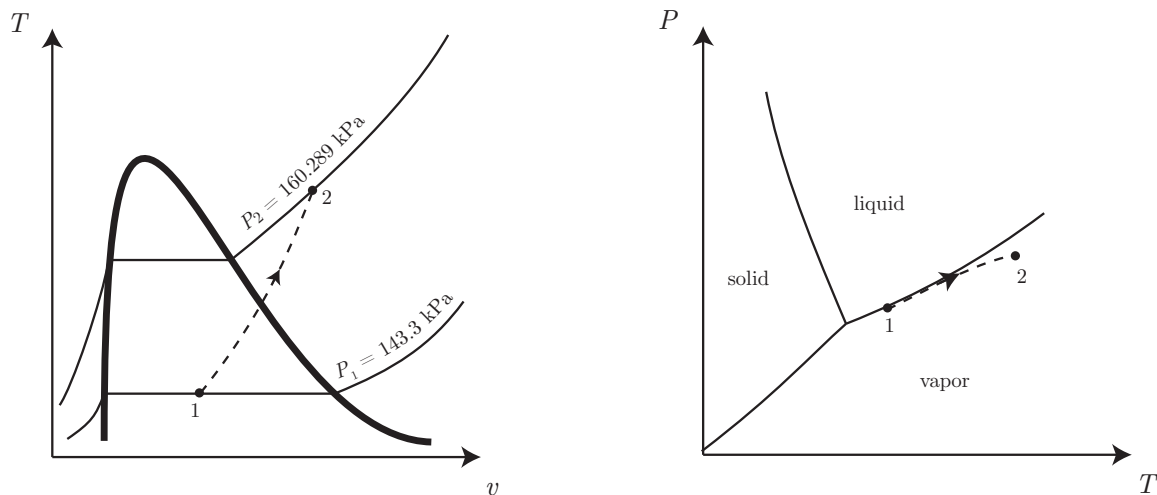

Figure 2.29: Sketch of $T - v$ and $P - T$ planes for piston-cylinder-linear spring problem for water.

Chapter 3

The first law of thermodynamics

Read BS, Chapter 3

Recall in the example problem of Chapter 1, p. 24, we saw that mechanical energy was conserved for a mass falling under the sole influence of a gravitational force. We took the mechanical energy to be the sum of the kinetic and potential energy of the system. But when we included a drag force, we found that mechanical energy was no longer conserved, but in fact dissipated with time. There was considerable discussion in the 17th and 18th centuries that pitted advocates of a so-called *vis viva* (“force of life,” a type of kinetic energy) against those who argued for the primacy of momentum conservation. Leibniz led the *vis viva* camp, and Newton and Descartes led the momentum camp. Both ultimately are equivalent formulations when analyzed carefully.

In this chapter, we will expand our notion of energy and in so doing recover a new conservation principle. This new principle, not known to Newton, is the first law of thermodynamics. It takes many equivalent forms, and relies at a minimum on the introduction of a new type of energy, thermal energy, that is necessary to conserve the total energy.

Thermal energy is actually a macro-scale representation of micro-scale mechanical energy. Recall that at the micro-scale, molecules are in random motion. This random motion has kinetic energy associated with it. But we cannot hope to keep track of it all for each individual particle. So we surrender knowledge of the micro-scale motions, and allow the temperature to be a measure of the average micro-scale kinetic energy. We can also take the historical approach and develop the principle of energy conservation without further appeal to micro-scale arguments. Let us begin that approach here.

3.1 Mathematical preliminaries: exact differentials

We first review some notions from calculus of many variables. Recall in thermodynamics, we are often concerned with functions of two independent variables, e.g. $P = P(v, T)$, as is found in an equation of state. Here, let us consider $z = z(x, y)$ for a general analysis.

3.1.1 Partial derivatives

Recall if $z = z(x, y)$, then the *partial derivative* of z can be taken if one of the variables is held constant.

Example 3.1

If $z = \sqrt{x^2 + y^2}$, find the partial of z with respect to x and then with respect to y .

First let us get the derivative with respect to x . We take

$$\left. \frac{\partial z}{\partial x} \right|_y = \frac{x}{\sqrt{x^2 + y^2}}. \quad (3.1)$$

Next for the derivative with respect to y , we have

$$\left. \frac{\partial z}{\partial y} \right|_x = \frac{y}{\sqrt{x^2 + y^2}}. \quad (3.2)$$

3.1.2 Total derivative

If $z = z(x, y)$, for every x and y , we have a z . Here, we can think of z as a *scalar field*. The field here is the (x, y) plane, and z varies over this field. We also have the *total differential*

$$dz = \left. \frac{\partial z}{\partial x} \right|_y dx + \left. \frac{\partial z}{\partial y} \right|_x dy. \quad (3.3)$$

On a particular path C in the $x - y$ plane along which we know $y = y(x)$, we also have the total derivative

$$\frac{dz}{dx} = \left. \frac{\partial z}{\partial x} \right|_y + \left. \frac{\partial z}{\partial y} \right|_x \frac{dy}{dx}. \quad (3.4)$$

Now, we can integrate dz along a variety of paths C in the $x - y$ plane. Two paths from z_1 to z_2 are shown in Fig. 3.1. Integrating Eq. (3.3), we get

$$\int_1^2 dz = \int_C \left(\left. \frac{\partial z}{\partial x} \right|_y dx + \left. \frac{\partial z}{\partial y} \right|_x dy \right). \quad (3.5)$$

Now, because $z = z(x, y)$, it will not matter which path we choose. The integral is said to be *path-independent*.

Conversely, if we were given

$$dz = M(x, y) dx + N(x, y) dy, \quad (3.6)$$

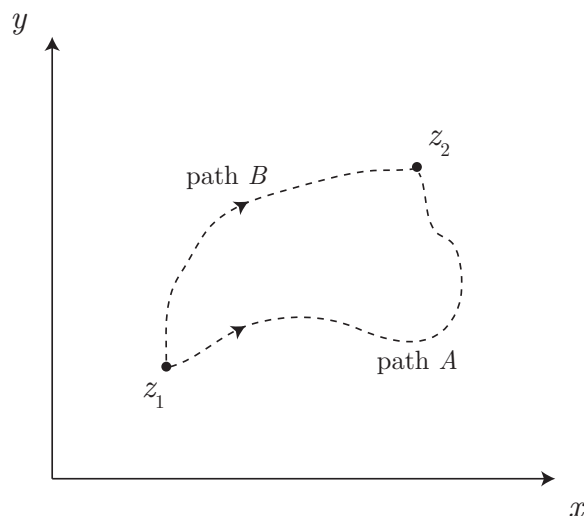

Figure 3.1: Sketch of two paths from z_1 to z_2 in the $x - y$ plane.

the associated integrals are path-independent iff $z(x, y)$ can be found by solving.

$$M = \left. \frac{\partial z}{\partial x} \right|_y, \quad N = \left. \frac{\partial z}{\partial y} \right|_x. \quad (3.7)$$

One easy way to check this is to form the following two partial derivatives of Eqs. (3.7):

$$\left. \frac{\partial M}{\partial y} \right|_x = \frac{\partial^2 z}{\partial y \partial x}, \quad \left. \frac{\partial N}{\partial x} \right|_y = \frac{\partial^2 z}{\partial x \partial y}. \quad (3.8)$$

Now, if $z(x, y)$ and all its partial derivatives are continuous and differentiable, it is easy to prove the order of differentiation does not matter: $\partial^2 z / \partial x \partial y = \partial^2 z / \partial y \partial x$. Thus, if $z = z(x, y)$, we must insist that

$$\left. \frac{\partial M}{\partial y} \right|_x = \left. \frac{\partial N}{\partial x} \right|_y. \quad (3.9)$$

We define the following:

- EXACT DIFFERENTIAL: a differential that yields a path-independent integral.

Example 3.2

If $dz = x dx + y dy$, is dz exact?

Here,

$$M = \left. \frac{\partial z}{\partial x} \right|_y = x. \quad (3.10)$$

Thus

$$z = \frac{1}{2}x^2 + f(y). \quad (3.11)$$

Thus

$$\left. \frac{\partial z}{\partial y} \right|_x = \frac{df}{dy} = y. \quad (3.12)$$

Thus

$$f(y) = \frac{1}{2}y^2 + C, \quad (3.13)$$

and

$$z(x, y) = \frac{1}{2}(x^2 + y^2) + C. \quad (3.14)$$

Examine a difference in z :

$$z_2 - z_1 = \frac{1}{2}(x_2^2 - x_1^2 + y_2^2 - y_1^2). \quad (3.15)$$

Note the constant C drops out and that the difference in z only depends on the end points and not the path between points 1 and 2. Here, dz is exact.

Note also that

$$\left. \frac{\partial M}{\partial y} \right|_x = 0, \quad \left. \frac{\partial N}{\partial x} \right|_y = 0, \quad (3.16)$$

thus, our condition for exactness, Eq. (3.9), is satisfied.

Example 3.3

If $dz = y dx - x dy$, is dz exact?

Here,

$$M = \left. \frac{\partial z}{\partial x} \right|_y = y. \quad (3.17)$$

Thus

$$z = yx + f(y). \quad (3.18)$$

So

$$\left. \frac{\partial z}{\partial y} \right|_x = x + \frac{df}{dy} = -x. \quad (3.19)$$

Thus

$$\frac{df}{dy} = -2x. \quad (3.20)$$

But functions of y cannot be functions of x . Therefore, we have generated nonsense. We cannot find $z(x, y)$! Thus, z is not a state variable, and dz is inexact. We give a new notation for such differentials: δz and we say more accurately for this inexact differential

$$\delta z = y dx - x dy. \quad (3.21)$$

If we choose a path, we can still find differences in z . Let us examine the integral of z along two paths, illustrated in Fig. 3.2.

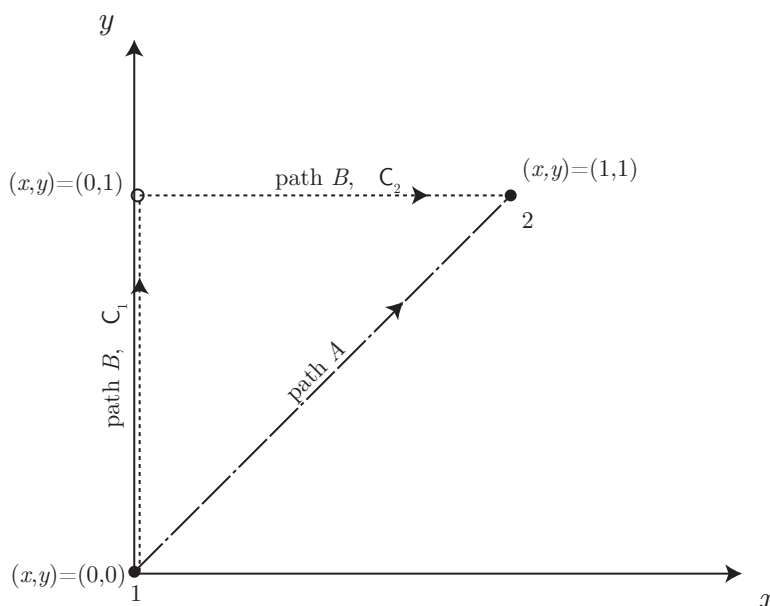
Figure 3.2: Sketch of two paths in the $x - y$ plane.

- *Path A*: Integrate from $(x, y) = (0, 0)$ to $(x, y) = (1, 1)$ along the path $x = y$ and find $z_2 - z_1$.

On path A, $x = y$ and $dx = dy$. So eliminate y to get

$$\delta z = x dx - x dx = 0. \quad (3.22)$$

Thus, $\delta z = 0$, and $z = C$ after integrations. Thus $z_2 = z_1 = C$, and $z_2 - z_1 = 0$.

- *Path B*: Integrate from $(x, y) = (0, 0)$ to $(x, y) = (1, 1)$ along the path given first by the y -axis from 0 to 1, then by the line $y = 1$ from $x = 0$ to $x = 1$ and find $z_2 - z_1$.

We have

$$\int_1^2 \delta z = \int_{C_1} y dx - x dy + \int_{C_2} y dx - x dy. \quad (3.23)$$

On C_1 , we have $x = 0$, and $dx = 0$. On C_2 , we have $y = 1$ and $dy = 0$. So we get

$$\int_1^2 \delta z = \int_{C_1} y(0) - (0) dy + \int_{C_2} (1) dx - x(0) = \int_0^1 dx. \quad (3.24)$$

Thus

$$z_2 - z_1 = 1. \quad (3.25)$$

We chose a different path, and found a different difference in z .

Note also that

$$\left. \frac{\partial M}{\partial y} \right|_x = 1, \quad \left. \frac{\partial N}{\partial x} \right|_y = -1; \quad (3.26)$$

thus, our condition for exactness, Eq. (3.9), is *not* satisfied.

As an aside, we note that the notions of exact differentials and path-independence are sometimes presented in other terms, especially in mathematics texts. We review some of these alternates here. We begin by restricting attention to a function of one variable, $z(x)$, and take that

$$\frac{dz}{dx} = z'(x), \quad (3.27)$$

where $z'(x)$ is simply a known function of x . We can thus say

$$dz = z'(x) dx. \quad (3.28)$$

We can integrate both sides to get

$$\int_1^2 dz = \int_1^2 z'(x) dx. \quad (3.29)$$

Now at point 1, we have $x = x_1$ and $z = z_1$. Similarly, at point 2, we have $x = x_2$ and $z = z_2$. So

$$z_2 - z_1 = \int_{x_1}^{x_2} \frac{dz}{dx} dx, \quad (3.30)$$

$$z(x_2) - z(x_1) = \int_{x_1}^{x_2} \frac{dz}{dx} dx. \quad (3.31)$$

Equation (3.31) is the so-called *fundamental theorem of calculus*.

For functions of two independent variables, $z(x, y)$, such as is common in thermodynamics, we can perform an equivalent analysis. Let us begin with Eq. (3.3), which is the two-dimensional analog of Eq. (3.28):

$$dz = \left. \frac{\partial z}{\partial x} \right|_y dx + \left. \frac{\partial z}{\partial y} \right|_x dy. \quad (3.32)$$

Recalling that the superscript $(\cdot)^T$ denotes the transpose, take now the two-dimensional column vector $d\mathbf{x}$ and two-dimensional row vector $(\nabla z)^T$ as

$$d\mathbf{x} = \begin{pmatrix} dx \\ dy \end{pmatrix}, \quad (\nabla z)^T = \left(\left. \frac{\partial z}{\partial x} \right|_y \quad \left. \frac{\partial z}{\partial y} \right|_x \right), \quad (3.33)$$

so that we can rewrite Eq. (3.32) in vector form as

$$dz = \left(\left. \frac{\partial z}{\partial x} \right|_y \quad \left. \frac{\partial z}{\partial y} \right|_x \right) \begin{pmatrix} dx \\ dy \end{pmatrix} = (\nabla z)^T \cdot d\mathbf{x}. \quad (3.34)$$

Let us now integrate both sides on a contour C , which is a specified path in the $x - y$ plane:

$$\int_C dz = \int_C (\nabla z)^T \cdot d\mathbf{x}, \quad (3.35)$$

$$z(x_2, y_2) - z(x_1, y_1) = \int_C (\nabla z)^T \cdot d\mathbf{x}. \quad (3.36)$$

The end points of \mathbf{C} are $(x_1, y_1)^T$ and $(x_2, y_2)^T$. Here Eq. (3.36) is the two-dimensional equivalent of Eq. (3.31) and is sometimes called the *fundamental theorem for line integrals*. Because we have required $z = z(x, y)$, the integral on any \mathbf{C} is path-independent.

If the curve \mathbf{C} is a closed contour, then its beginning point is its end point. Thus $(x_1, y_1)^T = (x_2, y_2)^T$, and so $z(x_1, y_1) = z(x_2, y_2)$. We denote closed contour integrals by $\oint_{\mathbf{C}}$. In this case Eq. (3.36) reduces to

$$0 = \oint_{\mathbf{C}} (\nabla z)^T \cdot d\mathbf{x}. \quad (3.37)$$

We may confirm this by recalling Stokes' theorem:

$$\oint_{\mathbf{C}} \mathbf{f}^T \cdot d\mathbf{x} = \iint_S (\nabla \times \mathbf{f})^T \cdot \mathbf{n} \, dS. \quad (3.38)$$

Here \mathbf{f} is any vector field. For a vector field, each component of the vector may vary over the field. For example, for a two-dimensional vector field, $\mathbf{f}(\mathbf{x})$, we can expect to have

$$\mathbf{f} = \begin{pmatrix} f_x \\ f_y \end{pmatrix}, \quad \mathbf{x} = \begin{pmatrix} x \\ y \end{pmatrix}, \quad (3.39)$$

and then

$$f_x = f_x(x, y), \quad f_y = f_y(x, y). \quad (3.40)$$

We also may recall from calculus that iff \mathbf{f} has the special property that it is the gradient of a scalar field, $\mathbf{f} = \nabla z$, then the field \mathbf{f} is curl-free; that is

$$\nabla \times \mathbf{f} = \nabla \times \nabla z = \mathbf{0}. \quad (3.41)$$

Thus we have for this special case of Stokes' theorem that

$$\oint_{\mathbf{C}} (\nabla z)^T \cdot d\mathbf{x} = \iint_S \mathbf{0}^T \cdot \mathbf{n} \, dS = 0, \quad (3.42)$$

thus confirming Eq. (3.37).

Example 3.4

If $z = z(x, y)$, verify ∇z is curl-free.

We have

$$\nabla z = \begin{pmatrix} \frac{\partial z}{\partial x} \Big|_y \\ \frac{\partial z}{\partial y} \Big|_x \end{pmatrix}. \quad (3.43)$$

And we find

$$\nabla \times \nabla z = \begin{vmatrix} \mathbf{i} & \mathbf{j} & \mathbf{k} \\ \frac{\partial}{\partial x} & \frac{\partial}{\partial y} & 0 \\ \frac{\partial z}{\partial x}\Big|_y & \frac{\partial z}{\partial y}\Big|_x & 0 \end{vmatrix} = \left(\frac{\partial^2 z}{\partial x \partial y} - \frac{\partial^2 z}{\partial y \partial x} \right) \mathbf{k} = \mathbf{0}. \quad (3.44)$$

This holds for all $z(x, y)$ that are continuous and differentiable because under these conditions the operators $\partial/\partial x$ and $\partial/\partial y$ commute. For example, if $z = x^2 + xy^3$, we find

$$\frac{\partial z}{\partial x}\Big|_y = 2x + y^3, \quad \frac{\partial z}{\partial y}\Big|_x = 3xy^2. \quad (3.45)$$

We then see that

$$\frac{\partial^2 z}{\partial y \partial x} = 3y^2, \quad \frac{\partial^2 z}{\partial x \partial y} = 3y^2. \quad (3.46)$$

The two mixed partials are the same, despite the fact they were taken in different order.

Example 3.5

Consider the two-dimensional scalar field $z(\mathbf{x})$ defined by

$$z(\mathbf{x}) = z(x, y) = x^2 + y^2. \quad (3.47)$$

A contour plot of curves of constant z is given in Fig. 3.3. We see the magnitude z is zero at the

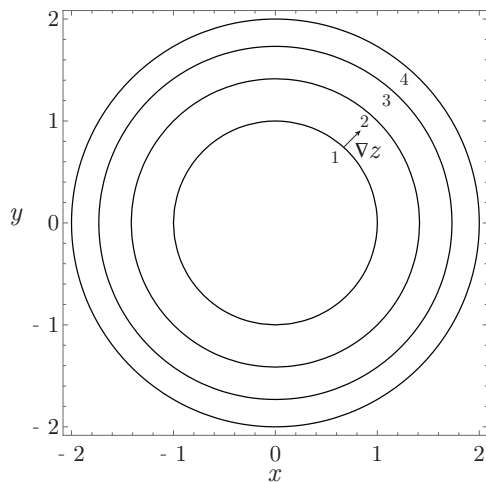

Figure 3.3: Scalar field for $z(x, y) = x^2 + y^2$.

origin. We also see that the gradient of z is

$$\nabla z = \frac{\partial}{\partial x}(x^2 + y^2)\mathbf{i} + \frac{\partial}{\partial y}(x^2 + y^2)\mathbf{j} = 2x\mathbf{i} + 2y\mathbf{j} = \begin{pmatrix} 2x \\ 2y \end{pmatrix}. \quad (3.48)$$

The gradient vector points away from the origin and is in the direction of most rapid increase of z . The gradient vector is normal to the contours of z .

Example 3.6

Consider the two-dimensional vector field $\mathbf{f}(\mathbf{x})$ defined by

$$f_x(x, y) = x, \quad f_y(x, y) = y. \quad (3.49)$$

A plot of the vector field is given in Fig. 3.4. We see the magnitude \mathbf{f} is zero at the origin. We also

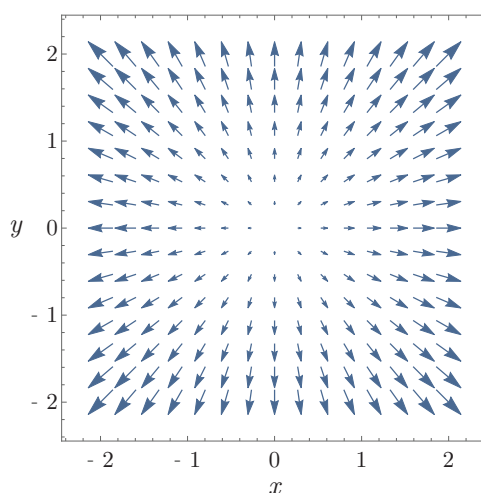

Figure 3.4: Vector field for $f_x = x$, $f_y = y$.

see that

$$\nabla \cdot \mathbf{f} = \frac{\partial f_x}{\partial x} + \frac{\partial f_y}{\partial y} = 1 + 1 = 2. \quad (3.50)$$

And we see that

$$\nabla \times \mathbf{f} = \begin{vmatrix} \mathbf{i} & \mathbf{j} & \mathbf{k} \\ \frac{\partial}{\partial x} & \frac{\partial}{\partial y} & 0 \\ x & y & 0 \end{vmatrix} = \mathbf{0}. \quad (3.51)$$

The vector field has a non-zero divergence, but is curl-free.

Example 3.7

Consider the two-dimensional vector field $\mathbf{f}(\mathbf{x})$ defined by

$$f_x(x, y) = -x + y, \quad f_y(x, y) = x + y. \quad (3.52)$$

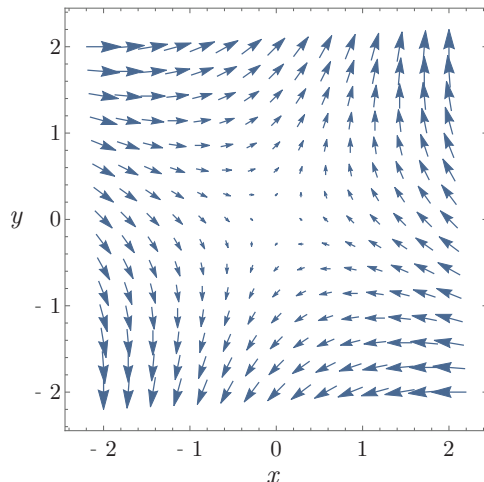

Figure 3.5: Vector field for $f_x = -x + y$, $f_y = x + y$.

A plot of the vector field is given in Fig. 3.5. We see the magnitude \mathbf{f} is zero at the origin. We also see that

$$\nabla \cdot \mathbf{f} = \frac{\partial f_x}{\partial x} + \frac{\partial f_y}{\partial y} = -1 + 1 = 0. \quad (3.53)$$

And we see that

$$\nabla \times \mathbf{f} = \begin{vmatrix} \mathbf{i} & \mathbf{j} & \mathbf{k} \\ \frac{\partial}{\partial x} & \frac{\partial}{\partial y} & 0 \\ -x + y & x + y & 0 \end{vmatrix} = \mathbf{0}. \quad (3.54)$$

The vector field is both divergence-free and curl-free.

Example 3.8

Examine the ideal gas law $Pv = RT$ in the context of exact differentials.

We have $P = RT/v$; thus, in terms of differentials, we can say

$$dP = \left. \frac{\partial P}{\partial v} \right|_T dv + \left. \frac{\partial P}{\partial T} \right|_v dT, \quad (3.55)$$

$$= -\frac{RT}{v^2} dv + \frac{R}{v} dT. \quad (3.56)$$

Now $RT/v^2 > 0$ and $R/v > 0$. Thus

- For an isothermal process, $dv > 0$ induces $dP < 0$; volume increase corresponds to pressure decrease.

- For an isochoric process, $dT > 0$ induces $dP > 0$; temperature increase corresponds to pressure increase.

Let us verify the condition for an exact differential holds. We should have

$$\frac{\partial}{\partial T} \left(-\frac{RT}{v^2} \right) = \frac{\partial}{\partial v} \left(\frac{R}{v} \right), \quad (3.57)$$

$$-\frac{R}{v^2} = -\frac{R}{v^2}. \quad (3.58)$$

The differential is exact, as it must be because we actually began with a path-independent state function.

3.2 Work

3.2.1 Definitions

From Newtonian mechanics, we know going from state 1 to state 2, that the work ${}_1W_2$ is done by a force moving through a distance. The word “work” was first used in this sense by the French mechanician Gaspard-Gustave Coriolis, depicted in Fig. 3.6. Work is defined as



Figure 3.6: Gaspard-Gustave Coriolis (1792-1843), French physicist who used to word “work” to characterize a force acting through a distance. Image from https://en.wikipedia.org/wiki/Gaspard-Gustave_Coriolis.

$${}_1W_2 = \int_1^2 \mathbf{F} \cdot d\mathbf{x}. \quad (3.59)$$

In differential form, we have

$$\delta W = \mathbf{F} \cdot d\mathbf{x}. \quad (3.60)$$

In one-dimensional systems, we have

$${}_1W_2 = \int_1^2 F dx, \quad (3.61)$$

$$\delta W = F dx. \quad (3.62)$$

Note that we have anticipated that the work differential is inexact. This is an important point, as work integrals will be *path-dependent*, and work will not be a state variable for a system. Here, \mathbf{F} is a three-dimensional force vector, \mathbf{x} is a three-dimensional distance vector, and \cdot is the dot product operator. Recall that the dot product of two vectors yields a scalar. The terms F and x are scalar equivalents valid for one-dimensional systems. The units of force are N, those of distance are m, so the units of work are N m, that have been defined as Joules (J).

Work is done by a system if the sole effect on the surroundings (i.e. everything external to the system) could be the raising of a weight. We take the following sign convention:

- + work done by the system,
- – work done on the system.

This sign convention is not universal. Many physicists use precisely the opposite convention. Probably the reason for this convention is that thermodynamics is a science that was invented by engineers in the nineteenth century. And those engineers wanted to produce work from steam engines. Systems doing work were viewed favorably and endowed with a positive sign.

We associate energy with the ability to do work. We define

- POWER: the time rate of doing work $= \delta W/dt$.
- SPECIFIC WORK: the work per unit mass $w = W/m$. Because work is path-dependent, the intensive quantity w is not a thermodynamic state variable.

3.2.2 Work for a simple compressible substance

Consider the scenario sketched in Fig. 3.7. In state 1, we have a material at pressure P confined in a cylinder of cross-sectional area A . The height of the piston in the cylinder is x . The pressure force of the material on the piston is just balanced by weights on top of the piston.

Now, remove one of the weights. We notice a motion of the piston to a new height $x + dx$. We let a long time elapse so the system comes to rest at its new equilibrium. We notice there is a new pressure in the chamber, $P + dP$ sufficient to balance the new weight force. Obviously work was done as a force acted through a distance. Let us calculate how much work was done. The differential work is given from Eq. (3.62) as

$$\delta W = F dx. \quad (3.63)$$

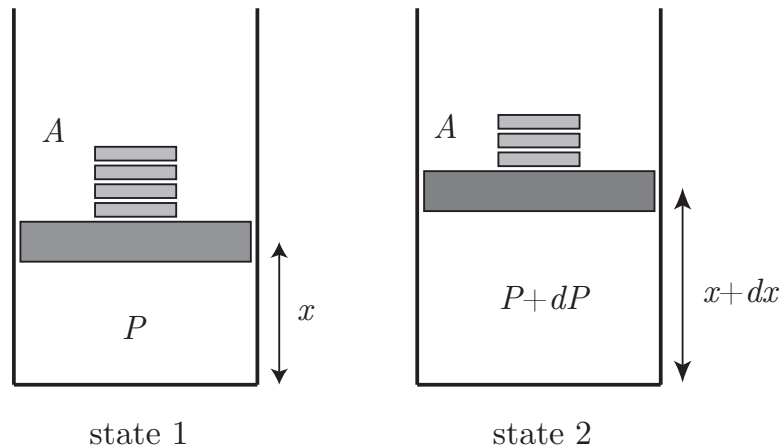

Figure 3.7: Sketch of piston-cylinder arrangement as work is done as the material expands when weights are removed.

Now, F varies during the process. At state 1, we have $F = PA$. At state 2, we have $F = (P + dP)A$. Let us approximate F by its average value:

$$F \sim \frac{1}{2}(PA + (P + dP)A) = PA + \frac{A}{2} dP. \quad (3.64)$$

So

$$\delta W = \left(PA + \frac{A}{2} dP \right) dx = PA dx + \frac{A}{2} \underbrace{dP dx}_{\sim 0}. \quad (3.65)$$

Let us only retain terms that are differential and neglect the square of differential terms, so

$$\delta W = PA dx. \quad (3.66)$$

Now, because $A dx = dV$, the differential volume, we get the important formula:

$$\boxed{\delta W = P dV.} \quad (3.67)$$

We can integrate this and get the equally important

$$\boxed{{}_1W_2 = \int_1^2 P dV.} \quad (3.68)$$

Note we employ the unusual notation ${}_1W_2$ to emphasize that the work depends on the path from state 1 to state 2. We are tempted to write the incorrect form $\int_1^2 \delta W = W_2 - W_1$, but this would imply the work is a state function, which it is not, as shown directly.

Example 3.9

Show that work is path-dependent.

We have $\delta W = P dV$. In terms of intensive variables, assuming path-independence, we would have

$$dw = P dv. \quad (3.69)$$

If w were a path-independent property, we could have $w = w(P, v)$, that would admit the exact

$$dw = \underbrace{\left. \frac{\partial w}{\partial v} \right|_P}_{=P} dv + \underbrace{\left. \frac{\partial w}{\partial P} \right|_v}_{=0} dP. \quad (3.70)$$

Our physics of $dw = P dv + 0 dP$ tells us by comparison that we would need

$$\left. \frac{\partial w}{\partial v} \right|_P = P, \quad \text{and} \quad \left. \frac{\partial w}{\partial P} \right|_v = 0. \quad (3.71)$$

Integrating the first gives

$$w = Pv + f(P). \quad (3.72)$$

Differentiating with respect to P gives

$$\left. \frac{\partial w}{\partial P} \right|_v = v + \frac{df(P)}{dP} = 0. \quad (3.73)$$

Thus

$$\frac{df(P)}{dP} = -v. \quad (3.74)$$

Functions of P cannot be functions of v if P and v are independent. Therefore dw is not exact, $w \neq w(P, v)$, and $\int_1^2 P dv$ is path-dependent.

We can also see the path-dependence of ${}_1W_2$ by realizing that ${}_1W_2 = \int_1^2 P dV$ represents the area under a curve in a $P - V$ diagram. Consider two paths, A and B from the same points 1 to 2 as depicted in the $P - V$ space of Fig. 3.8. The area under the curve defined by Path A is clearly different from that under the curve defined by Path B . Clearly, the work ${}_1W_2$ depends on the path selected, and not simply the end points. Obviously then, to calculate the work, we will need full information on $P(V)$ for the process under consideration.

Many processes in thermodynamics are well modeled as a

- **POLYTROPIC PROCESS:** a process that is described well by an equation of the form $PV^n = \text{constant} = C$.

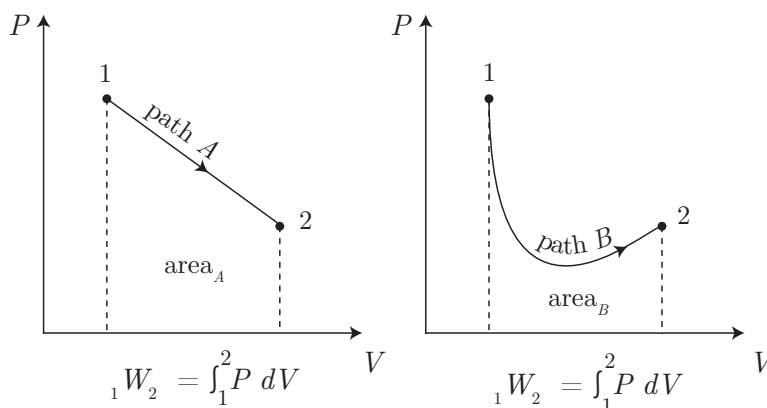

Figure 3.8: $P - V$ diagram for work for two different processes connecting the same states.

Here, n is known as the polytropic exponent.

Example 3.10

Find the work for a gas undergoing a polytropic process with $n \neq 1$.

A polytropic process has

$$P(V) = \frac{C}{V^n}. \quad (3.75)$$

So the work is

$${}_1W_2 = \int_1^2 \frac{C}{V^n} dV = C \int_1^2 \frac{dV}{V^n}, \quad (3.76)$$

$$= \frac{C}{1-n} V^{1-n} \Big|_1^2, \quad (3.77)$$

$$= \frac{C}{1-n} (V_2^{1-n} - V_1^{1-n}). \quad (3.78)$$

Now, $C = P_1 V_1^n = P_2 V_2^n$, so

$${}_1W_2 = \frac{P_2 V_2 - P_1 V_1}{1-n}. \quad (3.79)$$

Note this formula is singular if $n = 1$.

Now, if $n = 1$, we have $PV = C$, that corresponds to an isothermal process if the material is also an ideal gas. Note that non-ideal gases can also have $PV = C$; they just are not isothermal. We need to be able to analyze polytropic processes with $n = 1$.

Example 3.11

Find the work for a gas undergoing a polytropic process with $n = 1$.

For this process, we have

$$P(V) = \frac{C}{V}. \quad (3.80)$$

Therefore the work is

$${}_1W_2 = \int_1^2 C \frac{dV}{V} = C \ln \frac{V_2}{V_1}. \quad (3.81)$$

Because $P_1V_1 = C$, we can say

$${}_1W_2 = P_1V_1 \ln \frac{V_2}{V_1}. \quad (3.82)$$

Example 3.12

Find the work for an isobaric process.

An isobaric process is a polytropic process with $n = 0$. Thus

$$P(V) = C = P_1. \quad (3.83)$$

We also have $P_2 = P_1$. The work is

$${}_1W_2 = \int_1^2 P_1 dV = P_1 \int_1^2 dV = P_1(V_2 - V_1). \quad (3.84)$$

Example 3.13

Find the work for an isochoric process.

An isochoric process has $dV = 0$. Thus

$${}_1W_2 = \int_1^2 P \underbrace{dV}_{=0} = 0. \quad (3.85)$$

There is no work for an isochoric process. This also corresponds to a polytropic process with $n \rightarrow \infty$.

Figure 3.9: $P - V$ diagram for various polytropic processes.

Figure 3.10: Sketch of two-step, isothermal-isobaric, compression of an ideal gas.

A family of paths in the $P - V$ plane for a set of polytropic processes of varying n is shown in Fig. 3.9.

Example 3.14

An ideal gas undergoes a two-step process. Beginning at state 1, it is isothermally compressed to state 2. Then it is isobarically compressed to state 3. Find the work.

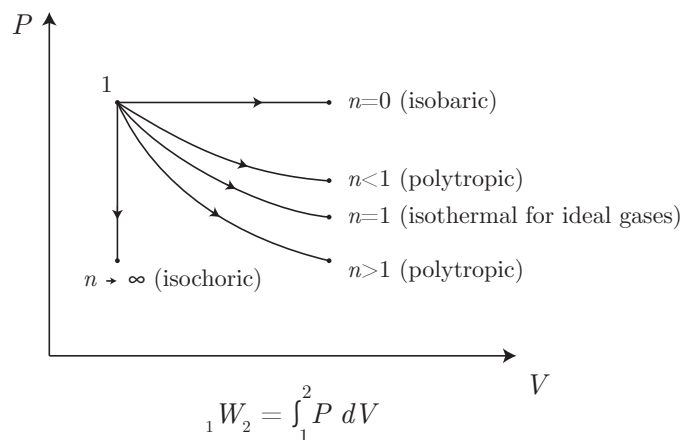
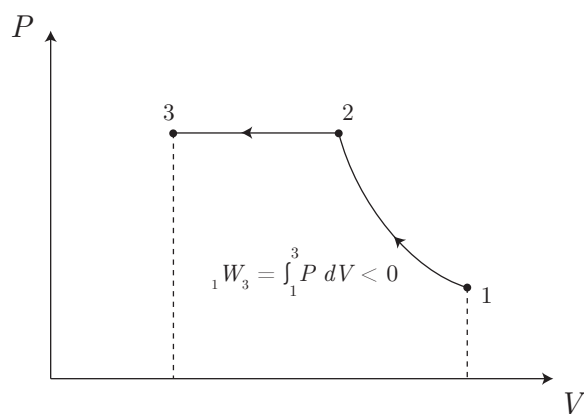
The process is sketched in Fig. 3.10. We have

$${}_1W_3 = {}_1W_2 + {}_2W_3, \quad (3.86)$$

$$= \int_1^2 P dV + \int_2^3 P dV, \quad (3.87)$$

$$= mRT_1 \int_1^2 \frac{dV}{V} + P_2 \int_2^3 dV, \quad (3.88)$$

$$= mRT_1 \ln \frac{V_2}{V_1} + P_2(V_3 - V_2), \quad (3.89)$$

$$= P_1 V_1 \ln \frac{V_2}{V_1} + P_2(V_3 - V_2). \quad (3.90)$$

Note that ${}_1W_3 < 0$, because $V_2 < V_1$ and $V_3 < V_2$. So *work is done on the system in compressing it*. Note also that even though we do not know T , we can solve the problem. This is because work only requires information about the P - V state of the system and the nature of the process.

Example 3.15

Consider the piston-cylinder arrangement sketched in Fig. 3.11. Here, $m = 2$ kg of water is initially

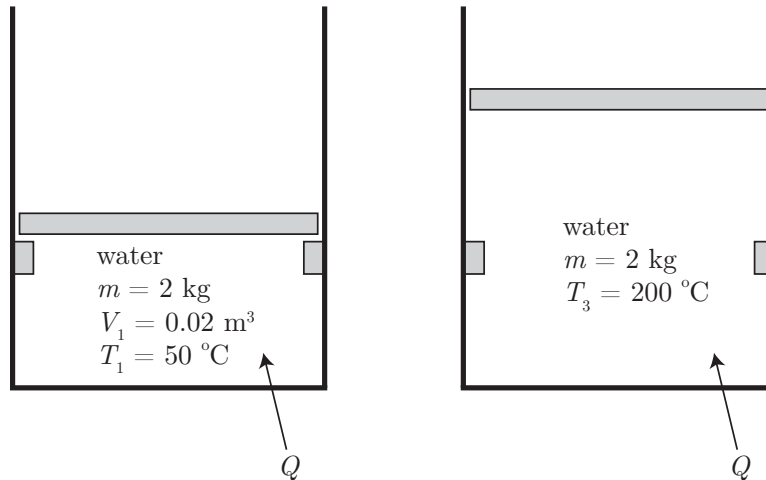

Figure 3.11: Sketch of piston-cylinder arrangement for water heating example.

at $V_1 = 0.02$ m³, $T_1 = 50$ °C. When $P = 100$ kPa, the piston leaves the stops. The water is heated from its initial state to a final state of 200 °C. Find diagrams for the process in the $P - T$, $T - v$, and $P - v$ planes and the work done by the water.

At state 1, we have

$$v_1 = \frac{V_1}{m} = \frac{0.02 \text{ m}^3}{2 \text{ kg}} = 0.01 \frac{\text{m}^3}{\text{kg}}. \quad (3.91)$$

Go to the saturated water tables, temperature entry. At $T_1 = 50\text{ }^\circ\text{C}$, we find $v_f = 0.001012\text{ m}^3/\text{kg}$ and $v_g = 12.0318\text{ m}^3/\text{kg}$. This gives $v_{fg} = 12.0308\text{ m}^3/\text{kg}$. Because $v_f < v_1 < v_g$, we have a two-phase mixture at the initial state. This fixes $P_1 = 12.350\text{ kPa}$.

Now, we have

$$x_1 = \frac{v_1 - v_f}{v_{fg}} = \frac{\left(0.01\frac{\text{m}^3}{\text{kg}}\right) - \left(0.001012\frac{\text{m}^3}{\text{kg}}\right)}{12.0308\frac{\text{m}^3}{\text{kg}}} = 0.000747083. \quad (3.92)$$

Next, heat at constant volume until

- the piston leaves the stops at $P = 100\text{ kPa}$, or
- the fluid becomes saturated.

We search the saturated water tables and examine the state at $P = 100\text{ kPa}$. We see at that pressure that $v_f = 0.001043\text{ m}^3/\text{kg}$ and $v_g = 1.69400\text{ m}^3/\text{kg}$. So when P reaches 100 kPa , we still have $v_f < v < v_g$, so the water is still a two-phase mixture.

We define then state 2 as the state where $P_2 = 100\text{ kPa}$ with $v_2 = v_1 = 0.01\text{ m}^3/\text{kg}$. From here on the process is isobaric. It is useful at this stage to consider a sketch of the processes given in Fig. 3.12. Now, at $P_2 = 100\text{ kPa}$, we find that $T_2 = 99.62\text{ }^\circ\text{C}$. And we have $v_2 = v_1 = 0.01\text{ m}^3/\text{kg}$. Using v_f and

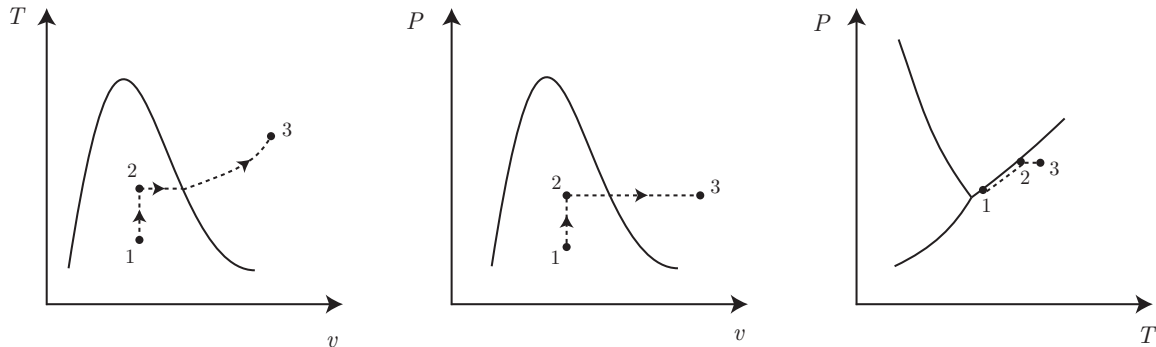

Figure 3.12: Sketch of $T - v$, $P - v$, and $P - T$ diagrams.

v_g at $P = 100\text{ kPa}$, we find

$$x_2 = \frac{v_2 - v_f}{v_{fg}} = \frac{\left(0.01\frac{\text{m}^3}{\text{kg}}\right) - \left(0.001043\frac{\text{m}^3}{\text{kg}}\right)}{1.69296\frac{\text{m}^3}{\text{kg}}} = 0.00529073. \quad (3.93)$$

Now, we heat isobarically until $T_3 = 200\text{ }^\circ\text{C}$, with $P_3 = P_2 = 100\text{ kPa}$. This gives us two properties, so we know the state. The superheat tables give us $v_3 = 2.17226\text{ m}^3/\text{kg}$.

Now, the final volume is

$$V_3 = mv_3 = (2\text{ kg}) \left(2.17226\frac{\text{m}^3}{\text{kg}}\right) = 4.34452\text{ m}^3. \quad (3.94)$$

Let us get the work.

$${}_1W_3 = \underbrace{{}_1W_2}_{=0} + {}_2W_3. \quad (3.95)$$

But ${}_1W_2 = 0$ because this is an isochoric process. So

$${}_1W_3 = {}_2W_3 = \int_2^3 P dV = P_2 \int_2^3 dV = P_2(V_3 - V_2) = P_2 m(v_3 - v_2). \quad (3.96)$$

Substituting numbers, we find

$${}_1W_3 = (100 \text{ kPa})(2 \text{ kg}) \left(\left(2.17226 \frac{\text{m}^3}{\text{kg}} \right) - \left(0.01 \frac{\text{m}^3}{\text{kg}} \right) \right) = \boxed{432.452 \text{ kJ}}. \quad (3.97)$$

A summary table is given in Table 3.1.

Table 3.1: Numerical values for water heating example

| variable | units | state 1 | state 2 | state 3 |
|----------|--------------------------------|-------------|------------|---------|
| P | kPa | 12.350 | 100 | 100 |
| v | $\frac{\text{m}^3}{\text{kg}}$ | 0.01 | 0.01 | 2.17226 |
| T | $^\circ\text{C}$ | 50 | 99.62 | 200 |
| x | - | 0.000747083 | 0.00529073 | - |
| V | m^3 | 0.02 | 0.02 | 4.34452 |

Example 3.16

Measured $P - V$ data for an internal combustion engine is obtained. Estimate the work.

The data is given in Table 3.2. Here, we have $N = 6$ points. The best way to address this problem

Table 3.2: Values for P and V in an expansion process.

| P (bar) | V (cm^3) |
|-----------|-----------------------|
| 20.0 | 454 |
| 16.1 | 540 |
| 12.2 | 668 |
| 9.9 | 780 |
| 6.0 | 1175 |
| 3.1 | 1980 |

is via numerical integration. We could use a variety of methods like Simpson's rule. Let use a simpler and robust method based on the areas of an assembly of trapezoids. We will estimate

$${}_1W_2 = \int_1^2 P dV \simeq \sum_{i=1}^{N-1} P_i^{ave} \Delta V_i. \quad (3.98)$$

Here, we are taking the area of trapezoid i as the product of the base,

$$\Delta V_i = V_{i+1} - V_i, \quad i = 1, \dots, N - 1, \quad (3.99)$$

and the average pressure of trapezoid i ,

$$P_i^{ave} = \frac{P_i + P_{i+1}}{2}, \quad i = 1, \dots, N - 1. \quad (3.100)$$

If ΔV_i were uniform, one could show this is equivalent to the well-known trapezoidal method. We can summarize the calculations in Table 3.3. We see

Table 3.3: Tabular calculation of work.

| i | P bar | V cm ³ | P_i^{ave} bar | ΔV_i cm ³ | $P_i^{ave} \Delta V_i$ bar cm ³ |
|-----|------------|------------------------|--------------------|---------------------------------|---|
| 1 | 20.0 | 454 | 18.05 | 86 | 1552.3 |
| 2 | 16.1 | 540 | 14.15 | 128 | 1811.20 |
| 3 | 12.2 | 668 | 11.05 | 112 | 1237.6 |
| 4 | 9.9 | 780 | 7.95 | 395 | 3140.25 |
| 5 | 6.0 | 1175 | 4.55 | 805 | 3662.75 |
| 6 | 3.1 | 1980 | - | - | - |
| | | | | | 11404.1 |

$${}_1W_2 = \int_1^2 P dV \simeq \sum_{i=1}^{N-1} P_i^{ave} \Delta V_i = 11404.1 \text{ bar cm}^3. \quad (3.101)$$

Let us convert to kJ:

$$(11404.1 \text{ bar cm}^3) \left(\frac{100 \text{ kPa}}{\text{bar}} \right) \left(\frac{\text{m}^3}{(100 \text{ cm})^3} \right) \left(\frac{\text{kJ}}{\text{kPa m}^3} \right) = 1.14 \text{ kJ}. \quad (3.102)$$

A sketch of the process is given in Fig. 3.13.

Example 3.17

We are given air in the spring-restrained piston-cylinder arrangement of Fig. 3.14 with $P_1 = 100 \text{ kPa}$, $V_1 = 0.002 \text{ m}^3$, $x_1 = 0 \text{ m}$, no force on the piston at state 1, $P_{atm} = 100 \text{ kPa}$, and $A = 0.018 \text{ m}^2$. The air expands until $V_2 = 0.003 \text{ m}^3$. We know the spring is *linear* with $F_{spring} = kx$ with $k = 16.2 \text{ kN/m}$. Find the final pressure of the air and the work done by the air on the piston.

First note here that x is distance and not quality! The free body diagram is sketched in Fig. 3.14. For the piston to be in mechanical equilibrium, we require

$$PA = P_{atm}A + kx, \quad (3.103)$$

$$P = P_{atm} + \frac{k}{A}x. \quad (3.104)$$

Figure 3.13: Sketch of $P - V$ diagram.

Figure 3.14: Sketch of piston-spring problem.

This gives us $P(x)$. So at the initial state, where $x_1 = 0$, we have $P_1 = P_{atm} = 100$ kPa. We also need $V(x)$:

$$V(x) = V_1 + Ax. \quad (3.105)$$

Let us eliminate x . From Eq. (3.105), we get

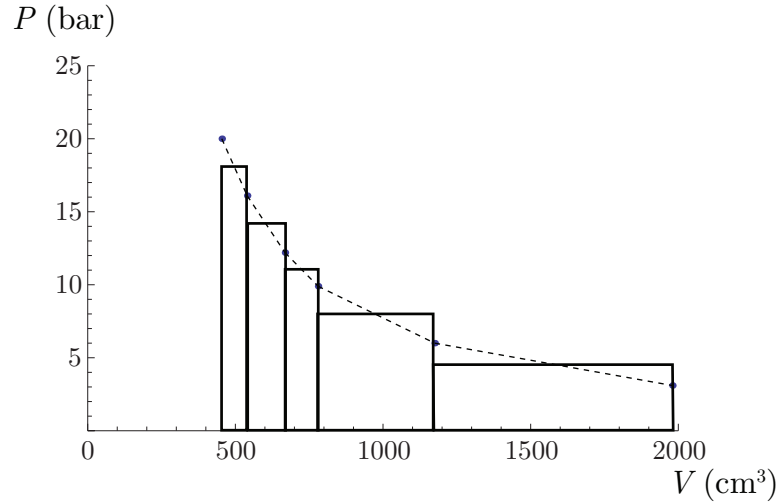
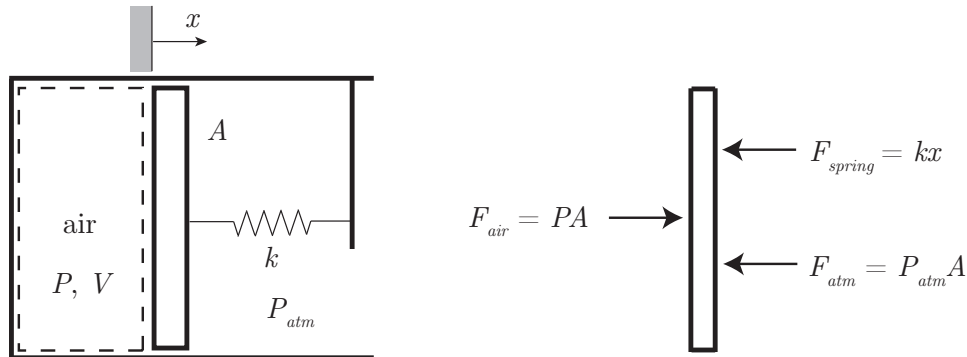
$$x = \frac{V - V_1}{A}. \quad (3.106)$$

Substitute Eq. (3.106) into Eq. (3.104) to get

$$P = P_{atm} + \frac{k}{A} \left(\frac{V - V_1}{A} \right) = P_{atm} + \frac{k}{A^2} (V - V_1). \quad (3.107)$$

Note, when $V = V_1$, we find $P = P_{atm}$.

Now, to get the work, we take

$${}_1W_2 = \int_1^2 P dV = \int_{V_1}^{V_2} \underbrace{\left(P_{atm} + \frac{k}{A^2}(V - V_1) \right)}_{=P} dV. \quad (3.108)$$

We integrate this to find

$${}_1W_2 = \left[P_{atm}V + \frac{k}{2A^2}(V - V_1)^2 \right]_{V_1}^{V_2}, \quad (3.109)$$

$$= P_{atm}(V_2 - V_1) + \frac{k}{2A^2} \left((V_2 - V_1)^2 - \underbrace{(V_1 - V_1)^2}_{=0} \right), \quad (3.110)$$

$$= \underbrace{P_{atm}(V_2 - V_1)}_{\text{work done on atmosphere}} + \underbrace{\frac{1}{2}k \left(\frac{V_2 - V_1}{A} \right)^2}_{\text{work done on spring}} \quad (3.111)$$

The $P - V$ diagram is sketched in Fig. 3.15. Let us calculate the numerical values.

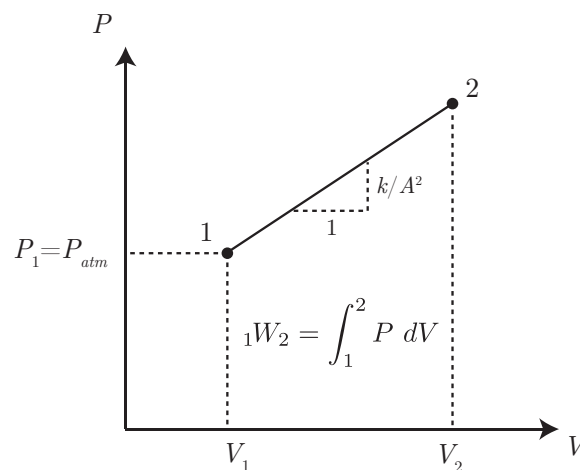

Figure 3.15: Sketch of $P - V$ diagram in piston-linear spring problem.

$$P_2 = (100 \text{ kPa}) + \left(16.2 \frac{\text{kN}}{\text{m}} \right) \frac{1}{(0.018 \text{ m}^2)^2} ((0.003 \text{ m}^3) - (0.002 \text{ m}^3)) = \boxed{150 \text{ kPa}}. \quad (3.112)$$

$${}_1W_2 = \underbrace{(100 \text{ kPa})((0.003 \text{ m}^3) - (0.002 \text{ m}^3))}_{0.1 \text{ kJ}} + \underbrace{\frac{1}{2} \left(16.2 \frac{\text{kN}}{\text{m}} \right) \left(\frac{(0.003 \text{ m}^3) - (0.002 \text{ m}^3)}{0.018 \text{ m}^2} \right)^2}_{0.025 \text{ kJ}}, \quad (3.113)$$

$$= \boxed{0.125 \text{ kJ}}. \quad (3.114)$$

Example 3.18

A gas is compressed from state (P_1, V_1) to (P_2, V_2) via two different paths, A and B :

- Path A : a polytropic process in which $PV^n = C$.
- Path B : an isobaric compression to (P_1, V_2) followed by an isochoric compression to (P_2, V_2) .

Determine the work along both paths.

First consider Path A . On Path A , we have

$$PV^n = C = P_1V_1^n = P_2V_2^n. \quad (3.115)$$

So

$$P = C \frac{1}{V^n}. \quad (3.116)$$

Now, the work is

$${}_1W_2 = \int_1^2 P dV = C \int_{V_1}^{V_2} \frac{dV}{V^n} = C \left[\frac{V^{1-n}}{1-n} \right]_{V_1}^{V_2} = C \left(\frac{V_2^{1-n} - V_1^{1-n}}{1-n} \right). \quad (3.117)$$

Now, using $C = P_1V_1^n = P_2V_2^n$, we get

$${}_1W_2 = \boxed{\frac{P_2V_2 - P_1V_1}{1-n}}. \quad (3.118)$$

Now, for Path B , we denote the intermediate state as $*$ and quickly calculate

$${}_1W_2 = \int_1^2 P dV = \int_1^* P dV + \int_*^2 P dV. \quad (3.119)$$

Now, the $*$ state has $V_* = V_2$, so

$${}_1W_2 = \int_1^2 P dV = \int_{V_1}^{V_2} P dV + \underbrace{\int_{V_2}^{V_2} P dV}_{=0}. \quad (3.120)$$

Now, because the first part of the process is isobaric with $P = P_1$, the first integral is easy. And the second integral is zero, because the integral has no width. So we get

$${}_1W_2 = P_1 \int_{V_1}^{V_2} dV = P_1(V_2 - V_1) = \boxed{P_1V_2 - P_1V_1}. \quad (3.121)$$

Note the work for the different paths is different!

$$\frac{P_2V_2 - P_1V_1}{1-n} \neq P_1V_2 - P_1V_1. \quad (3.122)$$

The two different paths are sketched in the $P - V$ diagrams of Fig. 3.16. In both processes, A and B , the work is negative. The gas is worked upon; it is thus doing negative work.

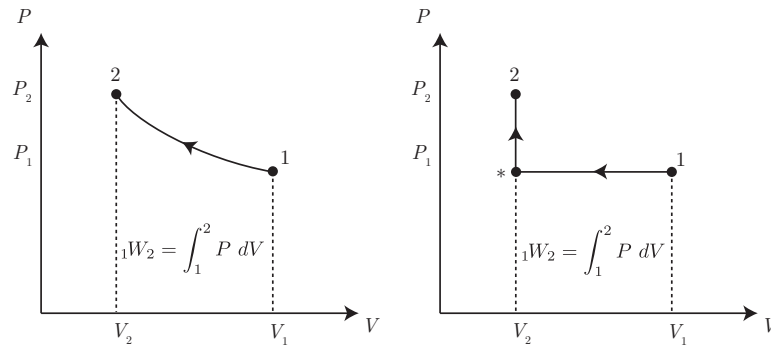
Figure 3.16: Sketch of $P - V$ diagrams for compression on two different paths.**Example 3.19**

A spherical balloon contains air at $P_1 = 150$ kPa and is placed in a vacuum. It has an initial diameter of $D_1 = 0.3$ m. The balloon is heated until its diameter is $D_2 = 0.4$ m. It is known that the pressure in the balloon is proportional to its diameter. Calculate the work of expansion.

The process is diagrammed in Fig. 3.17. We are told the pressure is proportional to the diameter.

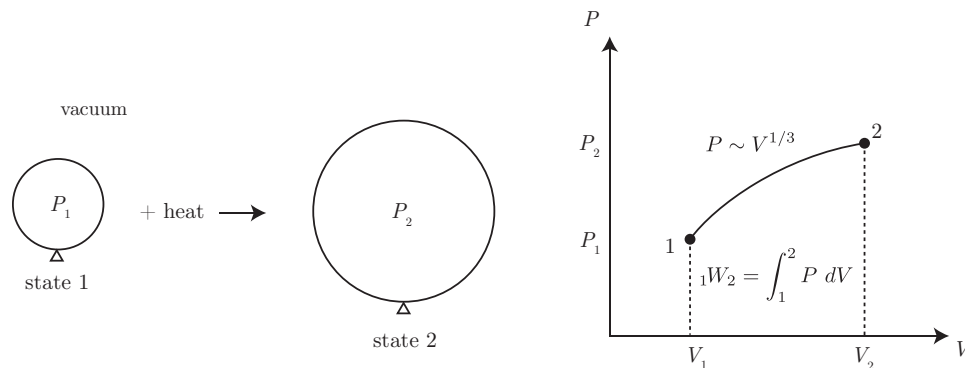

Figure 3.17: Diagrams for balloon heating problem

For a sphere we have

$$V = \frac{4}{3}\pi \left(\frac{D}{2}\right)^3 = \frac{\pi}{6}D^3. \quad (3.123)$$

So

$$D = \left(\frac{6V}{\pi}\right)^{1/3}. \quad (3.124)$$

Because the volume is proportional to the cube of the diameter, the diameter is proportional to the cube root of the volume. So the pressure is proportional to the cube root of the volume:

$$P = kD, \quad (3.125)$$

$$= k \left(\frac{6V}{\pi}\right)^{1/3}. \quad (3.126)$$

Here, we have defined the proportionality constant as k . The free body diagram is unusual and is sketched in Fig. 3.18. Here, we give a sketch only for a sector of the balloon. The interior air pressure

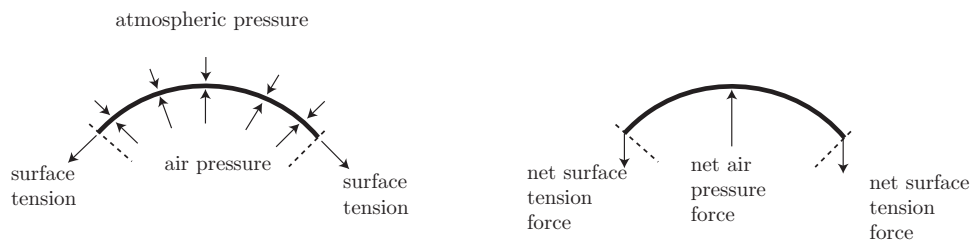

Figure 3.18: Free body diagram for a sector of the spherical balloon surface.

exerts a net upwards force on the balloon surface. The lateral pressure forces cancel each other. The net upwards force on this sector is balanced by a net downwards force exerted by the surface tension force of the balloon material.

Let us calculate the work:

$${}_1W_2 = \int_1^2 P dV, \quad (3.127)$$

$$= k \left(\frac{6}{\pi} \right)^{1/3} \int_{V_1}^{V_2} V^{1/3} dV, \quad (3.128)$$

$$= k \left(\frac{6}{\pi} \right)^{1/3} \left(\frac{3}{4} \right) \left[V^{4/3} \right]_{V_1}^{V_2}, \quad (3.129)$$

$$= k \left(\frac{6}{\pi} \right)^{1/3} \left(\frac{3}{4} \right) \left(V_2^{4/3} - V_1^{4/3} \right), \quad (3.130)$$

$$= k \left(\frac{6}{\pi} \right)^{1/3} \left(\frac{3}{4} \right) V_1^{4/3} \left(\left(\frac{V_2}{V_1} \right)^{4/3} - 1 \right). \quad (3.131)$$

Now, we know state 1, so this lets us determine k :

$$k = P_1 \left(\frac{6V_1}{\pi} \right)^{-1/3} \quad (3.132)$$

Thus, the work is

$${}_1W_2 = \underbrace{P_1 \left(\frac{6V_1}{\pi}\right)^{-1/3}}_k \left(\frac{6}{\pi}\right)^{1/3} \left(\frac{3}{4}\right) V_1^{4/3} \left(\left(\frac{V_2}{V_1}\right)^{4/3} - 1\right), \quad (3.133)$$

$$= P_1 V_1 \left(\frac{3}{4}\right) \left(\left(\frac{V_2}{V_1}\right)^{4/3} - 1\right), \quad (3.134)$$

$$= P_1 \underbrace{\left(\frac{4}{3}\pi \left(\frac{D_1}{2}\right)^3\right)}_{V_1} \left(\frac{3}{4}\right) \left(\left(\frac{D_2^3}{D_1^3}\right)^{4/3} - 1\right), \quad (3.135)$$

$$= P_1 \pi \left(\frac{D_1}{2}\right)^3 \left(\left(\frac{D_2}{D_1}\right)^4 - 1\right), \quad (3.136)$$

$$= (150 \text{ kPa}) \pi \left(\frac{0.3 \text{ m}}{2}\right)^3 \left(\left(\frac{0.4 \text{ m}}{0.3 \text{ m}}\right)^4 - 1\right), \quad (3.137)$$

$$= \boxed{3.43612 \text{ kJ.}} \quad (3.138)$$

3.2.3 Other forms of work

We note that there are other forces besides pressure forces, and those forces can also do work. Consider

- a stretching wire stretched by tension force \mathcal{T} through length change dL . The differential work is

$$\delta W = -\mathcal{T} dL. \quad (3.139)$$

- a surface with surface tension \mathcal{S} . The differential work is

$$\delta W = -\mathcal{S} dA. \quad (3.140)$$

- a system with electric work where \mathcal{E} is the electric field strength, q is the particle charge, and x is the distance:

$$\delta W = -q\mathcal{E} dx. \quad (3.141)$$

In total, for materials that are more than simple compressible substances, we have

$$\delta W = P dV - \mathcal{T} dL - \mathcal{S} dA - q\mathcal{E} dx - \dots \quad (3.142)$$

It can be shown that the more work modes we include, the more independent thermodynamic variables are necessary to specify the state of the system.

Lastly we note that a gas expanding into a vacuum has ${}_1W_2 \neq \int_1^2 P dV$ because it is inherently a non-equilibrium process.

3.3 Heat

Let us make the following definition:

- **HEAT**: a form of energy transferred across the boundary of a system at a given temperature to another system (or the surroundings) at a different temperature by virtue of the temperature difference between the two.

We adopt the notion that bodies do not contain heat, but that heat only has relevance as a type of energy that crosses system boundaries. Note that work is in a similar class; it is not contained within a system, but can be identified when it crosses system boundaries. We will make a distinction between heat and work energy transfers.

We also note that when two bodies are at the same temperature, there can be no heat transferred between the two bodies. The subject of *heat transfer* considers the details of the heat transfer process. There are three fundamental classes of heat transfer:

- *heat diffusion, also called conduction*. Physically this is due to local effects. Bacon is fried via conduction effects as a culinary example. This is characterized by Fourier's law¹

$$\mathbf{q} = -k\nabla T, \quad (3.143)$$

where \mathbf{q} is the *heat flux vector* with units $\text{J/s/m}^2 = \text{W/m}^2$, k is the *thermal conductivity* with units $\text{J/s/m/K} = \text{W/m/K}$, and ∇T is the vector representing the gradient of temperature. Recall that ∇T is a vector pointing in the direction in which T rises most rapidly. Because of the minus sign, we see then that the thermal energy flows in the direction of most rapid temperature decrease. This law was developed by Joseph Fourier, who built an elegant and correct theory of a special case of non-equilibrium thermodynamics before the laws of equilibrium thermodynamics were formulated, let alone fully understood. Fourier is depicted in Fig. 3.19.

In one dimension and also neglecting any time-dependency, we get

$$\mathbf{q} = -k \frac{dT}{dx}. \quad (3.144)$$

If we multiply by the local cross-sectional area, we find $\dot{Q} = \mathbf{q}A$, and

$$\dot{Q} = -kA \frac{dT}{dx} \sim -kA \frac{T_{\text{hot}} - T_{\text{cold}}}{L}. \quad (3.145)$$

Here, \dot{Q} has units J/s or W (Watts).

¹J. B. J. Fourier, 1822, *Théorie Analytique de la Chaleur*, Chez Firmin Didot, Paris. 1878 English translation.



Figure 3.19: Jean Baptiste Joseph Fourier (1768-1830), French physicist and mathematician who developed a correct theory of heat conduction. Image from <http://mathshistory.st-andrews.ac.uk/Biographies/Fourier.html>.

- *convection*. This is actually a version of conduction, albeit enhanced by fluid flow. For some systems, convective effects are well modeled by Newton's law of cooling^{2,3} :

$$\mathbf{q} = h(T_{hot} - T_{cold}), \quad (3.146)$$

$$\dot{Q} = \mathbf{q}A = hA(T_{hot} - T_{cold}). \quad (3.147)$$

Here, h is a constant with units $\text{W}/\text{m}^2/\text{K}$.

- *thermal radiation*. Physically this is due to remote effects. The earth is heated by the sun via radiation effects, not conductive energy diffusion. For some systems, the radiative heat transfer rate is well modeled by

$$\mathbf{q} = \sigma(T_{hot}^4 - T_{cold}^4), \quad (3.148)$$

$$\dot{Q} = \mathbf{q}A = \sigma A(T_{hot}^4 - T_{cold}^4). \quad (3.149)$$

Here, σ is the Stefan-Boltzmann constant, $\sigma = 5.67 \times 10^{-8} \text{ W}/\text{m}^2/\text{K}^4$.

We adopt the traditional engineering sign convention for heat:

- + heat enters the system,
- - heat leaves the system.

²Anonymous, 1701, "Scala graduum caloris," *Philosophical Transactions*, 270: 824-829; often attributed to I. Newton.

³J. A. Ruffner, 1963, "Reinterpretation of the genius of Newton's 'law of cooling,'" *Archive for History of Exact Sciences*, 2(2):138-152.

The sign convention again is motivated by nineteenth century steam engines. Heat had to be added into a system to get work out of the system. Because engineers were and are concerned with this problem, this convention is taken.

We define a special kind of process in which $Q = 0$ as

- **ADIABATIC**: a type of process for which there is no heat transfer.

The word “adiabatic” was first used by Rankine.⁴ It is from the Greek $\acute{\alpha}\delta\iota\acute{\alpha}\beta\alpha\tau\acute{o}\varsigma$: not to be passed through; in detail, $\acute{\alpha}$ (not) + $\delta\iota\acute{\alpha}$ (through) + $\beta\alpha\tau\acute{o}\varsigma$ (passable). An image of Rankine’s text containing the first use of the word is shown in Fig. 3.20.

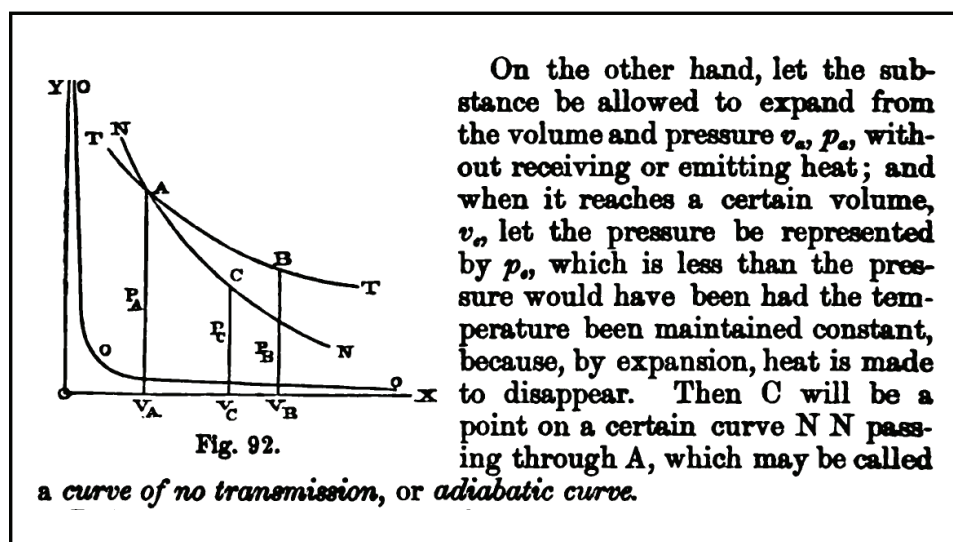

Figure 3.20: Image of the first modern use of the word “adiabatic” from Rankine’s 1859 text.

As is work, heat transfer is a path-dependent function characterized by inexact differentials. We take

$${}_1Q_2 = \int_1^2 \delta Q, \quad (3.150)$$

$$\dot{Q} = \frac{\delta Q}{dt}, \quad (3.151)$$

$$q = \frac{Q}{m}. \quad (3.152)$$

Here, q is the specific thermal energy transfer. It has units J/kg. Note $q \neq \mathbf{q}$, where \mathbf{q} is the heat flux with units W/m². In this thermodynamics course, we will mainly be concerned with q . In a heat transfer course, \mathbf{q} is more important.

⁴W. J. M. Rankine, 1859, *A Manual of the Steam Engine and Other Prime Movers*, Griffin, London, p. 302.

Now, ${}_1W_2 = \int_1^2 P dV$. We will see in future chapters that there is an equivalent for heat in that ${}_1Q_2 = \int_1^2 T dS$, where S is the *entropy*, to be defined later in Ch. 6.

We finish with some notes of comparison:

- Q and W as well as q and w are affiliated with transient phenomena; both cross boundaries when the system changes state.
- Q and W as well as q and w only exist at system boundaries.
- Q and W as well as q and w are both path-dependent, have inexact differentials, and are not properties of the system.

3.4 Representations of the first law

There are a variety of ways to represent the first law of thermodynamics, also known as the principle of *conservation of energy*. Some of them are not obvious, but have withstood the scrutiny of detailed experiment. Perhaps the simplest, but also the most obtuse, is the following.

3.4.1 Cycle

- **FIRST LAW OF THERMODYNAMICS:** During any cycle, the cyclic integral of heat added to a system is proportional to the cyclic integral of work done by the system.

If we denote a cyclic integral, also known as a closed contour integral, by \oint , the mathematical representation of this law is

$$\mathcal{J} \oint \delta Q = \oint \delta W, \quad (Q \text{ in cal, } W \text{ in J}). \quad (3.153)$$

Here \mathcal{J} is a proportionality constant, sometimes known as the *mechanical equivalent of heat*. Now, during the development of thermodynamics, Q was measured in cal, where 1 cal represented the energy necessary to raise 1 g of water 1 °C, and W was measured in J that represented the work done in moving a 1 kg mass against a gravitational field of strength $g = 1 \text{ m/s}^2$ through a distance of 1 m.

In the now-discredited caloric theory, heat was thought to be a fluid and not explicitly related to work. This theory began to lose credibility with the experiments conducted in Bavaria by the colorful American scientist Benjamin Thompson⁵ (Count Rumford). By doing work in boring a cannon immersed in water and boiling the water, Thompson was able to demonstrate that the work of boring was converted into heat. Thompson's image is shown in Fig. 3.21a. Thompson's etching of the cannon used in his experiment is reproduced in Fig. 3.21b.

⁵B. Thompson (Count Rumford), 1798, "An inquiry concerning the source of the heat that is excited by friction," *Philosophical Transactions of the Royal Society of London*, 88: 80-102.

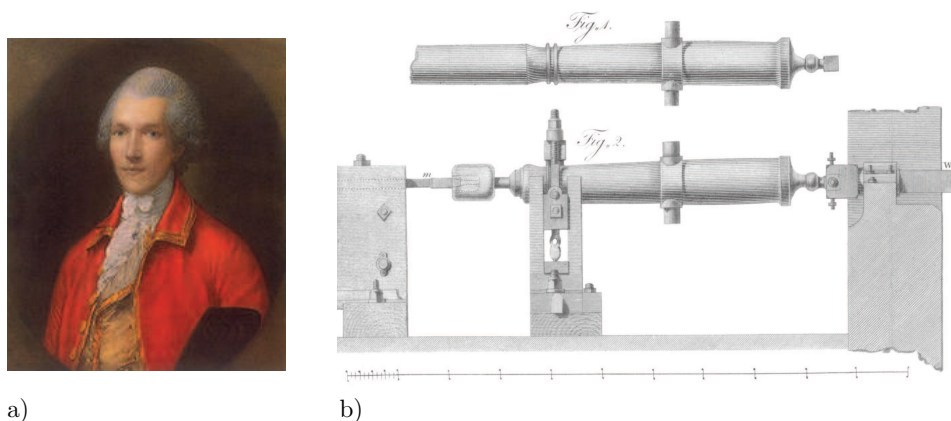

Figure 3.21: a) Benjamin Thompson (Count Rumford) (1753-1814) in a 1783 portrait by Thomas Gainsborough. American scientist whose cannon-boring experiments discredited the caloric theory. Image from https://en.wikipedia.org/wiki/Benjamin_Thompson, b) Image of cannon from B. Thompson (Count Rumford), 1798, “An inquiry concerning the source of the heat which is excited by friction,” *Philosophical Transactions of the Royal Society of London*, 88: 80-102.

In the 1840s there was considerable effort to relate mechanical and thermal energy and thus measure \mathcal{J} . There is some controversy over who first quantified this value. By many accounts Julius Robert von Mayer achieved the first success in 1842,⁶ though his exposition often lacked the mathematical and experimental support that many scientists demand. Mayer is pictured in Fig. 3.22. Contemporaneously, and with more publicity, Joule spent considerable effort in carefully measuring \mathcal{J} .^{7,8} He estimated $\mathcal{J} = 4.41$ J/cal, that has since been corrected to

$$\mathcal{J} = 4.1860 \frac{\text{J}}{\text{cal}}. \quad (3.154)$$

We give a portrait of Joule in Fig. 3.23a. A nineteenth century etching of Joule’s device is given in Fig. 3.23b. A modern full-scale replica of Joule’s apparatus designed and constructed by Mr. Leon Hluchota and Prof. Patrick F. Dunn, based upon Joule’s original experimental display in the Science Museum, London, and formally in use in undergraduate laboratories at the University of Notre Dame, is shown in Fig. 3.23c.

⁶J. R. Mayer, 1842, “Bemerkungen über die Kräfte der unbelebten Natur,” *Annalen der Chemie und Pharmacie*, 42: 233-240.

⁷J. P. Joule, 1845, “On the existence of an equivalent relation between heat and the ordinary forms of mechanical power,” *The London, Edinburgh and Dublin Philosophical Magazine and Journal of Science*, Ser. 3, 27: 205-207.

⁸J. P. Joule, 1850, “On the mechanical equivalent of heat,” *Philosophical Transactions of the Royal Society of London*, 140: 61-82.



Figure 3.22: Julius Robert von Mayer (1814-1878). German physician and physicist who in 1842 said “Energy can be neither created nor destroyed.” Image from https://en.wikipedia.org/wiki/Julius_Robert_von_Mayer.

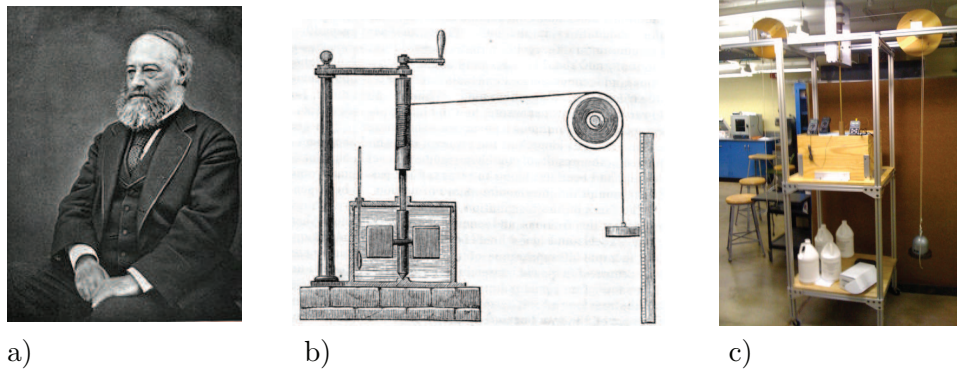

Figure 3.23: a) James Prescott Joule (1818-1889). English experimentalist who demonstrated the mechanical equivalent of heat. Image from https://en.wikipedia.org/wiki/James_Prescott_Joule, b) Sketch of Joule's original apparatus, from *Harper's New Monthly Magazine*, No. 231, August 1869, c) Operational full-scale replication of Joule's apparatus at the University of Notre Dame.

While Joule performed the key experiments, the critical acceptance of the first law is attributed by many to the work of Hermann von Helmholtz,⁹ pictured in Fig. 3.24. However,



Figure 3.24: Hermann Ludwig Ferdinand von Helmholtz (1821-1894). German physician and physicist who impacted nearly all of nineteenth century mechanics. Image from <http://mathshistory.st-andrews.ac.uk/Biographies/Helmholtz.html>.

Truesdell notes that in this work Helmholtz restricts his conservation principle to kinetic and potential energies.¹⁰ The classical theoretical framework for the first law and more was firmly solidified by Rudolf Clausius.¹¹ Clausius is depicted in Fig. 3.25.

⁹H. Helmholtz, 1847, *Über die Erhaltung der Kraft*, Reimer, Berlin.

¹⁰C. Truesdell, 1980, *The Tragicomical History of Thermodynamics 1822-1854*, Springer, New York, p. 161.

¹¹R. Clausius, 1850, "Ueber die bewegende Kraft der Wärme und die Gesetze, welche sich daraus für die Wärmelehre selbst ableiten lassen," *Annalen der Physik und Chemie* 79: 368-397.



Figure 3.25: Rudolf Julius Emmanuel Clausius (1822-1888). German theoretician who systematized classical thermodynamics into a science. Image from <http://mathshistory.st-andrews.ac.uk/Biographies/Clausius.html>.

Now, in this class, we will not bother much with the mechanical equivalent of heat, and simply insist that Q be measured in units of work. When Q has units of J, then $\mathcal{J} = 1$, and we recover our preferred form of the first law:

$$\boxed{\oint \delta Q = \oint \delta W}, \quad (Q \text{ in J, } W \text{ in J}). \quad (3.155)$$

3.4.2 Process

We arrive at an alternate representation of the first law by the following analysis. Consider the sketch of Fig. 3.26. Now, consider two cycles, each passing through points 1 and 2, albeit

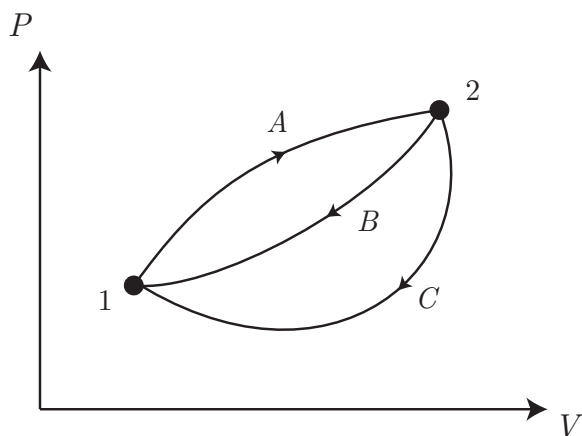

Figure 3.26: Sketch of $P - V$ diagram for various combinations of processes forming cyclic integrals.

via different paths:

- Cycle *I*: 1 to 2 on Path *A* followed by 2 to 1 on Path *B*,
- Cycle *II*: 1 to 2 on Path *A* followed by 2 to 1 on Path *C*.

The only difference between Cycles *I* and *II* is they take different return paths. Now, write the first law $\oint \delta Q = \oint \delta W$ for Cycle *I*:

$$\int_1^2 \delta Q_A + \int_2^1 \delta Q_B = \int_1^2 \delta W_A + \int_2^1 \delta W_B, \quad \text{Cycle } I. \quad (3.156)$$

For Cycle *II*, we have similarly

$$\int_1^2 \delta Q_A + \int_2^1 \delta Q_C = \int_1^2 \delta W_A + \int_2^1 \delta W_C, \quad \text{Cycle } II. \quad (3.157)$$

Now, subtract Eq. (3.157) from Eq. (3.156) to get

$$\int_2^1 \delta Q_B - \int_2^1 \delta Q_C = \int_2^1 \delta W_B - \int_2^1 \delta W_C. \quad (3.158)$$

Rearrange Eq. (3.158) to get

$$\int_2^1 (\delta Q - \delta W)_B = \int_2^1 (\delta Q - \delta W)_C. \quad (3.159)$$

Now, *B* and *C* are *arbitrary* paths; Eq. (3.159) asserts that the integral of $\delta Q - \delta W$ from 2 to 1 is *path-independent*. This is in spite of the fact that both *W* and, as we will see later, *Q* are path-dependent quantities. Therefore, we can deduce that this defines

- **ENERGY**: a thermodynamic property that is a theoretical construct suggested by the first law of thermodynamics as something to account for the difference between heat transfer and work in any process between the same start and end states.

Energy is a new extensive property of the system denoted by *E*. While we like to think we have intuition for what constitutes energy, it really is an elusive quantity. Viewed at another way, the Newtonian mechanical energy is easily visualized in terms of kinetic and potential energy, but it is not always conserved! Our new energy includes thermal energy, that we think we can easily feel, so we still have a good intuition for it. So we have generalized energy so that it is always conserved, at the expense of losing the ability to easily visualize it.

Recall that properties depend only on the state and not the path taken to arrive at the state. Let us then take the following definition for the differential of *E*:

$$\boxed{dE = \delta Q - \delta W.} \quad (3.160)$$

If we integrate from 1 to 2, we get

$$\int_1^2 dE = \int_1^2 \delta Q - \int_1^2 \delta W, \quad (3.161)$$

yielding

$$\boxed{E_2 - E_1 = {}_1Q_2 - {}_1W_2.} \quad (3.162)$$

Equation (3.162) is the alternate representation of the

- **FIRST LAW OF THERMODYNAMICS:** For a system undergoing a process, the change in energy is equal to the heat added to the system minus the work done by the system.

As mentioned at the beginning of this section, the first law of thermodynamics is often referred to as conservation of energy. Literally, conservation implies that there is no change. In order for energy not to change, and thus be formally conserved, we would have to insist that either ${}_1Q_2 = {}_1W_2$, or more restrictively, that the process be adiabatic and isochoric so that ${}_1Q_2 = {}_1W_2 = 0$. In either case $E_2 = E_1$. Thus, the first law, $E_2 - E_1 = {}_1Q_2 - {}_1W_2$, is actually a statement of *evolution of energy* in response to heat and work. However, this is unusual usage, and most people use the first law interchangeably with energy conservation.

Now, we consider E to represent the *total energy* of the system. It has units of J. It includes energy that is

- potential,
- kinetic,
- thermal,
- chemical,
- electric,
- magnetic,
- etc.

We will find it useful to lump all of the types of energy that are not potential or kinetic into a single term U , that we call

- **INTERNAL ENERGY:** that portion of total energy E that is not kinetic or potential energy. It includes thermal, chemical, electric, magnetic, and other forms of energy.

We take U to have units of J. We call the kinetic energy KE and the potential energy PE . So we take

$$\underbrace{E}_{\text{total energy}} = \underbrace{U}_{\text{internal energy}} + \underbrace{KE}_{\text{kinetic energy}} + \underbrace{PE}_{\text{potential energy}}. \quad (3.163)$$

In this course we shall mainly be concerned with changes of U that are associated with changes of the thermal energy of the system. A useful way to think of thermal energy is

- THERMAL ENERGY: kinetic energy associated with random motions of molecules at the *microscale*.

We can only observe this microscale kinetic energy with great difficulty. We usually have no hope of having any detailed knowledge of it, and so only consider it in the average. In fact, the temperature is a measure of the average microscale kinetic energy. We distinguish the thermal energy from KE , that we take to exist at the observable macroscale.

Each form of energy is an extensive property of the system. Taking differentials of Eq. (3.163), we get

$$dE = dU + d(KE) + d(PE). \quad (3.164)$$

So the first law, $dE = \delta Q - \delta W$, can be written as

$$dU + d(KE) + d(PE) = \delta Q - \delta W. \quad (3.165)$$

In the next two examples, let us consider two special cases of Eq. (3.165), that are familiar from Newtonian mechanics.

Example 3.20

Consider a system of mass m for which $dU = 0$, $d(PE) = 0$, and $\delta Q = 0$. Physically, this might correspond to a system with constant internal energy, held at constant height, and with no heat exchanges with its surroundings. For this system, the first law gives a balance between changes in kinetic energy and work. And let us assume that the system is being accelerated by a horizontal force F as it acts through a distance in the x direction. Assume there is no friction force.

We give a sketch in Fig. 3.27. The first law tells us



Figure 3.27: Sketch of system being accelerated by a force.

$$d(KE) = -\delta W. \quad (3.166)$$

Newtonian mechanics tells us

$$\delta W = -F dx. \quad (3.167)$$

The sign is negative because the system is being worked upon. It is not doing work. So we get

$$d(KE) = F dx. \quad (3.168)$$

Newton's second axiom tells us $F = m(d^2x/dt^2)$. And because $dx/dt = v$, we can say $F = m(dv/dt)$, so

$$d(KE) = m \frac{dv}{dt} dx. \quad (3.169)$$

Note we use v for velocity and distinguish that from v , the specific volume.

Let us divide both sides by dt to get

$$\frac{d(KE)}{dt} = m \frac{dv}{dt} \underbrace{\frac{dx}{dt}}_{=v}, \quad (3.170)$$

$$= m \frac{dv}{dt} v, \quad (3.171)$$

$$= mv \frac{dv}{dt}, \quad (3.172)$$

$$= m \frac{d}{dt} \left(\frac{v^2}{2} \right), \quad (3.173)$$

$$= \frac{d}{dt} \left(m \frac{v^2}{2} \right), \quad (3.174)$$

$$KE_2 - KE_1 = \frac{1}{2}mv_2^2 - \frac{1}{2}mv_1^2. \quad (3.175)$$

If we take $v_1 = 0$ and define the KE_1 as zero at this point, and take 2 to just be a general state, we get the commonly used

$$KE = \frac{1}{2}mv^2. \quad (3.176)$$

Note that

$$d(KE) = mv \, dv. \quad (3.177)$$

Example 3.21

Consider a system of mass m for which $dU = 0$, $d(KE) = 0$, and $\delta Q = 0$. Physically, this might correspond to a system with constant internal energy, held at constant upward velocity, with no heat exchanges with its surroundings. For this system, the first law gives a balance between changes in potential energy and work. And let us assume that the system is being raised at constant velocity v through distance z against a gravitational force, where the gravitational acceleration g is constant.

We give a sketch in Fig. 3.28. Newton's second axiom says that $m(d^2z/dt^2) = F - mg$. Now, we are

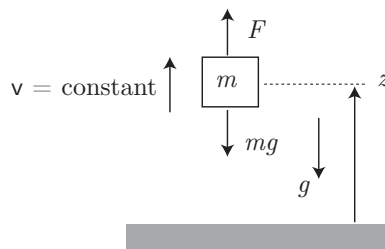

Figure 3.28: Sketch of system being raised at constant velocity v in a gravitational potential field, where g is constant.

told the velocity is constant, so the acceleration here is zero, so Newton's second axiom gives a force balance, $0 = F - mg$, thus

$$F = mg. \quad (3.178)$$

Now, the first law tells us, when $dU = 0$, $d(KE) = 0$, and $\delta Q = 0$, that

$$d(PE) = -\delta W. \quad (3.179)$$

Now

$$\delta W = -F dz. \quad (3.180)$$

We have a negative sign because the system is having work done *on* it by F . Thus

$$d(PE) = F dz. \quad (3.181)$$

Because $F = mg$, we get

$$d(PE) = mg dz. \quad (3.182)$$

Integrating, we find

$$PE_2 - PE_1 = mg(z_2 - z_1). \quad (3.183)$$

If we take PE_1 to be zero at $z_1 = 0$, and consider a general z , we get the commonly used

$$PE = mgz. \quad (3.184)$$

Note that

$$d(PE) = mg dz. \quad (3.185)$$

Now, because $dE = dU + d(KE) + d(PE)$ from Eq. (3.163), we can substitute from Eqs. (3.177, 3.185) to get

$$dE = dU + m\mathbf{v} d\mathbf{v} + mg dz. \quad (3.186)$$

Integrate Eq. (3.186) from state 1 to state 2 to get

$$E_2 - E_1 = U_2 - U_1 + \frac{1}{2}m(\mathbf{v}_2^2 - \mathbf{v}_1^2) + mg(z_2 - z_1). \quad (3.187)$$

Now, substitute Eq. (3.187) into Eq. (3.162) to obtain

$$\underbrace{U_2 - U_1 + \frac{1}{2}m(\mathbf{v}_2^2 - \mathbf{v}_1^2) + mg(z_2 - z_1)}_{=E_2-E_1} = {}_1Q_2 - {}_1W_2. \quad (3.188)$$

Now, if m is a constant, as it will be for a system, we can divide both sides by m to get

$$u_2 - u_1 + \frac{1}{2}(\mathbf{v}_2^2 - \mathbf{v}_1^2) + g(z_2 - z_1) = {}_1q_2 - {}_1w_2. \quad (3.189)$$

Here, we have defined the new intensive variables

- $u \equiv U/m$, the internal energy per unit mass, also known as the *specific internal energy*. It has units kJ/kg. It is an intensive thermodynamic property.
- ${}_1q_2 \equiv {}_1Q_2/m$, the heat transfer per unit mass. It has units kJ/kg and is *not* a thermodynamic property.
- ${}_1w_2 \equiv {}_1W_2/m$, the work per unit mass. It has units kJ/kg and is *not* a thermodynamic property.

3.5 Specific internal energy for general materials

Just as P , v , and T are thermodynamic properties, so is u . In fact, it can be considered to be one of the necessary two properties necessary to define a third. So, for example, if we are given P and u , we could find $v = v(P, u)$ or $T = T(P, u)$.

More importantly, let us consider the most general form for u ; a form where u is a function of at most two independent thermodynamic variables, say T and v ,

$$u = u(T, v). \quad (3.190)$$

For materials such as water, $u(T, v)$ is tabulated. Note that the tables must presume a reference value for energy so as to give it an absolute nature. However, as long as we confine our thermodynamics to a single substance, *differences in energy will be the only quantities that have relevance in determining physical quantities of interest*. That is to say, the reference state will not be important for single material problems. This is not true for multiple material problems such as when chemical reactions are present.

Similar to v_f and v_g , the tables have

- u_f : the specific internal energy of a saturated liquid, and
- u_g : the specific internal energy of a saturated vapor.

Also similar to v , we have

$$u_{fg} = u_g - u_f. \quad (3.191)$$

We also get a similar analysis for quality x as for volume. For a two-phase mixture, the total energy of the mixture is the sum of the energies of the components:

$$U = U_{liq} + U_{vap}, \quad (3.192)$$

$$mu = m_{liq}u_f + m_{vap}u_g, \quad (3.193)$$

$$u = \frac{m_{liq}}{m}u_f + \frac{m_{vap}}{m}u_g, \quad (3.194)$$

$$= \frac{m - m_{vap}}{m}u_f + \frac{m_{vap}}{m}u_g, \quad (3.195)$$

$$= (1 - x)u_f + xu_g, \quad (3.196)$$

$$= u_f + x(u_g - u_f), \quad (3.197)$$

$$= u_f + xu_{fg}. \quad (3.198)$$

We can solve for x by inverting Eq. (3.198) to get

$$x = \frac{u - u_f}{u_{fg}}. \quad (3.199)$$

Let us consider the heat transfer for an isochoric process in which we also have $\Delta KE = \Delta PE = 0$. Because the process is isochoric, ${}_1W_2 = \int_1^2 P dV = 0$. So the first law, Eq. (3.188), reduces to

$$U_2 - U_1 = {}_1Q_2, \quad (3.200)$$

$${}_1Q_2 = U_2 - U_1 = \Delta U. \quad (3.201)$$

The change in U gives the heat transfer for isochoric processes.

3.6 Specific enthalpy for general materials

Let us define a new thermodynamic property, *enthalpy*, in terms of known thermodynamic properties. The extensive total enthalpy H and intensive specific enthalpy h are defined as

$$H \equiv U + PV, \quad (3.202)$$

$$h = \frac{H}{m} = \frac{U}{m} + P\frac{V}{m}. \quad (3.203)$$

Thus,

$$\boxed{h = u + Pv}. \quad (3.204)$$

Its most important feature is its utility in control volume analysis that will be fully discussed in Ch. 4.1.2.2.4; its underlying mathematical rationale will be given in Ch. 9.3.

The first written use of the word “enthalpy” is given by Porter,¹² who notes the term was introduced by the Dutch physicist and Nobel laureate Heike Kamerlingh Onnes (1853-1926). The word is from the Greek $\acute{\epsilon}\nu\theta\acute{\alpha}\lambda\pi\epsilon\iota\nu$, meaning “to warm in.” We give an image of Porter’s citation of Onnes’ usage in Fig. 3.29.

Eq. (3.204) is valid for general materials. It will be seen to be useful for many problems, though in principle, we could get by with u alone just as well. Now, because u , P , and v are thermodynamic properties, so then is h :

$$h = h(T, P). \quad (3.205)$$

Sometimes tables give h and we need to find u ; thus,

$$u = h - Pv. \quad (3.206)$$

¹²A. W. Porter, 1922, “The generation and utilisation of cold,” *Transactions of the Faraday Society*, 18: 139-143.

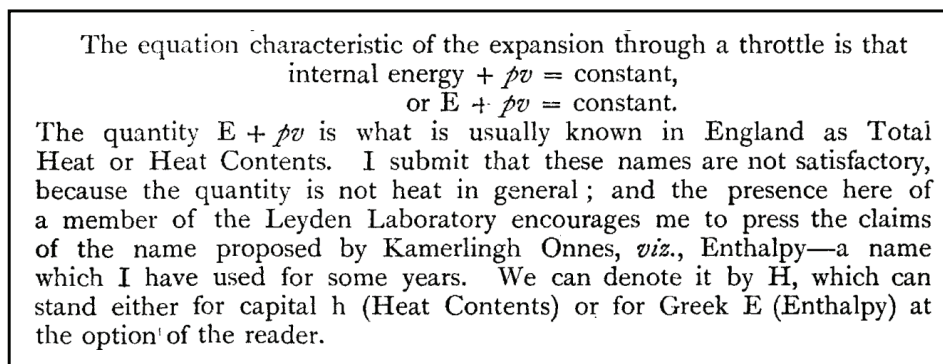

Figure 3.29: Image of first known printed use of the word “enthalpy” from Porter, 1922.

Similar to u , we can easily show

$$h = h_f + x h_{fg}, \quad x = \frac{h - h_f}{h_{fg}}. \quad (3.207)$$

The enthalpy is especially valuable for analyzing isobaric processes. Consider a special isobaric process in which $P_1 = P_2 = P$, $\Delta KE = \Delta PE = 0$. Then the first law, Eq. (3.188), reduces to

$$U_2 - U_1 = {}_1Q_2 - {}_1W_2. \quad (3.208)$$

Because ${}_1W_2 = \int_1^2 P dV = P(V_2 - V_1)$ for the isobaric process, the first law reduces to

$$U_2 - U_1 = {}_1Q_2 - P(V_2 - V_1), \quad (3.209)$$

$$= {}_1Q_2 - P_2 V_2 + P_1 V_1, \quad (3.210)$$

$${}_1Q_2 = \underbrace{(U_2 + P_2 V_2)}_{=H_2} - \underbrace{(U_1 + P_1 V_1)}_{=H_1}, \quad (3.211)$$

$$= H_2 - H_1 = \Delta H. \quad (3.212)$$

The change in H gives the heat transfer for isobaric processes.

3.7 Specific heat capacity

Sometimes when heat is added to a body, the temperature does not change, but the phase does, as in a vaporization or melting process. Such heat is called *latent heat*. Usually however, when heat is added to a body, we observe a temperature rise. We call this type of heat *sensible heat*, because we can sense it. The same amount of heat will raise the temperature of some materials more than others. When the sensible heat required to raise a unit mass by one degree is determined, it is called the *specific heat*. These notions were first systematized in the 1700s by the Scottish physicist Joseph Black,¹³ pictured in Fig. 3.30.

¹³J. Black, 1803, *Lectures on the Elements of Chemistry delivered in the University of Edinburgh by the Late Joseph Black, M.D.*, John Robinson, University of Edinburgh.

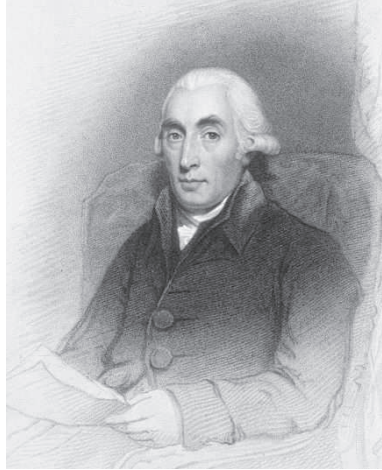

Figure 3.30: Joseph Black (1728-1799). Scottish physicist and chemist who pioneered calorimetry, discovered CO_2 , and financially supported James Watt’s research on steam power. Image from https://en.wikipedia.org/wiki/Joseph_Black.

We loosely define the

- **SPECIFIC HEAT CAPACITY:** the amount of heat needed to raise the temperature of a unit mass of material by one degree.

The word is a relic of the discredited caloric theory of heat in which heat was thought to be a fluid that could somehow fill its container. We often simply call it the “specific heat.” We give the specific heat the symbol c . It has units kJ/kg/K . Its loose mathematical definition is

$$c \simeq \frac{1}{m} \frac{\delta Q}{dT}. \quad (3.213)$$

We also define the extensive heat capacity as $C = \delta Q/dT$, where C has units kJ/K . We will not use C explicitly from here on.

It turns out that because δQ is path-dependent, so is c . So let us specify two common paths:

- **SPECIFIC HEAT AT CONSTANT VOLUME:** c_v . We determine this on a path that is isochoric. On such a path, the first law holds that $\delta Q = dU$, because $\delta W = 0$. So we take

$$c_v = \frac{1}{m} \left. \frac{\partial U}{\partial T} \right|_v. \quad (3.214)$$

Because $u = U/m$, and we take m to be constant, we get

$$\boxed{c_v = \left. \frac{\partial u}{\partial T} \right|_v}. \quad (3.215)$$

Now, for general materials $u = u(T, v)$, so we see that

$$c_v = c_v(T, v), \quad (3.216)$$

that is to say, $c_v(T, v)$ is itself a thermodynamic property for general materials. It can vary with two independent variables. We shall see later for some materials it varies only with T , and for other materials, it is actually a constant.

- SPECIFIC HEAT AT CONSTANT PRESSURE: c_P . We determine this on a path that is isobaric. On such a path, the first law holds that $\delta Q = dH$. So we take

$$c_P = \frac{1}{m} \left. \frac{\partial H}{\partial T} \right|_P. \quad (3.217)$$

Because $h = H/m$, and we take m to be constant, we get

$$\boxed{c_P = \left. \frac{\partial h}{\partial T} \right|_P}. \quad (3.218)$$

Now, for general materials $h = h(T, P)$, so we see that

$$c_P = c_P(T, P), \quad (3.219)$$

that is to say, $c_P(T, P)$ is itself a thermodynamic property for general materials. It can vary with two independent variables. We shall see later for some materials it varies only with T , and for other materials, it is actually a constant.

We also note that

- The work required for the isobaric expansion results in $\delta Q|_P > \delta Q|_v$ for a unit change in temperature. From this, it is easy to conclude that

$$\boxed{c_P > c_v}. \quad (3.220)$$

- SPECIFIC HEAT FOR INCOMPRESSIBLE MATERIALS: c . Most liquids and solids under moderate to low pressure conditions ($P < 1$ GPa) are well modeled as incompressible. Thus, in any heating process, there will be little if any associated work of compression. For such a material, there is no need to distinguish c_v and c_P , so we simply use c for the specific heat. We thus take

$$c(T) = \frac{du}{dT}. \quad (3.221)$$

Often, especially if the temperature changes are small, we can ignore the temperature variation of c for incompressible materials and simply take

$$c = \frac{du}{dT}. \quad (3.222)$$

More rigorous mathematical discussion of specific heat capacity will be given in Ch. 9.4.

3.8 Caloric equations of state

Recall that thermal equations of state are given by $P = P(T, v)$. We also have equations of state for the energy. We call such a relation a

- **CALORIC EQUATION OF STATE:** an equation that gives the energy as a function of two independent state variables. An example is the general form:

$$u = u(T, v). \quad (3.223)$$

In Ch. 9.4, we shall see there are restrictions on the form $u(T, v)$ can take. In a complicated fashion, the form of the caloric equation of state for $u(T, v)$ has some dependency on the thermal state equation $P = P(T, v)$.

One of the more confusing notions to beginning students of thermodynamics is which forms of energy and specific heat are appropriate for which materials. Here, we discuss them in more detail, moving from simple to complex.

3.8.1 Ideal gases

For ideal gases, we have $Pv = RT$. Ideal gases can be either *calorically perfect* or *calorically imperfect*. For all ideal gases, be they calorically perfect or calorically imperfect, it will be proved in Ch. 9.4 that the caloric equation of state takes on a simpler form:

$$u = u(T). \quad (3.224)$$

Now, we can specify h for an ideal gas. From Eq. (3.204), $h = u + Pv$, and the ideal gas law, $Pv = RT$, we get

$$h = u(T) + RT. \quad (3.225)$$

Thus, the enthalpy of an ideal gas is a function of T only:

$$h = h(T). \quad (3.226)$$

Now, for the specific heats of an ideal gas, Eq. (3.215) gives

$$c_v(T, v) = \left. \frac{\partial u}{\partial T} \right|_v = \frac{d}{dT}(u(T)) = c_v(T). \quad (3.227)$$

Separating variables in Eq. (3.227), we can also say for an ideal gas

$$du = c_v(T) dT. \quad (3.228)$$

For c_P , Eq. (3.218) gives

$$c_P(T, P) = \left. \frac{\partial h}{\partial T} \right|_P = \frac{d}{dT}(h(T)) = c_P(T). \quad (3.229)$$

Separating variables in Eq. (3.229), we get then

$$dh = c_P(T) dT. \quad (3.230)$$

Now, we can differentiate Eq. (3.225) to get

$$dh = du + R dT. \quad (3.231)$$

Now, substitute Eqs. (3.228,3.230) into Eq. (3.231) to get

$$c_P(T) dT = c_v(T) dT + R dT, \quad (3.232)$$

$$c_P(T) = c_v(T) + R. \quad (3.233)$$

$$\boxed{c_P(T) - c_v(T) = R.} \quad (3.234)$$

This is sometimes known as *Mayer's relation*. Last, let us define the *ratio of specific heats*, k , as

$$k = \frac{c_P}{c_v}. \quad (3.235)$$

For general materials $k = k(T, v)$. For an ideal gas, we have

$$k = \frac{c_v(T) + R}{c_v(T)} = 1 + \frac{R}{c_v(T)}. \quad (3.236)$$

So $k = k(T)$ for an ideal gas. We will see that $k(T)$ is often nearly constant. Because $R > 0$ and $c_v(T) > 0$, we must have $k > 1$ for an ideal gas. This is also a consequence of Eq. (3.220). Later in Ch. 9.4, it will be rigorously shown for general materials.

3.8.1.1 Calorically perfect

A *calorically perfect ideal gas (CPIG)* has constant specific heat. Examples of CPIGs include noble and monatomic gases (e.g. He, Ne, Ar, O, H, N) over a wide range of temperatures and pressures, and more complex molecules (e.g. O₂, N₂, CO₂, CH₄) over narrower bands of temperatures and pressures.

For the CPIG, c_v is a constant, so

$$\left. \frac{\partial u}{\partial T} \right|_v = c_v. \quad (3.237)$$

But for the ideal gas, $u = u(T)$, so the partial derivatives become total derivatives and

$$\frac{du}{dT} = c_v. \quad (3.238)$$

Integrating, we get the simple caloric equation of state:

$$\boxed{u(T) = u_o + c_v(T - T_o)}, \quad (3.239)$$

valid for CPIG.

Note that

$$u = u_o + c_v T - c_v T_o, \quad (3.240)$$

$$\underbrace{u + Pv}_{=h} = u_o + c_v T - c_v T_o + \underbrace{Pv}_{=RT}, \quad (3.241)$$

$$h = u_o + c_v T - c_v T_o + RT, \quad (3.242)$$

$$= u_o + c_v T - c_v T_o + RT + RT_o - RT_o, \quad (3.243)$$

$$= \underbrace{u_o + RT_o}_{=h_o} + \underbrace{(c_v + R)T}_{=c_P T} - \underbrace{(c_v T_o + RT_o)}_{=c_P T_o}, \quad (3.244)$$

$$= h_o + c_P T - c_P T_o. \quad (3.245)$$

So

$$\boxed{h(T) = h_o + c_P(T - T_o)}, \quad (3.246)$$

valid for CPIG.

For a CPIG,

$$k = \frac{\bar{c}_P}{\bar{c}_v} = \frac{c_P}{c_v} = \text{constant}. \quad (3.247)$$

Example 3.22

Given Ar at $P_1 = 140$ kPa, $T_1 = 10$ °C, $V_1 = 200$ ℓ that undergoes a polytropic compression to $P_2 = 700$ kPa, $T_2 = 180$ °C, find ${}_1Q_2$.

To calculate ${}_1Q_2$, we will need to invoke the first law: $U_2 - U_1 = {}_1Q_2 - {}_1W_2$. Now, for the CPIG, we will be able to calculate ΔU from knowledge of ΔT , and we can easily compute ${}_1W_2$ from its definition as $\int_1^2 P dV$. This will let us calculate the heat transfer.

Ar is a noble gas. Because it is noble, it is well modeled as a CPIG over a wide range of temperatures., as long as it is far from the vapor dome. From Table A.5 in BS, we find the data

$$M = 39.948 \frac{\text{kg}}{\text{kmole}}, \quad R = 0.2081 \frac{\text{kJ}}{\text{kg K}}, \quad c_v = 0.312 \frac{\text{kJ}}{\text{kg K}}. \quad (3.248)$$

Note that

$$\frac{c_v}{R} = \frac{0.312 \frac{\text{kJ}}{\text{kg K}}}{0.2081 \frac{\text{kJ}}{\text{kg K}}} = 1.49928 \sim \frac{3}{2}. \quad (3.249)$$

This result will be seen to be valid for all monatomic gases, such as He, Ne, H, O, etc.

Also note that

$$MR = \left(39.948 \frac{\text{kg}}{\text{kmole}} \right) \left(0.2081 \frac{\text{kJ}}{\text{kg K}} \right) = 8.31318 \frac{\text{kJ}}{\text{kmole K}} = \bar{R}. \quad (3.250)$$

Now, we need to have absolute temperatures. Adding 273.15 to both temperatures, we get

$$T_1 = 283.15 \text{ K}, \quad T_2 = 453.15 \text{ K}. \quad (3.251)$$

Also

$$V_1 = (200 \ell) \frac{0.001 \text{ m}^3}{\ell} = 0.2 \text{ m}^3. \quad (3.252)$$

Let us compute the mass m . From one incarnation of the ideal gas law, we have

$$m = \frac{P_1 V_1}{RT_1} = \frac{(140 \text{ kPa})(0.2 \text{ m}^3)}{\left(0.2081 \frac{\text{kJ}}{\text{kg K}}\right)(283.15 \text{ K})} = 0.475192 \text{ kg}. \quad (3.253)$$

Now, at state 2, we have

$$P_2 V_2 = mRT_2, \quad (3.254)$$

$$V_2 = \frac{mRT_2}{P_2} = \frac{(0.475192 \text{ kg}) \left(0.2081 \frac{\text{kJ}}{\text{kg K}}\right) (453.15 \text{ K})}{700 \text{ kPa}} = 0.0640155 \text{ m}^3. \quad (3.255)$$

Now, for the polytropic process, we have

$$P_1 V_1^n = P_2 V_2^n, \quad (3.256)$$

$$\frac{P_1}{P_2} = \left(\frac{V_2}{V_1}\right)^n, \quad (3.257)$$

$$\ln\left(\frac{P_1}{P_2}\right) = \ln\left(\frac{V_2}{V_1}\right)^n, \quad (3.258)$$

$$= n \ln\left(\frac{V_2}{V_1}\right), \quad (3.259)$$

$$n = \frac{\ln\left(\frac{P_1}{P_2}\right)}{\ln\left(\frac{V_2}{V_1}\right)}, \quad (3.260)$$

$$= \frac{\ln\left(\frac{140 \text{ kPa}}{700 \text{ kPa}}\right)}{\ln\left(\frac{0.0640155 \text{ m}^3}{0.2 \text{ m}^3}\right)} = 1.41279. \quad (3.261)$$

We have calculated the work for a polytropic process before. Repeating, we find

$${}_1W_2 = \int_1^2 P dV = P_1 V_1^n \int_1^2 \frac{dV}{V^n} = P_1 V_1^n \left[\frac{V^{1-n}}{1-n}\right]_{V_1}^{V_2} = \frac{P_1 V_1^n}{1-n} (V_2^{1-n} - V_1^{1-n}). \quad (3.262)$$

But because $P_1 V_1^n = P_2 V_2^n$, the work reduces to simply

$${}_1W_2 = \frac{P_2 V_2 - P_1 V_1}{1-n} = \frac{(700 \text{ kPa})(0.0640155 \text{ m}^3) - (140 \text{ kPa})(0.2 \text{ m}^3)}{1-1.41279} = -40.7251 \text{ kJ}. \quad (3.263)$$

The work is negative, so the gas was worked upon in compression. Now, the first law tells us

$$U_2 - U_1 = {}_1Q_2 - {}_1W_2, \quad (3.264)$$

$${}_1Q_2 = U_2 - U_1 + {}_1W_2, \quad (3.265)$$

$$= mc_v(T_2 - T_1) + {}_1W_2, \quad (3.266)$$

$$= (0.475192 \text{ kg}) \left(0.312 \frac{\text{kJ}}{\text{kg K}}\right) ((453.15 \text{ K}) - (283.15 \text{ K})) + (-40.7251 \text{ kJ}), \quad (3.267)$$

$$= \boxed{-15.5209 \text{ kJ}}. \quad (3.268)$$

The heat transfer is negative, so heat was lost from the system, *even though the temperature went up*. The reason the temperature went up is that the internal energy was raised more by work than it lost by heat transfer. A plot of this process is given in Fig. 3.31.

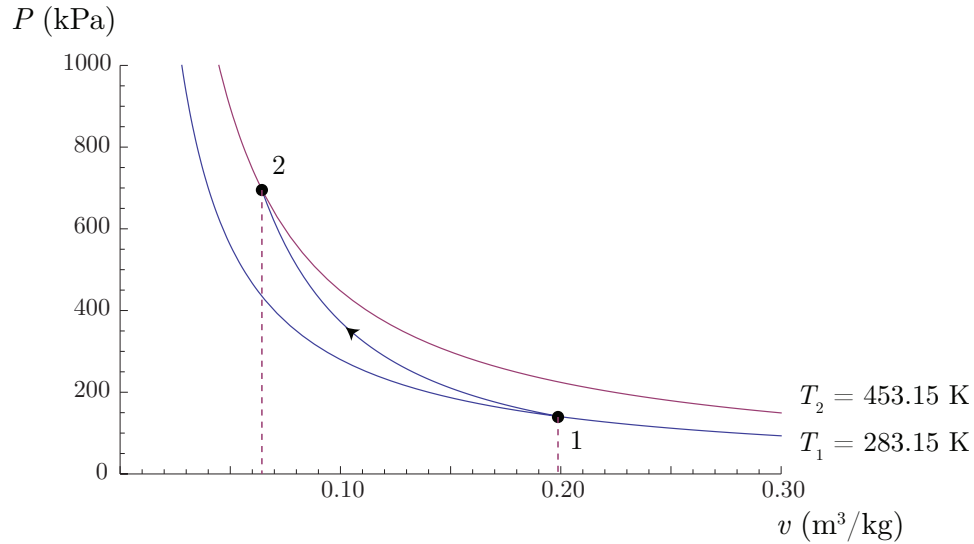

Figure 3.31: Plot of polytropic compression of Ar.

3.8.1.2 Calorically imperfect

For *calorically imperfect* ideal gases (CIIG), e.g. O_2 at moderate to high temperatures ($300\text{ K} < T < 6000\text{ K}$):

- $u = u(T)$,
- $c_v = c_v(T)$,
- $h = h(T)$,
- $c_p = c_p(T)$.

For such temperatures, our assumption of constant c_v is not as valid. But for ideal gases, we can still take $c_v = c_v(T)$, so

$$\frac{du}{dT} = c_v(T). \quad (3.269)$$

We can integrate via separation of variables to get

$$du = c_v(T) dT, \quad (3.270)$$

$$\int_1^2 du = \int_1^2 c_v(T) dT, \quad (3.271)$$

$$u_2 - u_1 = \int_1^2 c_v(T) dT. \quad (3.272)$$

We can interpret the difference in u as the area under the curve in a plot of $c_v(T)$ versus T as plotted in Fig. 3.32. More generally, we could say

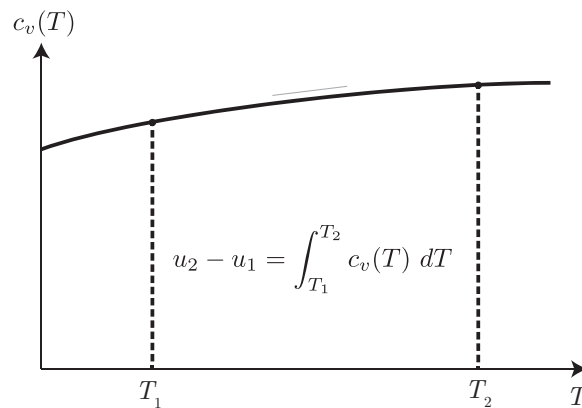

Figure 3.32: Relation between $u_2 - u_1$ and area under curve in a plot of $c_v(T)$ for calorically imperfect ideal gas.

$$u(T) = u_o + \int_{T_o}^T c_v(\hat{T}) d\hat{T}, \quad (3.273)$$

valid for all ideal gases.

Here, \hat{T} is a dummy variable of integration. Similarly, we could show

$$h_2 - h_1 = \int_{T_1}^{T_2} c_P(T) dT, \quad (3.274)$$

and more generally,

$$h(T) = h_o + \int_{T_o}^T c_P(\hat{T}) d\hat{T}, \quad (3.275)$$

valid for all ideal gases.

Now, c_v , c_P and R all have units of kJ/kg/K. Let us consider the ratio

$$\frac{c_v}{R} = \frac{c_v M}{R M} = \frac{\bar{c}_v}{\bar{R}} = \bar{\bar{c}}_v. \quad (3.276)$$

The ratio is now in terms of molar specific properties with \bar{c}_v and \bar{R} having units of kJ/kmole/K. Note that \bar{R} is the universal gas constant. A plot of \bar{c}_v/\bar{R} versus T for a variety of simple molecules is given in Fig. 3.33. We note some remarkable facts:

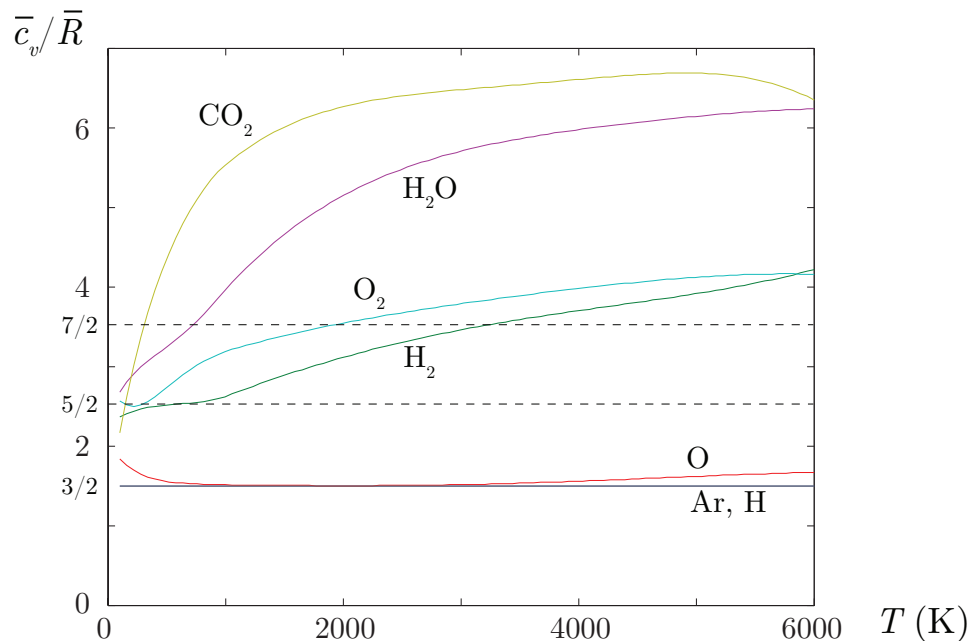

Figure 3.33: \bar{c}_v/\bar{R} as a function of T for several molecules.

- For monatomic gases, such as Ar, O, and H, $\bar{c}_v/\bar{R} = 3/2$ for a wide variety of temperatures.
- For diatomic gases, such as O₂ and H₂ for $T < 600$ K, $\bar{c}_v/\bar{R} \sim 5/2$, and for $T > 600$ K, $\bar{c}_v/\bar{R} \rightarrow 7/2$.
- For larger molecules such as CO₂ or H₂O, \bar{c}_v/\bar{R} is larger still.

What we are seeing actually reflects some fundamental physics. We first note that statistical thermodynamics proves

- *Temperature is a measure of the average translational kinetic energy of a set of molecules.*

Now, we consider some features of Fig. 3.33.

- Monatomic molecules, such as Ar, O or H have three fundamental modes of kinetic energy: translation in the x , y , and z directions. Each mode contributes $1/2$ to \bar{c}_v/\bar{R} , that sums to $3/2$.
- For diatomic molecules, we summarize the behavior in the sketch given in Fig. 3.34.

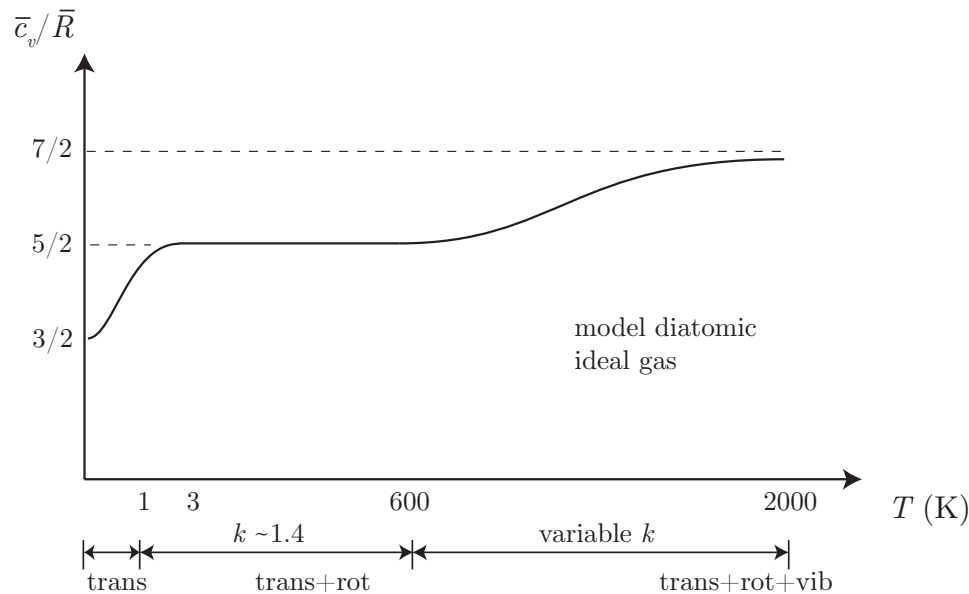

Figure 3.34: \bar{c}_v/\bar{R} as a function of T for a model diatomic gas. (Note a real gas would liquefy in the very low temperature region of the plot! So this model is really for a non-existent gas that has no liquid-inducing intermolecular forces.)

- At very low temperatures, diatomic molecules, such as H_2 or O_2 , act like monatomic molecules.
 - At low temperatures, diatomic molecules begin to rotate, and the rotational energy becomes an important component. In fact when energy is added to diatomic molecules, some is partitioned to translation and some is partitioned to rotation. There are two non-trivial axes of rotation, each adding $1/2$ to \bar{c}_v/\bar{R} , giving $\bar{c}_v/\bar{R} \sim 5/2$.
 - At higher temperatures, diatomic molecules begin to vibrate as well, and this energy becomes an important component. There are two vibrational modes, one for kinetic energy and one for potential energy. Each adds another $1/2$ to \bar{c}_v/\bar{R} , giving $\bar{c}_v/\bar{R} \sim 7/2$ at high temperature.
 - At higher temperatures still, the diatomic molecules begin to dissociate, e.g. $\text{O}_2 + \text{O}_2 \rightarrow 2\text{O} + \text{O}_2$.
 - At even higher temperatures, its electrons are stripped, and it becomes an ionized plasma. This is important in engineering applications ranging from welding to atmospheric re-entry vehicles.
- For triatomic molecules such as H_2O or CO_2 , there are more modes of motion that can absorb energy, so the specific heat is higher still.

The dissociation and ionization behavior of the components of air is clearly displayed in Fig. 3.35. Here we see at low temperatures, $T < 1000$ K, diatomic N_2 and O_2 are dominant

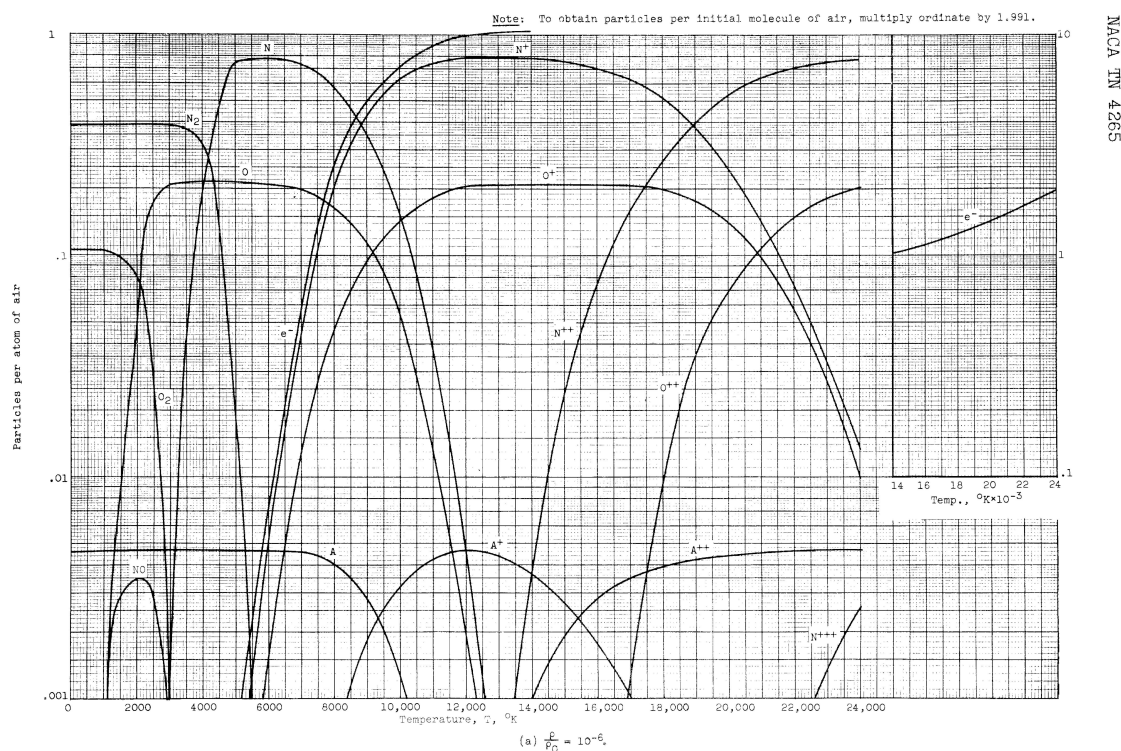

Figure 1. - Equilibrium composition of air to 24,000° K.

Figure 3.35: Equilibrium composition of air at low density and various temperatures. Figure from W. E. Moekel and K. C. Weston, 1958, *Composition and thermodynamic properties of air in chemical equilibrium*, NACA Technical Note 4265.

in air. Both of these major components begin to dissociate at higher temperatures. For $T > 6000$ K, we no longer find diatomic N_2 and O_2 , but instead find their monatomic components N and O . At higher temperatures still, the molecule loses electrons, and positive ions remain.

Feynman¹⁴ summarizes the argument that this preference for one type of energy over another (translation, rotational, vibrational) depending on temperature is surprising to those not versed in quantum mechanics and violates standard assumptions of classical statistical mechanics. In fact, he notes that Maxwell had a hint of the problem as early as 1859, and stated this concern more directly in 1869. Maxwell summarized those concerns in an 1875 lecture, transcribed in *Nature*.¹⁵ Feynman argues that the reason for the energy partition observed in diatomic gases is a “failure of classical physics” and instead is a pure effect of quantum mechanics; that is to say $k = c_P(T)/c_v(T) = k(T)$ is a non-classical result!

¹⁴R. P. Feynman, R. B. Leighton, and M. Sands, 1963, *The Feynman Lectures on Physics*, Volume 1, Addison-Wesley, Reading, Massachusetts, pp. 40-7–40-10.

¹⁵J. C. Maxwell, 1875, “On the dynamical evidence of the molecular constitution of bodies,” *Nature*, 11(280): 374-377.

Employment of the theories of quantum and statistical mechanics allows an accounting for the observation that there is a preference of molecules to exist in lower energy states, and at those states, the discrete quantization is important. High energy vibrational states are less likely than translational states at low temperature. At higher temperature, there is a higher probability that all states are populated, and one recovers results consistent with classical physics.

Let us also recall that $c_P(T) - c_v(T) = R$; thus, $\bar{c}_P(T) - \bar{c}_v(T) = \bar{R}$. Let us summarize

- for monatomic gases,

$$c_v = \frac{3}{2}R, \quad (3.277)$$

$$c_P = c_v + R = \frac{5}{2}R, \quad (3.278)$$

$$\frac{c_P}{c_v} = k = \frac{\frac{5}{2}R}{\frac{3}{2}R} = \frac{5}{3} = 1.6667. \quad (3.279)$$

- for diatomic gases at moderate temperature, $50 \text{ K} < T < 600 \text{ K}$,

$$c_v = \frac{5}{2}R, \quad (3.280)$$

$$c_P = c_v + R = \frac{7}{2}R, \quad (3.281)$$

$$\frac{c_P}{c_v} = k = \frac{\frac{7}{2}R}{\frac{5}{2}R} = \frac{7}{5} = 1.4. \quad (3.282)$$

To summarize, usually the most problematic case is whether or not specific heats vary with temperature in ideal gases. For low temperatures, the specific heat is well modeled as a constant; here the internal energy change is strictly proportional to the temperature change. For moderate to high temperatures, a temperature-variation of the specific heat is observed. Changes in internal energy are no longer strictly proportional to changes in temperature. The behavior is analogous to solid mechanics. At low strain ϵ , stress σ is proportional to strain, and the constant of proportionality is the modulus of elasticity E . For high strains, the linearity is lost; we could say the elastic modulus becomes a function of strain. We give a sketch in Fig. 3.36 of the comparison to solid mechanics

There are four main ways to calculate changes in enthalpy for ideal gases:

- assumption of constant c_P evaluated at 298 K,
- assumption of constant c_P evaluated at an intermediate temperature,
- using a known analytic form of $c_P(T)$ in the direct integration of $\int_1^2 c_P(T) dT$, or
- estimation using the ideal gas tables.

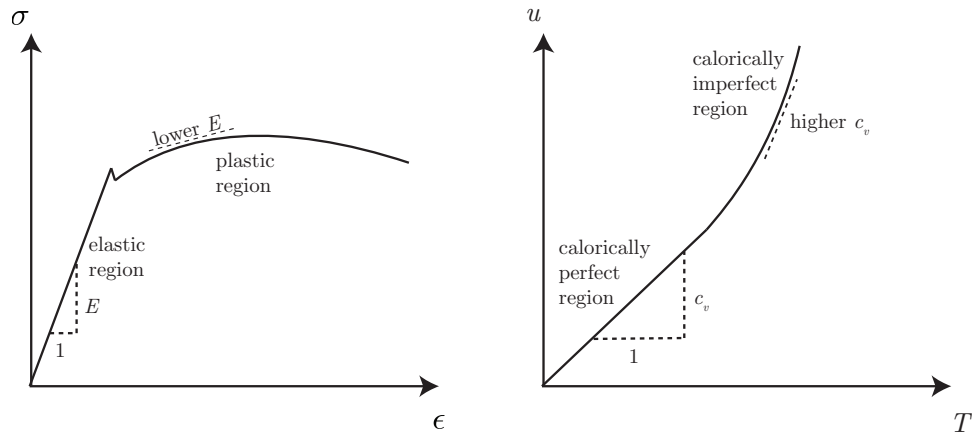

Figure 3.36: Sketch of comparison of stress-strain behavior in solids with ideal gas internal energy-temperature behavior.

Example 3.23

Calculate the heat transferred per unit mass to N_2 in an isobaric process that starts at $T_1 = 300$ K and finishes at $T_2 = 1000$ K. Use the four different means of calculating enthalpy changes to estimate the heat transfer.

The first law on a per mass basis gives

$$u_2 - u_1 = {}_1q_2 - {}_1w_2. \quad (3.283)$$

For an isobaric process, ${}_1w_2 = \int_1^2 P \, dv = P(v_2 - v_1) = P_2v_2 - P_1v_1$. So

$${}_1q_2 = u_2 - u_1 + P_2v_2 - P_1v_1 = h_2 - h_1 = \Delta h = \int_1^2 c_P(T) \, dT. \quad (3.284)$$

- *Constant c_P at 298 K.* From Table A.5 in BS, we find $c_P = 1.042$ kJ/kg/K. Thus, we estimate

$$\Delta h = h_2 - h_1 = c_P(T_2 - T_1) = \left(1.042 \frac{\text{kJ}}{\text{kg K}}\right) ((1000 \text{ K}) - (300 \text{ K})) = \boxed{729.4 \frac{\text{kJ}}{\text{kg}}}. \quad (3.285)$$

- *Constant c_P at the average temperature.* The average temperature is

$$T_{ave} = \frac{T_1 + T_2}{2} = \frac{300 \text{ K} + 1000 \text{ K}}{2} = 650 \text{ K}. \quad (3.286)$$

Table A.6 in BS has polynomial curve fits for c_P . For N_2 , we find from Table A.6 that

$$c_P = C_0 + C_1\theta + C_2\theta^2 + C_3\theta^3, \quad \theta \equiv \frac{T}{1000 \text{ K}}. \quad (3.287)$$

The numbers C_0, \dots, C_3 actually have units and are designed to yield a value for c_P in kJ/kg/K. We

get

$$c_P = \left(1.11 \frac{\text{kJ}}{\text{kg K}}\right) - \left(0.48 \frac{\text{kJ}}{\text{kg K}}\right) \left(\frac{T}{1000 \text{ K}}\right) + \left(0.96 \frac{\text{kJ}}{\text{kg K}}\right) \left(\frac{T}{1000 \text{ K}}\right)^2 - \left(0.42 \frac{\text{kJ}}{\text{kg K}}\right) \left(\frac{T}{1000 \text{ K}}\right)^3, \quad (3.288)$$

$$= \left(1.11 \frac{\text{kJ}}{\text{kg K}}\right) - \left(0.48 \frac{\text{kJ}}{\text{kg K}}\right) \left(\frac{650 \text{ K}}{1000 \text{ K}}\right) + \left(0.96 \frac{\text{kJ}}{\text{kg K}}\right) \left(\frac{650 \text{ K}}{1000 \text{ K}}\right)^2 - \left(0.42 \frac{\text{kJ}}{\text{kg K}}\right) \left(\frac{650 \text{ K}}{1000 \text{ K}}\right)^3, \quad (3.289)$$

$$= 1.08826 \frac{\text{kJ}}{\text{kg K}}. \quad (3.290)$$

So the improved prediction of the enthalpy change is

$$\Delta h = c_P(T_2 - T_1) = \left(1.08826 \frac{\text{kJ}}{\text{kg K}}\right) ((1000 \text{ K}) - (300 \text{ K})) = \boxed{761.78 \frac{\text{kJ}}{\text{kg}}}. \quad (3.291)$$

- *Direct integration.* We know

$$\Delta h = h_2 - h_1 = \int_{T_1}^{T_2} c_P(T) dT. \quad (3.292)$$

Let us change variables from T to θ . We have $\theta = T/(1000 \text{ K})$, so $d\theta = dT/(1000 \text{ K})$, and $dT = (1000 \text{ K}) d\theta$. Thus,

$$\Delta h = \int_{\theta_1}^{\theta_2} (C_0 + C_1\theta + C_2\theta^2 + C_3\theta^3) ((1000 \text{ K}) d\theta), \quad (3.293)$$

$$= (1000 \text{ K}) \left[C_0\theta + C_1\frac{\theta^2}{2} + C_2\frac{\theta^3}{3} + C_3\frac{\theta^4}{4} \right]_{\theta_1}^{\theta_2}, \quad (3.294)$$

$$= (1000 \text{ K}) \left[\left(1.11 \frac{\text{kJ}}{\text{kg K}}\right) \theta - \left(0.48 \frac{\text{kJ}}{\text{kg K}}\right) \frac{\theta^2}{2} + \left(0.96 \frac{\text{kJ}}{\text{kg K}}\right) \frac{\theta^3}{3} - \left(0.42 \frac{\text{kJ}}{\text{kg K}}\right) \frac{\theta^4}{4} \right]_{\frac{300 \text{ K}}{1000 \text{ K}}}^{\frac{1000 \text{ K}}{1000 \text{ K}}}. \quad (3.295)$$

The final value is

$$\Delta h = \boxed{765.81 \frac{\text{kJ}}{\text{kg}}}. \quad (3.296)$$

- *Use of ideal gas tables.* Lastly, we can use the ideal gas tables. For us, Table A.8 of BS is best. We find $h(300 \text{ K}) = 311.67 \text{ kJ/kg}$ and $h(1000 \text{ K}) = 1075.91 \text{ kJ/kg}$. So

$$\Delta h = h_2 - h_1 = \left(1075.91 \frac{\text{kJ}}{\text{kg}}\right) - \left(311.67 \frac{\text{kJ}}{\text{kg}}\right) = \boxed{764.24 \frac{\text{kJ}}{\text{kg}}}. \quad (3.297)$$

Example 3.24

A calorically imperfect ideal gas is known to have

$$c_P(T) = c_{P_o} + aT. \quad (3.298)$$

A sample of this gas begins at P_1, T_1 . It is heated isobarically to T_2 , and expanded isochorically to T_3 . Find the change in internal energy of the gas, $u_3 - u_1$.

Because internal energy changes are path-independent, we need not worry about any details of the process, including its path. That is because we know the end states. So we can use a version of Eq. (3.272) to get

$$u_3 - u_1 = \int_{T_1}^{T_3} c_v(T) dT. \quad (3.299)$$

We are given c_P , but need c_v . We can use Mayer's relation, Eq. (3.234) to get

$$c_v(T) = c_P(T) - R = (c_{P_o} - R) + aT. \quad (3.300)$$

So

$$u_3 - u_1 = \int_{T_1}^{T_3} \underbrace{((c_{P_o} - R) + aT)}_{c_v(T)} dT. \quad (3.301)$$

Integrating, we find

$$u_3 - u_1 = (c_{P_o} - R)(T_3 - T_1) + \frac{a}{2}(T_3^2 - T_1^2). \quad (3.302)$$

Had we been asked to find the heat transfer, ${}_1Q_3$, we would have had to calculate the work ${}_1W_3$, and the details of the path would have been required. Because internal energy is a state function, only the end states are required to evaluate the change in internal energy.

3.8.2 Liquids and solids

Most liquids and solids for moderate pressures or below, $P < 1$ GPa, are well modeled as incompressible. For such materials, we have caloric equations of state and specific heats of the form

- $u = u(T)$,
- $c = c(T)$.

For such a material

$$u(T) = u_o + \int_{T_o}^T c(\hat{T}) d\hat{T}, \quad (3.303)$$

and

$$\frac{du}{dT} = c(T). \quad (3.304)$$

Often, we can take a calorically perfect model in which c loses its temperature variation, and get the commonly used equations

$$u(T) = u_o + c(T - T_o), \quad (3.305)$$

$$\frac{du}{dT} = c. \quad (3.306)$$

Example 3.25

A mass of cast iron of $m = 1$ kg is heated from $T_1 = 300$ K to $T_2 = 400$ K. Determine the thermal energy required.

The first law is

$$U_2 - U_1 = {}_1Q_2 - {}_1W_2. \quad (3.307)$$

Incompressible solids have effectively zero work, so

$$U_2 - U_1 = {}_1Q_2. \quad (3.308)$$

On a per mass basis, we have

$${}_1Q_2 = m(u_2 - u_1). \quad (3.309)$$

Now, invoke the caloric equation of state for the solid, $u_2 - u_1 = c(T_2 - T_1)$, to get

$${}_1Q_2 = mc(T_2 - T_1). \quad (3.310)$$

For cast iron, Table A.3 of BS tells us $c = 0.42$ kJ/kg/K, so

$${}_1Q_2 = (1 \text{ kg}) \left(0.42 \frac{\text{kJ}}{\text{kg K}} \right) ((400 \text{ K}) - (300 \text{ K})) = 42 \text{ kJ}. \quad (3.311)$$

Example 3.26

A tall thermally insulated shaft contains 100 kg of water at its base at 20 °C. At the top of the shaft, at $z = 100$ m, is a 5 kg mass of aluminum, also at 20 °C. The mass is dropped to the base, comes to rest, and comes to equilibrium with the water. Local $g = 9.81$ m/s². Find the final temperature. A sketch of this process is given in Fig. 3.37.

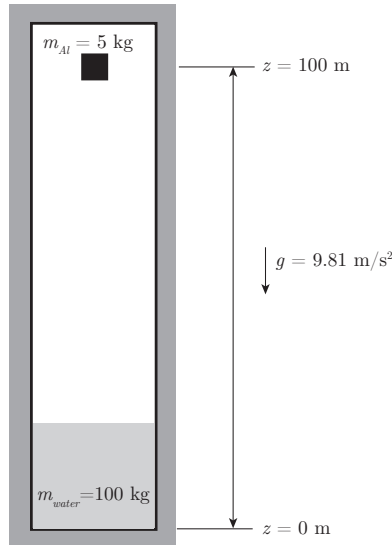

Figure 3.37: Sketch of potential to thermal energy conversion problem.

We can consider the masses of the water and the aluminum to constitute our combined system. The combined system is isolated; that is there is no heat or work crossing the system boundary. We cannot neglect mechanical energy in this problem. So the first law is

$$E_2 - E_1 = \underbrace{{}_1Q_2 - {}_1W_2}_{=0}, \quad (3.312)$$

$$E_2 - E_1 = 0, \quad (3.313)$$

$$\left(U_2 + \underbrace{KE_2}_{=0} + PE_2 \right) - \left(U_1 + \underbrace{KE_1}_{=0} + PE_1 \right) = 0. \quad (3.314)$$

Now, at the beginning and end of the process neither water nor aluminum is in motion; hence, $KE_1 = KE_2 = 0$. So

$$(U_2 - U_1) + \underbrace{(PE_2 - PE_1)}_{=0} = 0. \quad (3.315)$$

Now, at state 2, neither mass retains any potential energy, so

$$U_2 - U_1 = PE_1. \quad (3.316)$$

Now, U represents an extensive energy of the combined system. And we have two components. The total is the sum of the parts, that leads to

$$m_{water}c_{water}(T_2 - T_1) + m_{Al}c_{Al}(T_2 - T_1) = m_{Al}gH. \quad (3.317)$$

Solve for T_2 and get

$$T_2 = T_1 + \frac{m_{Al}gH}{m_{water}c_{water} + m_{Al}c_{Al}}. \quad (3.318)$$

Take data for c from Tables A.3,4 of BS and get

$$T_2 = (20 \text{ }^\circ\text{C}) + \frac{(5 \text{ kg}) (9.81 \frac{\text{m}}{\text{s}^2}) (100 \text{ m}) (\frac{\text{kJ}}{1000 \text{ J}})}{(100 \text{ kg}) (4.18 \frac{\text{kJ}}{\text{kg K}}) + (5 \text{ kg}) (0.90 \frac{\text{kJ}}{\text{kg K}})} = 20.0116 \text{ }^\circ\text{C}. \quad (3.319)$$

Note because we are dealing with temperature differences, K plays the same role as °C, and there is no need to transform.

3.8.3 General materials

Examples of general materials include water and van der Waals gases. For such materials we have caloric equations of state and specific heats

- $u = u(T, v)$,
- $c_v = c_v(T, v)$,
- $h = h(T, P)$,
- $c_P = c_P(T, P)$.

A sketch of an estimate for $u(T, v)$ and $c_v(T, v)$ for superheated water is given in Fig. 3.38. Here, we selected a Redlich-Kwong model obeying

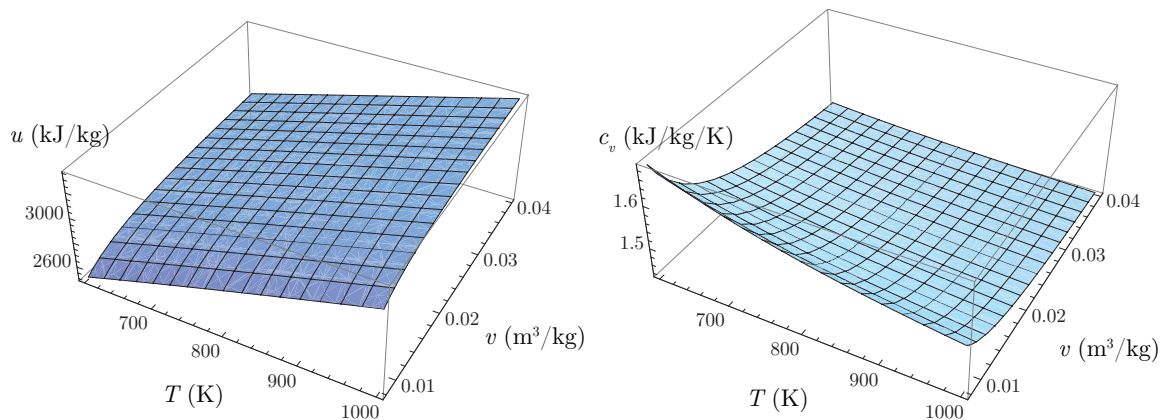

Figure 3.38: Sketch of $u = u(T, v)$, $c_v = c_v(T, v)$ using a Redlich-Kwong caloric state equation model for superheated water.

$$u(T, v) = \left(2863.75 \frac{\text{kJ}}{\text{kg}} \right) + \left(1.41 \frac{\text{kJ}}{\text{kg K}} \right) (T - (673.15 \text{ K})) - \left(65.743 \frac{\text{kJ K}^{1/2} \text{m}^3}{\text{kg}} \right) \left(\left(1.12304 \frac{\text{kg}}{\text{K}^{1/2} \text{m}^3} \right) - \frac{1}{\sqrt{Tv}} \right), \quad (3.320)$$

$$c_v(T, v) = \left(1.41 \frac{\text{kJ}}{\text{kg K}} \right) + \frac{\left(32.8715 \frac{\text{kJ K}^{1/2} \text{m}^3}{\text{kg}} \right)}{T^{3/2} v}. \quad (3.321)$$

This particular model ignores some of the potential temperature variation of c_v , but is useful for illustration purposes. It gives results not unlike those in portions of the steam tables. As an aside, the Redlich-Kwong thermal equation of state, see p. 63, for superheated water is

$$P = \frac{\left(0.461504 \frac{\text{kJ}}{\text{kg K}}\right) T}{v - \left(0.00117008 \frac{\text{m}^3}{\text{kg}}\right)} - \frac{43.8287 \frac{\text{kJ}}{\text{kg}} \frac{\text{K}^{1/2} \text{m}^3}{\text{kg}}}{v \left(v + \left(0.00117008 \frac{\text{m}^3}{\text{kg}}\right)\right) \sqrt{T}}. \quad (3.322)$$

Even more generally, u and h are tabulated for materials such as water.

Example 3.27

Consider water in a fixed total volume of $V = 5 \text{ m}^3$. Initially there is $V_f = 0.05 \text{ m}^3$ of liquid water and $V_g = 4.95 \text{ m}^3$ of water vapor. The initial pressure is $P_1 = 100 \text{ kPa}$. Heat is added isochorically until the saturated vapor state is reached. Determine ${}_1Q_2$.

A sketch of this process is given in Fig. 3.39. The first law tells us

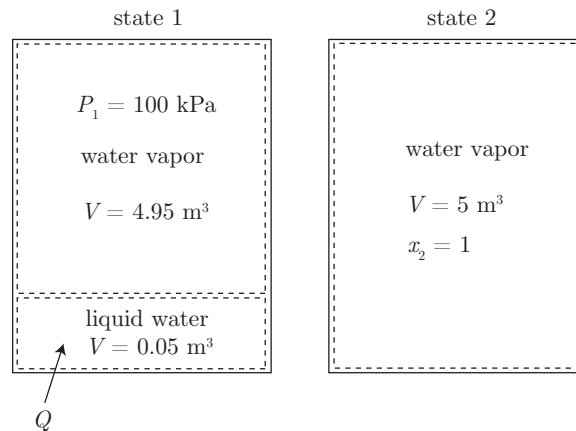

Figure 3.39: Sketch of isochoric water heating problem.

$$U_2 - U_1 = {}_1Q_2 - \underbrace{{}_1W_2}_{=0}. \quad (3.323)$$

Because the process is isochoric, the work is zero. So

$${}_1Q_2 = U_2 - U_1, \quad (3.324)$$

$$= m(u_2 - u_1). \quad (3.325)$$

So, we need to find u_1 and u_2 from caloric equations of state to solve this problem. Here, however, our equations reside in tabular form. Let us see what we know. At state 1, we have $P_1 = 100 \text{ kPa}$. We need another property to fix state 1. We can get the quality, x_1 , by the following analysis. First, we know that state 1 is a two-phase mixture. The saturated water tables tell us

$$T_1 = 99.62 \text{ }^\circ\text{C}, \quad v_f = 0.001043 \frac{\text{m}^3}{\text{kg}}, \quad v_g = 1.69400 \frac{\text{m}^3}{\text{kg}}. \quad (3.326)$$

So we get at state 1

$$m_f = \frac{V_f}{v_f} = \frac{0.05 \text{ m}^3}{0.001043 \frac{\text{m}^3}{\text{kg}}} = 47.9386 \text{ kg}, \quad (3.327)$$

$$m_g = \frac{V_g}{v_g} = \frac{4.95 \text{ m}^3}{1.694 \frac{\text{m}^3}{\text{kg}}} = 2.92208 \text{ kg}. \quad (3.328)$$

So the total mass is

$$m = m_f + m_g = (47.9386 \text{ kg}) + (2.92208 \text{ kg}) = 50.8607 \text{ kg}. \quad (3.329)$$

So the quality at state 1 is

$$x_1 = \frac{m_g}{m} = \frac{2.92208 \text{ kg}}{50.8607 \text{ kg}} = 0.0574526. \quad (3.330)$$

So we get

$$v_1 = \frac{V}{m} = \frac{5 \text{ m}^3}{50.8607 \text{ kg}} = 0.0983077 \frac{\text{m}^3}{\text{kg}}. \quad (3.331)$$

Now, for the internal energy at state 1, we can say

$$u_1 = u_f + x_1 u_{fg}. \quad (3.332)$$

We find u_f and u_g from the saturated water tables, Table B.1.2 of BS, giving us

$$u_1 = \left(417.33 \frac{\text{kJ}}{\text{kg}}\right) + (0.0574526) \left(2088.72 \frac{\text{kJ}}{\text{kg}}\right) = 537.332 \frac{\text{kJ}}{\text{kg}}. \quad (3.333)$$

At state 2, we know that $v_2 = v_1 = 0.0983077 \text{ m}^3/\text{kg}$. We also know that $x_2 = 1$, because we were told in the problem statement the final state was saturated vapor. We interpolate Table B.1.2 of BS between $P = 2000 \text{ kPa}$ and $P = 2250 \text{ kPa}$ to find

$$u_2 = \left(2600.26 \frac{\text{kJ}}{\text{kg}}\right) + \left(\frac{\left(2601.98 \frac{\text{kJ}}{\text{kg}}\right) - \left(2600.26 \frac{\text{kJ}}{\text{kg}}\right)}{\left(0.08875 \frac{\text{m}^3}{\text{kg}}\right) - \left(0.09963 \frac{\text{m}^3}{\text{kg}}\right)}\right) \times \left(\left(0.0983077 \frac{\text{m}^3}{\text{kg}}\right) - \left(0.09963 \frac{\text{m}^3}{\text{kg}}\right)\right), \quad (3.334)$$

$$= 2600.47 \frac{\text{kJ}}{\text{kg}}. \quad (3.335)$$

So the heat transfer is

$${}_1Q_2 = m(u_2 - u_1) = (50.8607 \text{ kg}) \left(\left(2600.47 \frac{\text{kJ}}{\text{kg}}\right) - \left(537.332 \frac{\text{kJ}}{\text{kg}}\right)\right) = \boxed{104993 \text{ kJ}}. \quad (3.336)$$

One could also interpolate for the final pressure and temperature and find them to be $P_2 = 2030.38 \text{ kPa}$, and $T_2 = 213.153 \text{ }^\circ\text{C}$. Sketches of this process are given in Fig. 3.40.

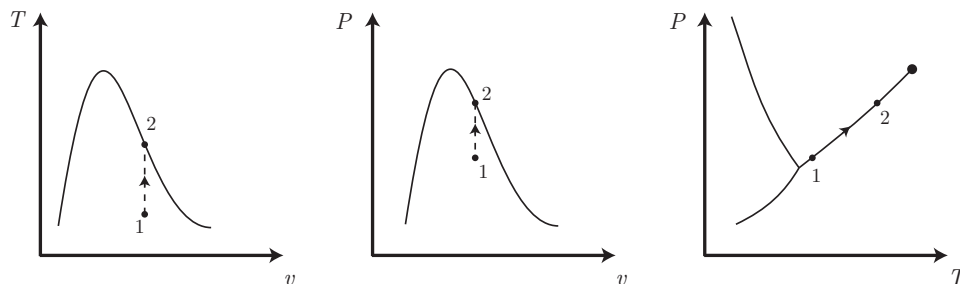

Figure 3.40: Sketches of process of isochoric water heating problem in various planes.

3.9 Time-dependency

We venture gently away from classical thermodynamics into non-equilibrium thermodynamics. Let us admit time t into the differential form of the first law by scaling Eq. (3.165) by dt :

$$\frac{dU}{dt} + \frac{d}{dt}(KE) + \frac{d}{dt}(PE) = \frac{\delta Q}{dt} - \frac{\delta W}{dt}. \quad (3.337)$$

Because total energy $E = U + KE + PE$, we could also say

$$\frac{dE}{dt} = \frac{\delta Q}{dt} - \frac{\delta W}{dt}. \quad (3.338)$$

Often, we will use the Newtonian “dot” notation for time derivatives. A common form is

$$\boxed{\frac{dE}{dt} = \dot{Q} - \dot{W}.} \quad (3.339)$$

In this course, we will often neglect changes in KE and PE , in which case the time-dependent first law reduces to

$$\boxed{\frac{dU}{dt} = \dot{Q} - \dot{W}.} \quad (3.340)$$

Many times in this course, we will treat \dot{Q} and \dot{W} as constants. Problems become more interesting when they are variable. Such problems are also important. Now, Newton did consider some thermal problems. In fact Newton’s law of cooling (see Eq. (3.147)) tells us that \dot{Q} is proportional to the surface area of a body and the temperature difference between the body and its environment:

$$\dot{Q} = -hA(T - T_\infty). \quad (3.341)$$

Note that heat flows into a body when it has a temperature less than its surroundings, $T < T_\infty$. Here, we have the

- HEAT TRANSFER COEFFICIENT, h , with units $\text{W}/\text{m}^2/\text{K}$.

Note $h \neq h$. Enthalpy is a different physical quantity with different units. While Eq. (3.341) is given the elevated name of “law,” one must realize that it is by no means a law of the same status as the first law of thermodynamics. Rather, it is actually only a useful but fallible approximation; often h is not a constant but rather a complicated function of the local material’s state and geometrical configuration. Its nuances are the subject of the discipline of convective heat transfer.

Example 3.28

Use Newton’s law of cooling along with the first law of thermodynamics and a caloric state equation to estimate the time necessary to bake a potato. See Fig. 3.41 showing a potato in a modern convection oven.



Figure 3.41: Unbaked potato in a convection oven, $t = 0$ min.

Let us describe the potato as a sphere with surface area A , volume V , temperature T , density ρ , initial temperature T_o , immersed in an oven at constant T_∞ . The first law tells us that

$$\frac{dU}{dt} = \dot{Q} - \dot{W}. \quad (3.342)$$

We can take $\dot{W} = 0$ because of incompressibility, so

$$\frac{dU}{dt} = \dot{Q}. \quad (3.343)$$

Now, the caloric state equation is $U = U_o + mc(T - T_o)$. Take c constant, so $dU/dt = mc(dT/dt)$; thus, the first law becomes

$$mc \frac{dT}{dt} = \dot{Q}. \quad (3.344)$$

Now, invoke Newton’s law of cooling to get

$$mc \frac{dT}{dt} = -hA(T - T_\infty). \quad (3.345)$$

Now, $m = \rho V$, so

$$\rho V c \frac{dT}{dt} = -hA(T - T_\infty). \quad (3.346)$$

So

$$\frac{dT}{dt} = -\frac{hA}{\rho c V}(T - T_\infty). \quad (3.347)$$

Now, this is a first order ordinary differential equation for $T(t)$. We can separate variables to get

$$\frac{dT}{T - T_\infty} = -\frac{hA}{\rho c V} dt, \quad (3.348)$$

$$\int \frac{dT}{T - T_\infty} = \int -\frac{hA}{\rho c V} dt, \quad (3.349)$$

$$\ln(T - T_\infty) = -\frac{hA}{\rho c V}t + C, \quad (3.350)$$

$$T - T_\infty = C' \exp\left(-\frac{hA}{\rho c V}t\right). \quad (3.351)$$

Here, $C' = \exp(C)$ and is also a constant. Now, when $t = 0$, we have $T = T_o$, so

$$T_o - T_\infty = C' \underbrace{\exp\left(-\frac{hA}{\rho c V}0\right)}_{=1}, \quad (3.352)$$

$$= C'. \quad (3.353)$$

Thus

$$T(t) = T_\infty + (T_o - T_\infty) \exp\left(-\frac{hA}{\rho c V}t\right). \quad (3.354)$$

Notice that $T(0) = T_o$ and $T(\infty) = T_\infty$. And notice that when the argument of the exponential is -1 , giving $\exp(-1) = 0.357$, we get a good estimate of the time it takes to get most of the way to equilibrium. We define this as the *time constant*, τ of the system. Here, we can get τ via

$$-\frac{hA}{\rho c V}\tau = -1, \quad (3.355)$$

$$\tau = \frac{\rho c V}{hA}. \quad (3.356)$$

So we get fast cooking (small τ) if

- ρ is small (a light potato),
- c is small,
- h is large (the heat transfer rate is fast), or
- A/V is large (the surface to volume ratio is large).

For our potato, let us model it as a sphere of liquid water with $R = 0.05$ m, $\rho = 997$ kg/m³, $c = 4.18$ kJ/kg/K. Let us take $h = 0.012$ kW/m²/K. Let us take $T_o = 20$ °C, $T_\infty = 200$ °C. For a sphere, we have the surface to volume ratio of

$$\frac{A}{V} = \frac{4\pi R^2}{(4/3)\pi R^3} = \frac{3}{R}. \quad (3.357)$$

With this the time constant τ is

$$\tau = \frac{\rho c R}{3h}. \quad (3.358)$$

Small radius leads to fast cooking. Our temperature varies with time as

$$T(t) = T_\infty + (T_o - T_\infty) \exp\left(-\frac{3h}{\rho c R} t\right), \quad (3.359)$$

$$= (200 \text{ }^\circ\text{C}) + ((20 \text{ }^\circ\text{C}) - (200 \text{ }^\circ\text{C})) \exp\left(-\frac{3 (0.012 \frac{\text{kW}}{\text{m}^2 \text{K}})}{\left(997 \frac{\text{kg}}{\text{m}^3}\right) \left(4.18 \frac{\text{kJ}}{\text{kg K}}\right) (0.05 \text{ m})} t\right), \quad (3.360)$$

$$= (200 \text{ }^\circ\text{C}) - (180 \text{ }^\circ\text{C}) \exp\left(\frac{-t}{5788.14 \text{ s}}\right). \quad (3.361)$$

The time constant $\tau = 5788.14 \text{ s} = 96.469 \text{ min}$. When $T = 100 \text{ }^\circ\text{C}$, the potato is probably cooked enough. This occurs at

$$t = (3402.19 \text{ s}) \left(\frac{\text{min}}{60 \text{ s}}\right) = 56.7032 \text{ min}. \quad (3.362)$$

If we leave the potato in the oven too long, it will get too hot, and all its water will boil away. Note that our simple analysis does not account for latent heat and mass loss of vaporization. The temperature history is plotted in Fig. 3.42.

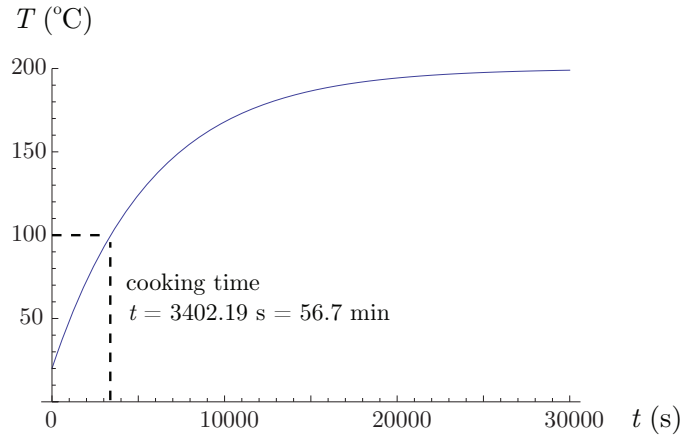

Figure 3.42: Temperature versus time for the potato in the oven.

This example used what is known as the *lumped capacitance method* for analysis of $T(t)$. In actuality, T is a function of space and time: $T = T(x, y, z, t)$. It will be shown in later courses that the lumped capacitance method is valid when the so-called *Biot number*, Bi , is much less than unity. Biot himself was an important physicist who played a small role in thermal sciences. He is depicted in Fig. 3.43. The Biot number for our potato problem is defined as

$$Bi \equiv \frac{hR}{k}, \quad (3.363)$$

where k is the thermal conductivity. For the lumped capacitance to be valid, we need

$$Bi = \frac{hR}{k} \ll 1, \quad \text{thus} \quad k \gg hR. \quad (3.364)$$



Figure 3.43: Jean-Baptiste Biot (1774-1862). French physicist, astronomer, and mathematician. Image from https://en.wikipedia.org/wiki/Jean_Baptiste_Biot.

For liquid water, $k \sim 0.006 \text{ kW/m/K}$, so for this problem

$$Bi = \frac{(0.012 \frac{\text{kW}}{\text{m}^2 \text{K}}) (0.05 \text{ m})}{0.006 \frac{\text{kW}}{\text{m K}}} = 0.1. \quad (3.365)$$

This is a small enough Biot number that our lumped capacitance method is acceptable. Physically, if the thermal conductivity is high relative to the product of h and R , thermal energy diffuses rapidly in the solid, and internal temperature gradients are small.

The predictions of this theory were tested in a domestic laboratory. The specimen of Fig. 3.41 was subjected to the culinary regimen suggested by the analysis: 57 min at 200 °C in a convection oven. The results can be seen in Fig. 3.44. Qualitative testing by a human subject following treatment with

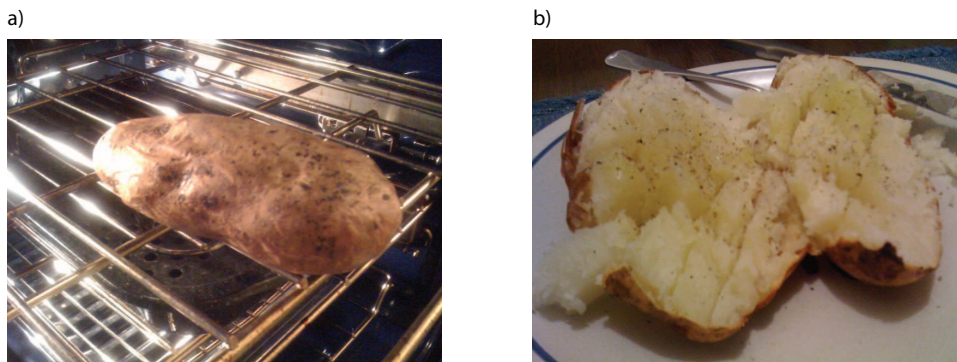

Figure 3.44: a) Baked potato following an oven-based heat transfer process, $t = 57 \text{ min}$; b) the same potato subjected to a routine post-heating, pre-human-ingestion mashing and seasoning procedure.

NaCl, ground black pepper, and bovine butter revealed the potato induced a high degree of gastronomic satisfaction.

Let us consider an excursion into thermochemistry in which exothermic reaction plays a role. This will provide a mathematical model that can be shown to model to growth and decay of temperature. Such models are analogs to models of growth and decay of disease such as might be present in a pandemic.

Consider an exothermic chemical reaction in which generic species A reacts irreversibly to form generic species B , converting chemical to thermal energy in so doing.



The species A and B are taken to have identical specific heats and identical molecular masses. We characterize the degree of reaction by the so-called *reaction progress variable*, λ . We restrict λ such that

$$\lambda \in [0, 1], \quad (3.367)$$

with $\lambda = 0$, corresponding to all of A being present, and $\lambda = 1$ corresponding to all of B being present. The reaction dynamics can be described by the so-called *law of mass action* with a temperature-dependent Arrhenius kinetic rate, so that

$$\frac{d\lambda}{dt} = a(1 - \lambda) \exp\left(\frac{-\mathcal{E}}{RT}\right), \quad \lambda(0) = 0. \quad (3.368)$$

Here $a > 0$ is a reaction constant with units s^{-1} , and $\mathcal{E} > 0$ is the activation energy, with units kJ/kg . Note

- When T is small, $d\lambda/dt$ is small.
- When the reaction is complete, $\lambda = 1$, we get $d\lambda/dt = 0$.

Now the caloric equation of state for such a mixture must be adjusted to account for exothermic heat release. It can be shown that a rational model for this, in the limit where A and B have the same specific heats c , is

$$\underbrace{u(T, \lambda)}_{\text{internal energy}} = \underbrace{c(T - T_o)}_{\text{thermal energy}} - \underbrace{\lambda q}_{\text{chemical energy}}. \quad (3.369)$$

We have partitioned the internal energy into thermal energy and chemical energy. Here $q > 0$ is the exothermic chemical energy release per unit mass with units kJ/kg . If the system were adiabatic with no work, u must be constant, $u = u_o$, and for such a system, we would get

$$u_o = c(T - T_o) - \lambda q. \quad (3.370)$$

Because we have at the initial state that $T = T_o$ and $\lambda = 0$, we also have $u_o = 0$, thus giving

$$T(\lambda) = T_o + \frac{\lambda q}{c}. \quad (3.371)$$

So at the initial state, before reaction commences, we would have

$$T(\lambda = 0) = T_o. \quad (3.372)$$

At the complete reaction state, we would have

$$T(\lambda = 1) = T_o + \frac{q}{c}. \quad (3.373)$$

Because $q > 0$ and $c > 0$, the temperature at complete reaction increases due to the exothermic nature of the reaction.

Now let us consider the first law for an incompressible system with reaction and convective heat loss to the surroundings. One might consider this a “burning potato” problem, relative to our previous example of a “baking potato.” Start with our previous expression of the first law, Eq. (3.340) and analyze using our new caloric state equation that accounts for reaction:

$$\frac{dU}{dt} = \dot{Q} - \underbrace{\dot{W}}_0, \quad (3.374)$$

$$\frac{d}{dt}(mu) = \dot{Q}, \quad (3.375)$$

$$\frac{d}{dt} \left(m \underbrace{(c(T - T_o) - \lambda q)}_u \right) = \underbrace{-hA(T - T_\infty)}_{\dot{Q}}, \quad (3.376)$$

$$\frac{d}{dt} \left(T - T_o - \frac{q}{c} \lambda \right) = -\frac{hA}{mc} (T - T_\infty), \quad (3.377)$$

$$\frac{dT}{dt} - \frac{q}{c} \frac{d\lambda}{dt} = -\frac{hA}{mc} (T - T_\infty), \quad (3.378)$$

$$\frac{dT}{dt} = -\frac{hA}{mc} (T - T_\infty) + \frac{q}{c} \frac{d\lambda}{dt}. \quad (3.379)$$

Now use Eq. (3.368) to eliminate $d\lambda/dt$ to get

$$\frac{dT}{dt} = - \underbrace{\frac{hA}{mc} (T - T_\infty)}_{\text{effect from heat transfer}} + \underbrace{\frac{q}{c} a(1 - \lambda) \exp\left(\frac{-\mathcal{E}}{RT}\right)}_{\text{increase from exothermic reaction}}. \quad (3.380)$$

As before, we take our mass to be a sphere with radius R and density ρ , giving

$$\frac{hA}{mc} = \frac{3h}{\rho c R}. \quad (3.381)$$

Now both T and λ vary with time t , and the evolution equations are both coupled and non-linear. The mathematical problem is

$$\frac{d\lambda}{dt} = a(1 - \lambda) \exp\left(\frac{-\mathcal{E}}{RT}\right), \quad \lambda(0) = 0, \quad (3.382)$$

$$\frac{dT}{dt} = -\frac{3h}{\rho c R} (T - T_\infty) + \frac{q}{c} a(1 - \lambda) \exp\left(\frac{-\mathcal{E}}{RT}\right), \quad T(0) = T_o. \quad (3.383)$$

There is no exact solution to this coupled system of non-linear ordinary differential equations. In the non-reactive limit, when $a = 0$, we recover our baked potato problem, and there is an exact solution. Let us consider an example identical to our baked potato problem, but allow for the potato to react exothermically. The parameters we use for reaction are not tightly linked to any experiment. While they will induce the correct qualitative behavior, the predictions will not match quantitative experimental results.

Example 3.29

Consider a “burning potato” identical to the “baking potato” of the previous example, but with combustion thermo-kinetic parameters $\mathcal{E} = 1400 \text{ kJ/kg}$, $R = 0.287 \text{ kJ/kg/K}$, $q = 2000 \text{ kJ/kg}$. Explore results for three rates, fast reaction with $a = 10 \text{ s}^{-1}$, moderate reaction with $a = 1 \text{ s}^{-1}$, and slow reaction with $a = 0.1 \text{ s}^{-1}$. Explore analogs with “social distancing” in epidemiology.

Let us first examine the highest possible temperature our system could reach. Let us say it got to T_∞ by convective heat transfer, then burned suddenly so that the temperature rose by q/c . So the maximum possible temperature is

$$T_{max} = T_\infty + \frac{q}{c}, \quad (3.384)$$

$$= (200 \text{ }^\circ\text{C}) + \frac{2000 \frac{\text{kJ}}{\text{kg}}}{4.18 \frac{\text{kJ}}{\text{kg K}}}, \quad (3.385)$$

$$= 678.469 \text{ }^\circ\text{C}. \quad (3.386)$$

We convert all temperatures to an absolute scale in K, as that is what is required by the Arrhenius models of chemical kinetics. Our system is thus

$$\frac{d\lambda}{dt} = a(1 - \lambda) \exp\left(\frac{-1400 \frac{\text{kJ}}{\text{kg}}}{\left(0.287 \frac{\text{kJ}}{\text{kg K}}\right) T}\right), \quad \lambda(0) = 0, \quad (3.387)$$

$$\begin{aligned} \frac{dT}{dt} = & -\frac{3 \left(0.012 \frac{\text{kW}}{\text{m}^2 \text{K}}\right)}{\left(997 \frac{\text{kg}}{\text{m}^3}\right) \left(4.18 \frac{\text{kJ}}{\text{kg K}}\right) (0.05 \text{ m})} (T - 473 \text{ K}), \\ & + \frac{2000 \frac{\text{kJ}}{\text{kg}}}{4.18 \frac{\text{kJ}}{\text{kg K}}} a(1 - \lambda) \exp\left(\frac{-1400 \frac{\text{kJ}}{\text{kg}}}{\left(0.287 \frac{\text{kJ}}{\text{kg K}}\right) T}\right), \quad T(0) = 293 \text{ K}. \end{aligned} \quad (3.388)$$

These two coupled non-linear ordinary differential equations are solved numerically for both values of kinetic rate constant a . Any standard numerical method can handle this, such as the forward Euler method. Here, the routine `NDSOLVE` was used within the `Mathematica` software tool.

We first consider fast reaction with $a = 10 \text{ s}^{-1}$. Plots of T and λ are given in Fig. 3.45. For comparison, the temperature profile of the “baking potato” with $q = 0$ is given as well. We note the following

- The reaction initially is slow, and $\lambda \sim 0$.
- At a time near $t = 4000 \text{ s}$, the reaction accelerates, and λ begins a rapid transition to $\lambda \sim 1$.
- At early time, the temperature of the burning potato is nearly the same as the baking potato. That is because heat transfer dominates reaction at early time.

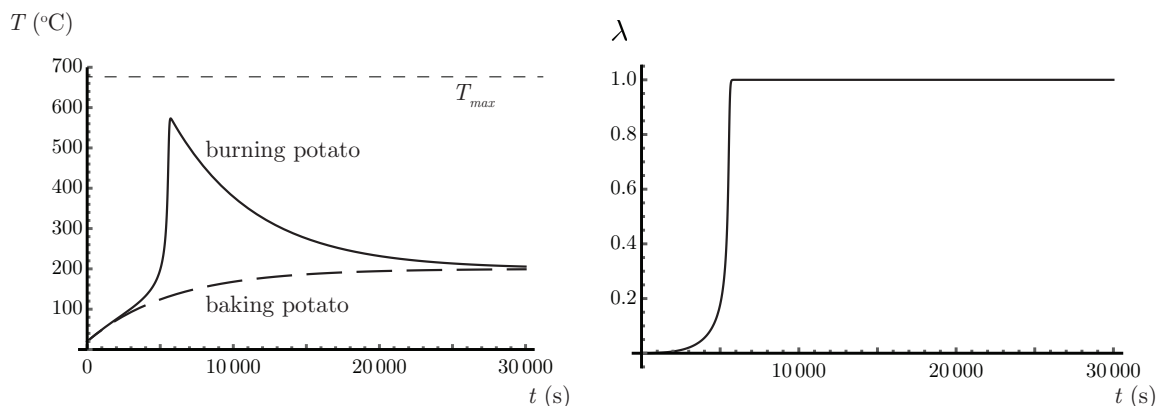

Figure 3.45: Temperature and reaction progress variation with time for a potato model in the presence of heat transfer and reaction with fast reaction kinetics, $a = 10 \text{ s}^{-1}$.

- When the reaction accelerates, the temperature of the burning potato rises sharply relative to the baking potato.
- Convective heat transfer prevents the maximum temperature of $T_{max} = 678.469 \text{ }^\circ\text{C}$ from being realized.
- After the reaction has went to near completion, there is no more chemical energy release, and the burnt potato comes to thermal equilibrium with its surroundings, similar to the baked potato.

We next consider moderate reaction with $a = 1 \text{ s}^{-1}$. Plots of T and λ are given in Fig. 3.46. For

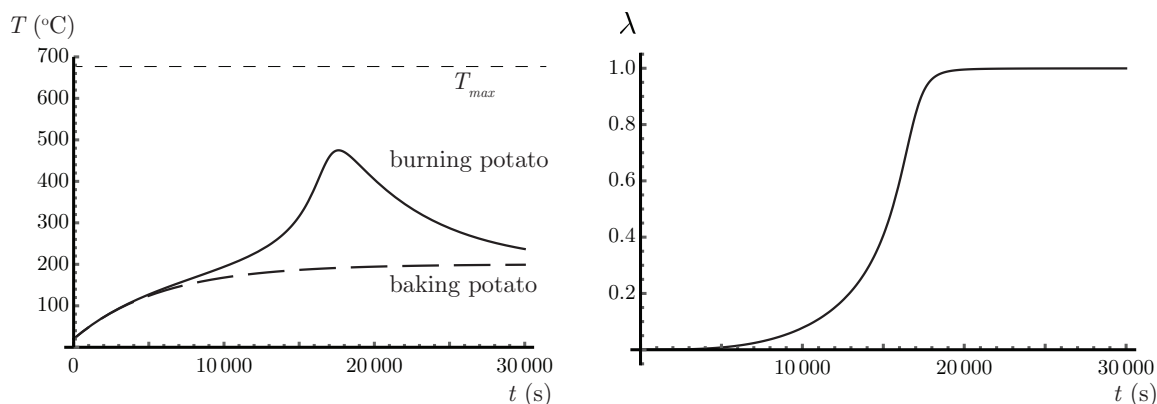

Figure 3.46: Temperature and reaction progress variation with time for a potato model in the presence of heat transfer and reaction with moderate reaction kinetics, $a = 1 \text{ s}^{-1}$.

this moderate rate, the temperature profile of the “baking potato” with $q = 0$ is given as well. We note the following, relative to the fast reaction,

- The reaction remains initially slow, and $\lambda \sim 0$.
- At a later time, near $t = 15000 \text{ s}$, the reaction accelerates, and λ begins a less rapid transition to $\lambda \sim 1$.

- At early time, the temperature of the burning potato is nearly the same as the baking potato. That is because heat transfer dominates reaction at early time.
- When the reaction accelerates, the temperature of the burning potato rises, but not as sharply relative to the baking potato.
- Relative to the fast reaction, the peak temperature is lower, and the time at which the peak is reached is delayed.
- After the reaction has went to near completion, there is no more chemical energy release, and the burnt potato comes to thermal equilibrium with its surroundings, similar to the baked potato.

We last consider slow reaction with $a = 0.1 \text{ s}^{-1}$. Plots of T and λ are given in Fig. 3.47. We note

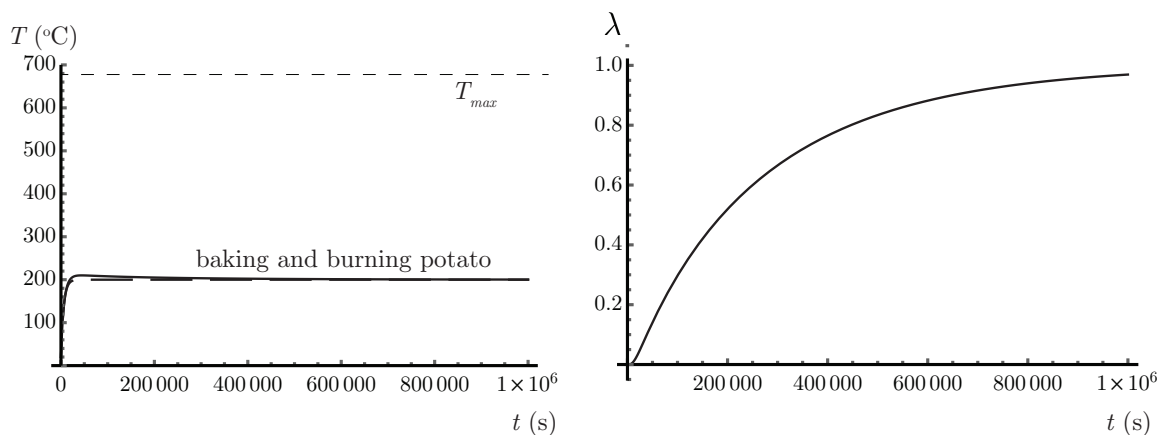

Figure 3.47: Temperature and reaction progress variation with time for a potato model in the presence of heat transfer and reaction with slow reaction kinetics, $a = 0.1 \text{ s}^{-1}$.

the following, relative to the two faster reactions,

- The reaction is much slower, reaching completion near $t = 10^6$ s.
- The burning and baking potatoes have nearly identical temperature profiles. This is because energy released by slow reaction is soon convected away by the faster convection process.
- There is a low peak temperature, relative to the two faster reactions.

While the analogy is not perfect, there is some relevance to epidemiology. One might want to think of T as a measure of the severity of a pandemic, and a as a so-called “social distancing” parameter. Large a corresponds to a tightly packed social network, where rapid transmission can occur. Small a corresponds to a network with more “social distance” between entities. It is possible via reduction of a to effectively mitigate entirely the peak temperature.

3.10 Final comments on conservation

We note the first law is often re-stated as energy is conserved. Let us reconcile this with our mathematical statement, $dE/dt = \dot{Q} - \dot{W}$. This equation tells us that the total energy E can change in response to heat and work crossing the system boundary. But conservation implies that a quantity does not change. We can recover the proper notion of conservation if we speak of an isolated system, that we recall is one that is not influenced by its surroundings. So for an isolated system there can, by definition be no work or heat transfer, so

$$\frac{dE}{dt} = 0, \quad \text{isolated system.} \quad (3.389)$$

Integrating, we find

$$E = \text{constant}, \quad \text{isolated system.} \quad (3.390)$$

Even more fundamentally, we can say, by its definition, that the mass m of a system is constant; thus, the mass of an isolated system must also be constant.

This theoretical formulation is often successful in describing nature for a wide variety of scenarios. However, it does not always succeed. It has been observed to fail for systems that move at a velocity close to the speed of light. For such systems, not only do energy and mass conservation principles fail, so do Newton's laws of mechanics. To realign theory with observation, it was necessary for Einstein, depicted in Fig. 3.48, to re-formulate a new,



Figure 3.48: Albert Einstein (1879-1955), German theoretical physicist who developed theories that explained data better than those of Newton. Image from <http://mathshistory.st-andrews.ac.uk/Biographies/Einstein.html>.

modified set of axioms. In a certain sense the new axioms are simple. For example one can replace Newton's second law with the seemingly simpler $d\mathbf{v}/dt = \mathbf{0}$, where \mathbf{v} is a new

velocity vector; however, the coordinate axes associated with this vector are complicated. Another consequence of Einstein's reformulation was the remarkable results of mass-energy equivalence via the famous relation

$$E = mc^2, \tag{3.391}$$

where c is the speed of light in a vacuum. Another way of viewing Einstein's contributions is via a new conservation property: the mass-energy of an isolated system is constant. It is the conservation of mass-energy that is the key ingredient in both nuclear weapon systems as well as nuclear power generation.

Chapter 4

First law analysis for a control volume

Read BS, Chapter 4

Problems in previous chapters have focused on systems. These systems always were composed of the same matter. However, for a wide variety of engineering devices, for example

- flow in pipes,
- jet engines,
- heat exchangers,
- gas turbines,
- pumps,
- furnaces, or
- air conditioners,

a constant flow of new fluid continuously enters and exits the device. In fact, once the fluid has left the device, we often are not concerned with that fluid, as far as the performance of the device is concerned. Of course, we might care about the pollution emitted by the device and the long term fate of expelled particles. Pollution dispersion, in contrast to pollution-creation, is more a problem of fluid mechanics than thermodynamics.

Analysis of control volumes is slightly more complicated than for systems, and the equations we will ultimately use are slightly more complex. Unfortunately, the underlying mathematics and physics that lead to the development of our simplified control volume equations are highly challenging! Worse still, most beginning thermodynamics texts do not expose the student to all of the many nuances required for the simplification.

We will introduce no new axioms in this chapter. We shall simply formulate our mass and energy conservation axioms for a control volume configuration. A sketch of a generic apparatus for control volume analysis is given in Fig. 4.1.

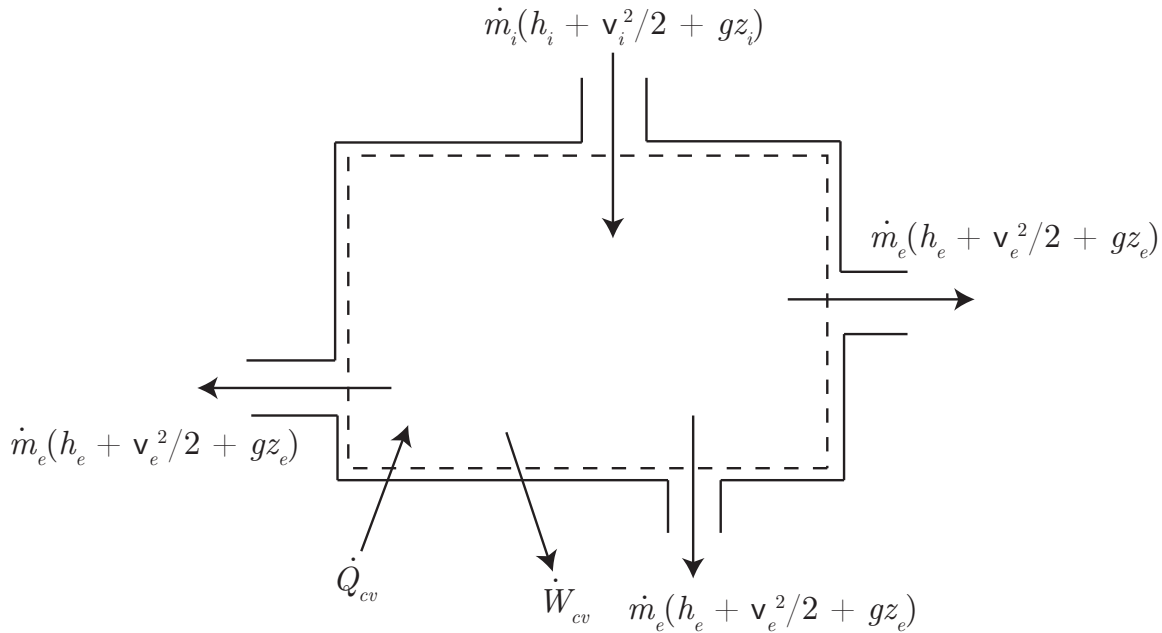

Figure 4.1: Sketch of generic configuration for control volume analysis.

4.1 Detailed derivations of control volume equations

This section will give a summary of the necessary mathematical operations necessary to cast the conservation of mass and energy principles in a traditional control volume formulation. The analysis presented has been amalgamated from a variety of sources. Most directly, it is a specialization of course notes for AME 60635, Intermediate Fluid Mechanics.¹ Basic mathematical foundations are covered well by Kaplan.² A detailed and readable description, that has a stronger emphasis on fluid mechanics, is given in the undergraduate text of Whitaker.³ A rigorous treatment of the development of all equations presented here is included in the graduate text of Aris.⁴ Popular mechanical engineering undergraduate fluids texts have closely related expositions.^{5,6} However, despite their detail, these texts have some minor flaws! The treatment given by BS is not as detailed. This section will use a notation generally consistent with BS and show in detail how to arrive at its results.

¹J. M. Powers, 2019, Lecture Notes on Intermediate Fluid Mechanics, University of Notre Dame, <https://www3.nd.edu/~powers/ame.60635/notes.pdf>.

²W. Kaplan, 2003, *Advanced Calculus*, Fifth Edition, Addison-Wesley, New York.

³S. Whitaker, 1992, *Introduction to Fluid Mechanics*, Krieger, Malabar, Florida.

⁴R. Aris, 1962, *Vectors, Tensors, and the Basic Equations of Fluid Mechanics*, Dover, New York.

⁵F. M. White, 2002, *Fluid Mechanics*, Fifth Edition, McGraw-Hill, New York.

⁶R. W. Fox, A. T. McDonald, and P. J. Pritchard, 2003, *Introduction to Fluid Mechanics*, Sixth Edition, John Wiley, New York.

4.1.1 Relevant mathematics

We will use several theorems that are developed in vector calculus. Here, we give short motivations and presentations. The reader should consult a standard mathematics text for detailed derivations.

4.1.1.1 Fundamental theorem of calculus

Restating here in new variables what was earlier expressed in Eq. (3.31), the fundamental theorem of calculus is as follows

$$\int_{x=a}^{x=b} \psi(x) dx = \int_{x=a}^{x=b} \left(\frac{d\phi}{dx} \right) dx = \phi(b) - \phi(a). \quad (4.1)$$

It effectively says that to find the integral of a function $\psi(x)$, that is the area under the curve, it suffices to find a function ϕ , whose derivative is ψ , i.e. $d\phi/dx = \psi(x)$, evaluate ϕ at each endpoint, and take the difference to find the area under the curve.

4.1.1.2 Divergence theorem

The divergence theorem, often known as Gauss's⁷ theorem, is the analog of the fundamental theorem of calculus extended to volume integrals. Gauss is depicted in Fig. 4.2. While it is



Figure 4.2: Johann Carl Friedrich Gauss (1777-1855), German mathematician; image from <http://mathshistory.st-andrews.ac.uk/Biographies/Gauss.html>.

often attributed to Gauss, who reported it in 1813, it is said that it was first discovered by Joseph Louis Lagrange in 1762.⁸

Let us define the following quantities:

- $t \rightarrow$ time,

⁷Carl Friedrich Gauss, 1777-1855, Brunswick-born German mathematician, considered the founder of modern mathematics. Worked in astronomy, physics, crystallography, optics, bio-statistics, and mechanics. Studied and taught at Göttingen.

⁸https://en.wikipedia.org/wiki/Divergence_theorem.

- $\mathbf{x} \rightarrow$ spatial coordinates,
- $V_a(t) \rightarrow$ arbitrary moving and deforming volume,
- $A_a(t) \rightarrow$ bounding surface of the arbitrary moving volume,
- $\mathbf{n} \rightarrow$ outer unit normal to moving surface, and
- $\phi(\mathbf{x}, t) \rightarrow$ arbitrary vector function of \mathbf{x} and t .

The divergence theorem is as follows:

$$\boxed{\int_{V_a(t)} \nabla \cdot \phi \, dV = \int_{A_a(t)} \phi \cdot \mathbf{n} \, dA.} \quad (4.2)$$

The surface integral is analogous to evaluating the function at the end points in the fundamental theorem of calculus.

If $\phi(\mathbf{x}, t)$ has the form $\phi(\mathbf{x}, t) = \mathbf{c}\phi(\mathbf{x}, t)$, where \mathbf{c} is a *constant* vector and ϕ is a scalar function, then the divergence theorem, Eq. (4.2), reduces to

$$\int_{V_a(t)} \nabla \cdot (\mathbf{c}\phi) \, dV = \int_{A_a(t)} (\mathbf{c}\phi) \cdot \mathbf{n} \, dA, \quad (4.3)$$

$$\int_{V_a(t)} \left(\underbrace{\phi \nabla \cdot \mathbf{c}}_{=0} + \mathbf{c} \cdot \nabla \phi \right) dV = \int_{A_a(t)} \phi (\mathbf{c} \cdot \mathbf{n}) \, dA, \quad (4.4)$$

$$\mathbf{c} \cdot \int_{V_a(t)} \nabla \phi \, dV = \mathbf{c} \cdot \int_{A_a(t)} \phi \mathbf{n} \, dA, \quad (4.5)$$

$$\mathbf{c} \cdot \left(\underbrace{\int_{V_a(t)} \nabla \phi \, dV - \int_{A_a(t)} \phi \mathbf{n} \, dA}_{=0} \right) = 0. \quad (4.6)$$

Now, because \mathbf{c} is arbitrary, the term in parentheses must be zero. Thus,

$$\boxed{\int_{V_a(t)} \nabla \phi \, dV = \int_{A_a(t)} \phi \mathbf{n} \, dA.} \quad (4.7)$$

If we take ϕ to be the scalar of unity (whose gradient must be zero), the divergence theorem reduces to

$$\int_{V_a(t)} \nabla(1) \, dV = \int_{A_a(t)} (1)\mathbf{n} \, dA, \quad (4.8)$$

$$0 = \int_{A_a(t)} (1)\mathbf{n} \, dA, \quad (4.9)$$

$$\int_{A_a(t)} \mathbf{n} \, dA = 0. \quad (4.10)$$

That is, the unit normal to the surface, integrated over the surface, cancels to zero when the entire surface is included.

We will use the divergence theorem (4.2) extensively. It allows us to convert sometimes difficult volume integrals into more easily interpreted surface integrals. It is often useful to use this theorem as a means of toggling back and forth from one form to another.

4.1.1.3 Leibniz's rule

Leibniz's⁹ rule relates time derivatives of integral quantities to a form that distinguishes changes that are happening within the boundaries to changes due to fluxes through boundaries. Leibniz is depicted in Fig. 4.3.



Figure 4.3: Gottfried Wilhelm von Leibniz (1646-1716), German mathematician, philosopher, and polymath who co-invented calculus; image from <http://mathshistory.st-andrews.ac.uk/Biographies/Leibniz.html>.

Let us consider the scenario sketched in Fig. 4.4. Say we have some value of interest, Φ , that results from an integration of a kernel function ϕ over $V_a(t)$, for instance

$$\Phi = \int_{V_a(t)} \phi \, dV. \quad (4.11)$$

We are often interested in the time derivative of Φ , the calculation of which is complicated by the fact that the limits of integration are time-dependent. From the definition of the derivative, we find that

$$\frac{d\Phi}{dt} = \frac{d}{dt} \int_{V_a(t)} \phi \, dV = \lim_{\Delta t \rightarrow 0} \frac{\int_{V_a(t+\Delta t)} \phi(t+\Delta t) \, dV - \int_{V_a(t)} \phi(t) \, dV}{\Delta t}. \quad (4.12)$$

⁹Gottfried Wilhelm von Leibniz, 1646-1716, Leipzig-born German philosopher and mathematician. Invented calculus independent of Newton and employed a superior notation to that of Newton.

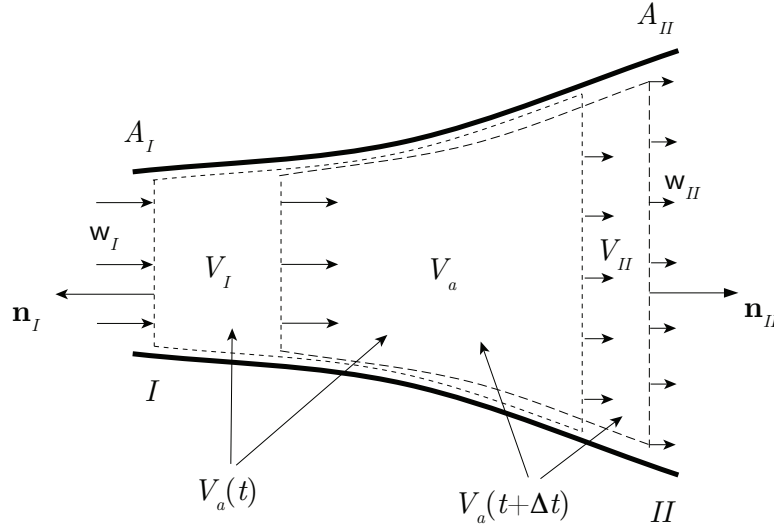

Figure 4.4: Sketch of the motion of an arbitrary volume $V_a(t)$. The boundaries of $V_a(t)$ move with velocity \mathbf{w} . The outer normal to $V_a(t)$ is $A_a(t)$. Here, we focus on just two regions: I , where the volume is abandoning material, and II , where the volume is capturing material.

Now, we have

$$\underbrace{V_a(t + \Delta t)}_{\text{new}} = \underbrace{V_a(t)}_{\text{old}} + \underbrace{V_{II}(\Delta t)}_{\text{captured}} - \underbrace{V_I(\Delta t)}_{\text{abandoned}}. \quad (4.13)$$

Here, $V_{II}(\Delta t)$ is the amount of new volume captured in time increment Δt , and $V_I(\Delta t)$ is the amount of volume abandoned in time increment Δt . So we can split the first integral in the last term of Eq. (4.12) into

$$\underbrace{\int_{V_a(t+\Delta t)} \phi(t + \Delta t) dV}_{\text{new}} = \underbrace{\int_{V_a(t)} \phi(t + \Delta t) dV}_{\text{intrinsically evolved}} + \underbrace{\int_{V_{II}(\Delta t)} \phi(t + \Delta t) dV}_{\text{captured}} - \underbrace{\int_{V_I(\Delta t)} \phi(t + \Delta t) dV}_{\text{abandoned}}, \quad (4.14)$$

that gives us then

$$\frac{d}{dt} \int_{V_a(t)} \phi dV = \lim_{\Delta t \rightarrow 0} \frac{\int_{V_a(t)} \phi(t + \Delta t) dV + \int_{V_{II}(\Delta t)} \phi(t + \Delta t) dV - \int_{V_I(\Delta t)} \phi(t + \Delta t) dV - \int_{V_a(t)} \phi(t) dV}{\Delta t}. \quad (4.15)$$

Rearranging (4.15) by combining terms with common limits of integration, we get

$$\begin{aligned} \frac{d}{dt} \int_{V_a(t)} \phi dV &= \lim_{\Delta t \rightarrow 0} \frac{\int_{V_a(t)} (\phi(t + \Delta t) - \phi(t)) dV}{\Delta t} \\ &+ \lim_{\Delta t \rightarrow 0} \frac{\int_{V_{II}(\Delta t)} \phi(t + \Delta t) dV - \int_{V_I(\Delta t)} \phi(t + \Delta t) dV}{\Delta t}. \end{aligned} \quad (4.16)$$

Let us now further define

- \mathbf{w} \rightarrow the velocity vector of points on the moving surface $V_a(t)$. Here we use the bold notation to indicate \mathbf{w} is a velocity vector, in contrast to the scalar w we would use for velocity magnitude.

Now, the volume swept up by the moving volume in a given time increment Δt is

$$dV_{II} = \underbrace{\mathbf{w} \cdot \mathbf{n}}_{\text{positive}} \Delta t dA_{II} = \underbrace{w_{II} \Delta t}_{\text{distance}} dA_{II}, \quad (4.17)$$

and the volume abandoned is

$$dV_I = \underbrace{\mathbf{w} \cdot \mathbf{n}}_{\text{negative}} \Delta t dA_I = - \underbrace{w_I \Delta t}_{\text{distance}} dA_I. \quad (4.18)$$

Substituting into our definition of the derivative, Eq. (4.16), we get

$$\begin{aligned} \frac{d}{dt} \int_{V_a(t)} \phi dV &= \lim_{\Delta t \rightarrow 0} \int_{V_a(t)} \frac{(\phi(t + \Delta t) - \phi(t))}{\Delta t} dV \\ &+ \lim_{\Delta t \rightarrow 0} \frac{\int_{A_{II}(\Delta t)} \phi(t + \Delta t) w_{II} \Delta t dA_{II} + \int_{A_I(\Delta t)} \phi(t + \Delta t) w_I \Delta t dA_I}{\Delta t}. \end{aligned} \quad (4.19)$$

Now, we note that

- We can use the definition of the partial derivative to simplify the first term on the right side of (4.19),
- The time increment Δt cancels in the surface integrals of (4.19), and
- $A_a(t) = A_I + A_{II}$,

so that

$$\underbrace{\frac{d}{dt} \int_{V_a(t)} \phi dV}_{\text{total time rate of change}} = \underbrace{\int_{V_a(t)} \frac{\partial \phi}{\partial t} dV}_{\text{intrinsic change within volume}} + \underbrace{\int_{A_a(t)} \phi \mathbf{w} \cdot \mathbf{n} dA}_{\text{net capture by moving volume}}. \quad (4.20)$$

This is the three-dimensional scalar version of *Leibniz's rule*. Say we have the special case in which $\phi = 1$; then Leibniz's rule (4.20) reduces to

$$\frac{d}{dt} \int_{V_a(t)} dV = \int_{V_a(t)} \underbrace{\frac{\partial}{\partial t}(1)}_{=0} dV + \int_{A_a(t)} (1) \mathbf{w} \cdot \mathbf{n} dA, \quad (4.21)$$

$$\frac{d}{dt} V_a(t) = \int_{A_a(t)} \mathbf{w} \cdot \mathbf{n} dA. \quad (4.22)$$

This simply says the total volume of the region, that we call $V_a(t)$, changes in response to net motion of the bounding surface.

Example 4.1

Consider a sphere whose initial radius is $r(0) = r_o$ and whose outer boundary is moving outwards, normal to the surface, with a uniform and constant velocity normal to the surface of magnitude w . Find $V(t)$.

The scenario is depicted in Fig. 4.5. Here the volume is no longer arbitrary, as we have specified

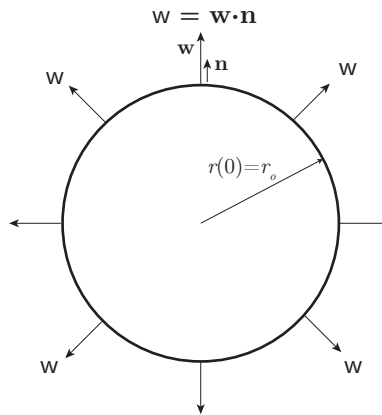

Figure 4.5: Sketch of uniformly expanding sphere.

it, so it is $V(t)$. And the bounding surface is $A(t)$. The velocity of the outer boundary is uniform and aligned with the outer surface normal \mathbf{n} ,

$$\mathbf{w} = w\mathbf{n}. \quad (4.23)$$

Thus,

$$\mathbf{w} \cdot \mathbf{n} = w \underbrace{\mathbf{n} \cdot \mathbf{n}}_{=1} = +w. \quad (4.24)$$

Thus Eq. (4.22) reduces to

$$\frac{dV}{dt} = \int_{A(t)} \mathbf{w} \, dA, \quad (4.25)$$

$$= \mathbf{w} \int_{A(t)} dA, \quad (4.26)$$

$$= \mathbf{w}A(t). \quad (4.27)$$

For the sphere, we have $V = 4\pi r^3/3$ and $A = 4\pi r^2$, so we get

$$\frac{d}{dt} \left(\frac{4}{3}\pi r^3 \right) = \mathbf{w}4\pi r^2, \quad (4.28)$$

$$\frac{1}{3} \frac{d}{dt} r^3 = \mathbf{w}r^2, \quad (4.29)$$

$$r^2 \frac{dr}{dt} = \mathbf{w}r^2, \quad (4.30)$$

$$\frac{dr}{dt} = \mathbf{w}. \quad (4.31)$$

This is not a surprise and likely could be inferred by simple intuition. So integrating and applying the initial condition $r(0) = r_o$, we get

$$r(t) = \mathbf{w}t + r_o. \quad (4.32)$$

Thus,

$$\boxed{V(t) = \frac{4}{3}\pi (\mathbf{w}t + r_o)^3}. \quad (4.33)$$

Leibniz's rule (4.20) reduces to a more familiar result in the one-dimensional limit. We can then say

$$\frac{d}{dt} \int_{x=a(t)}^{x=b(t)} \phi(x, t) \, dx = \int_{x=a(t)}^{x=b(t)} \frac{\partial \phi}{\partial t} \, dx + \frac{db}{dt} \phi(b(t), t) - \frac{da}{dt} \phi(a(t), t). \quad (4.34)$$

As in the fundamental theorem of calculus, Eq. (4.1), for the one-dimensional case, we do not have to evaluate a surface integral; instead, we simply must consider the function at its endpoints. Here, db/dt and da/dt are the velocities of the bounding surface and are equivalent to \mathbf{w} . The terms $\phi(b(t), t)$ and $\phi(a(t), t)$ are equivalent to evaluating ϕ on $A_a(t)$.

We can also apply the divergence theorem, Eq. (4.2), to Leibniz's rule, Eq. (4.20), to convert the surface integral into a volume integral to get

$$\frac{d}{dt} \int_{V_a(t)} \phi \, dV = \int_{V_a(t)} \frac{\partial \phi}{\partial t} \, dV + \int_{V_a(t)} \nabla \cdot (\phi \mathbf{w}) \, dV. \quad (4.35)$$

Combining the two volume integrals, we get

$$\frac{d}{dt} \int_{V_a(t)} \phi \, dV = \int_{V_a(t)} \left(\frac{\partial \phi}{\partial t} + \nabla \cdot (\phi \mathbf{w}) \right) \, dV. \quad (4.36)$$

4.1.1.4 General transport theorem

Let B be an arbitrary extensive thermodynamic property, and β be the corresponding intensive thermodynamic property so that

$$dB = \beta dm. \quad (4.37)$$

The product of a differential amount of mass dm with the intensive property β gives a differential amount of the extensive property. Because

$$dm = \rho dV, \quad (4.38)$$

where ρ is the mass density and dV is a differential amount of volume, we have

$$dB = \beta\rho dV. \quad (4.39)$$

If we take the arbitrary $\phi = \rho\beta$, Leibniz's rule, Eq. (4.20), becomes our *general transport theorem*:

$$\boxed{\frac{d}{dt} \int_{V_a(t)} \rho\beta dV = \int_{V_a(t)} \frac{\partial}{\partial t}(\rho\beta) dV + \int_{A_a(t)} \rho\beta (\mathbf{w} \cdot \mathbf{n}) dA.} \quad (4.40)$$

Applying the divergence theorem, Eq. (4.2), to the general transport theorem, Eq. (4.40), we find the alternate form

$$\boxed{\frac{d}{dt} \int_{V_a(t)} \rho\beta dV = \int_{V_a(t)} \left(\frac{\partial}{\partial t}(\rho\beta) + \nabla \cdot (\rho\beta\mathbf{w}) \right) dV.} \quad (4.41)$$

4.1.1.5 Reynolds transport theorem

Osborne Reynolds¹⁰ made many pioneering contributions to fluid mechanics. He is depicted in Fig. 4.6. Among other things, he wrote a treatise on the development of conservation principles in a general sense.¹¹ From this work, and after employing more modern notation, we arrive at what is now known as the *Reynolds transport theorem* if we force the arbitrary velocity of the moving volume to take on the velocity of a fluid particle, i.e. take

$$\mathbf{w} = \mathbf{v}. \quad (4.42)$$

Here \mathbf{v} is the velocity vector of the fluid particle, in contrast to the scalar velocity magnitude v . In this case, our arbitrary volume is no longer arbitrary. Instead, it always contains the same fluid particles. We call this volume a

¹⁰Osborne Reynolds, 1842-1912, Belfast-born British engineer and physicist, educated in mathematics at Cambridge, first professor of engineering at Owens College, Manchester, did fundamental experimental work in fluid mechanics and heat transfer.

¹¹O. Reynolds, 1903, *Papers on Mechanical and Physical Subjects, Volume III, The Sub-Mechanics of the Universe*, Cambridge, Cambridge.



Figure 4.6: Osborne Reynolds (1842-1912), Anglo-Irish engineer; image from <http://mathshistory.st-andrews.ac.uk/Biographies/Reynolds.html>.

- MATERIAL VOLUME, $V_m(t)$: a volume that always contains the same fluid particles.

Corresponding to this we also have a

- MATERIAL SURFACE, $A_m(t)$: a closed surface that always encloses the same fluid particles.

The proper way to generalize laws of nature that were developed for point masses is to consider collections of fixed point masses, that will always reside within a material volume. That said, it is simple to specialize the general transport theorem to obtain the Reynolds transport theorem. Here, we give two versions, the first using volume and surface integrals, and the second using volume integrals only. In this special case, Eqs. (4.40) and (4.41) become, respectively,

$$\frac{d}{dt} \int_{V_m(t)} \rho\beta \, dV = \int_{V_m(t)} \frac{\partial}{\partial t}(\rho\beta) \, dV + \int_{A_m(t)} \rho\beta (\mathbf{v} \cdot \mathbf{n}) \, dA, \quad (4.43)$$

$$\frac{d}{dt} \int_{V_m(t)} \rho\beta \, dV = \int_{V_m(t)} \left(\frac{\partial}{\partial t}(\rho\beta) + \nabla \cdot (\rho\beta\mathbf{v}) \right) \, dV. \quad (4.44)$$

The implications of Eq. (4.43) are summarized in the words of Reynolds in Fig. 4.6.

4.1.1.6 Fixed (control) volumes

If we take our arbitrary volume to be fixed in space, it is most often known as a

- CONTROL VOLUME: a fixed volume in space.

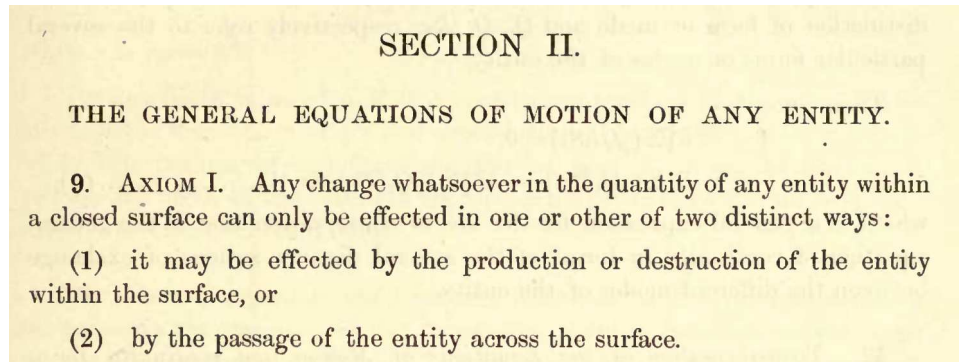

Figure 4.7: Image from Reynolds' 1903 study, p. 9, giving his key general axiom.

For control volumes

$$\mathbf{w} = \mathbf{0}. \quad (4.45)$$

Thus, the arbitrary volume loses its time-dependency, so that

$$V_a(t) = V, \quad A_a(t) = A, \quad (4.46)$$

and the general transport theorem, Eq. (4.40), reduces to

$$\boxed{\frac{d}{dt} \int_V \rho\beta \, dV = \int_V \frac{\partial}{\partial t} (\rho\beta) \, dV.} \quad (4.47)$$

4.1.2 Conservation axioms

A fundamental goal of mechanics is to convert the verbal notions that embody the basic axioms into usable mathematical expressions. First, we must list those axioms. The axioms themselves are simply principles that have been observed to have wide validity as long as length scales are sufficiently large to contain many molecules. Many of these axioms can be applied to molecules as well. The axioms cannot be proven. They are simply statements that have been useful in describing the universe.

A summary of the axioms in words is as follows

- *Mass conservation principle:* The time rate of change of mass of a material region is zero.
- *Linear momenta principle:* The time rate of change of the linear momenta of a material region is equal to the sum of forces acting on the region. This is Euler's generalization of Newton's second law of motion.
- *Angular momenta principle:* The time rate of change of the angular momenta of a material region is equal to the sum of the torques acting on the region. This was first formulated by Euler.

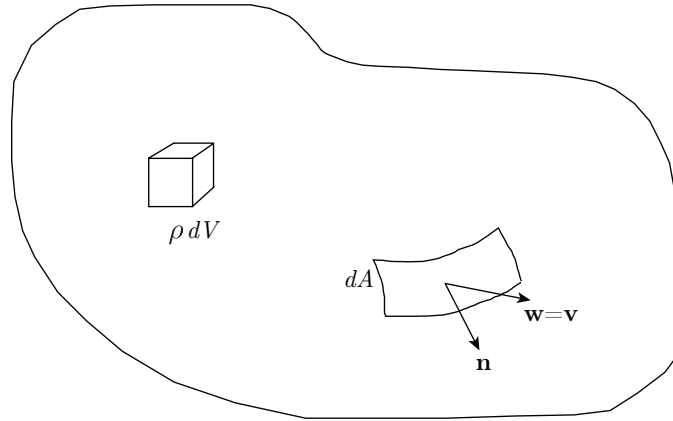

Figure 4.8: Sketch of finite material region $V_m(t)$, infinitesimal mass element ρdV , and infinitesimal surface element dA with unit normal \mathbf{n} , and general velocity \mathbf{w} equal to fluid velocity \mathbf{v} .

- *Energy conservation principle:* The time rate of change of energy within a material region is equal to the rate that energy is received by heat and work interactions. This is the first law of thermodynamics.
- *Entropy inequality:* The time rate of change of entropy within a material region is greater than or equal to the ratio of the rate of heat transferred to the region and the absolute temperature of the region. This is the second law of thermodynamics.

Here, we shall systematically convert two of these axioms, the mass conservation principle and the energy conservation principle, into mathematical form.

4.1.2.1 Mass

Mass is an extensive property for which we have

$$B = m, \quad \beta = 1. \quad (4.48)$$

The mass conservation axiom is simple to state mathematically. It is

$$\frac{d}{dt}m = 0. \quad (4.49)$$

A relevant material volume is sketched in Fig. 4.8. We can define the mass enclosed within a material volume based upon the local value of density:

$$m = \int_{V_m(t)} \rho dV. \quad (4.50)$$

So the mass conservation axiom is

$$\frac{d}{dt} \int_{V_m(t)} \rho dV = 0. \quad (4.51)$$

Invoking the Reynolds transport theorem (4.43), $\frac{d}{dt} \int_{V_m(t)} [] dV = \int_{V_m(t)} \frac{\partial}{\partial t} [] dV + \int_{A_m(t)} \mathbf{v} \cdot \mathbf{n} [] dA$, we get

$$\frac{d}{dt} \int_{V_m(t)} \rho dV = \int_{V_m(t)} \frac{\partial \rho}{\partial t} dV + \int_{A_m(t)} \rho \mathbf{v} \cdot \mathbf{n} dA = 0. \quad (4.52)$$

The first equality of Eq. (4.52) is simply a mathematical statement involving definitions; forcing either of the terms to equal zero is a statement of physics. Now, we invoke the divergence theorem, Eq. (4.2) $\int_{V(t)} \nabla \cdot [] dV = \int_{A(t)} \mathbf{n} \cdot [] dA$, to convert a surface integral to a volume integral to get the mass conservation axiom to read as

$$\int_{V_m(t)} \frac{\partial \rho}{\partial t} dV + \int_{V_m(t)} \nabla \cdot (\rho \mathbf{v}) dV = 0, \quad (4.53)$$

$$\int_{V_m(t)} \underbrace{\left(\frac{\partial \rho}{\partial t} + \nabla \cdot (\rho \mathbf{v}) \right)}_{=0} dV = 0. \quad (4.54)$$

Now, in an important step, we realize that the only way for this integral, that has absolutely arbitrary limits of integration, to always be zero, is for the integrand itself to always be zero. Hence, we have

$$\boxed{\frac{\partial \rho}{\partial t} + \nabla \cdot (\rho \mathbf{v}) = 0.} \quad (4.55)$$

This is the important differential form of the mass conservation principle. We can expand this via the product rule to also say

$$\underbrace{\frac{\partial \rho}{\partial t} + \mathbf{v} \cdot \nabla \rho}_{=d\rho/dt} + \rho \nabla \cdot \mathbf{v} = 0. \quad (4.56)$$

It can be shown that if we travel at the same velocity of a fluid particle, that any changes with time are properly described by the so-called *material derivative*:

$$\frac{d}{dt} \equiv \frac{\partial}{\partial t} + \mathbf{v} \cdot \nabla. \quad (4.57)$$

So the mass conservation axiom, Eq. (4.56), can be recast as

$$\frac{d\rho}{dt} + \rho \nabla \cdot \mathbf{v} = 0, \quad (4.58)$$

so long as d/dt is interpreted as the derivative following a particle: the material derivative. Rearranging, we see

$$\frac{d\rho}{dt} = -\rho \nabla \cdot \mathbf{v}, \quad (4.59)$$

telling us that a fluid particle's density changes in response to the divergence of its velocity vector field. Moreover, a fluid particle that is *incompressible* must be associated with a divergence-free velocity field, $\nabla \cdot \mathbf{v} = 0$.

Example 4.2

For a fluid in the velocity vector field

$$\mathbf{v} = \begin{pmatrix} v_x \\ 0 \\ 0 \end{pmatrix} = \begin{pmatrix} v_o \frac{x}{L} \\ 0 \\ 0 \end{pmatrix}, \quad (4.60)$$

find the time rate of change of its density as well as its acceleration.

For this one-dimensional flow that only varies in the x direction, we have

$$\nabla \cdot \mathbf{v} = \frac{\partial v_x}{\partial x} + \frac{\partial v_y}{\partial y} + \frac{\partial v_z}{\partial z} = \frac{\partial}{\partial x} \left(v_o \frac{x}{L} \right) + 0 + 0 = \frac{v_o}{L}. \quad (4.61)$$

So we have from mass conservation that

$$\frac{d\rho}{dt} = -\rho \nabla \cdot \mathbf{v}. \quad (4.62)$$

This gives

$$\boxed{\frac{d\rho}{dt} = -\frac{\rho v_o}{L}}. \quad (4.63)$$

For $\rho, v_o, L > 0$, this flow has density decreasing with time of a fluid particle. That is because the boundaries of the material region are being stretched by the velocity field.

The acceleration of the fluid particle is

$$\frac{d\mathbf{v}}{dt} = \frac{\partial \mathbf{v}}{\partial t} + \mathbf{v} \cdot \nabla \mathbf{v}. \quad (4.64)$$

Because we have strictly one-dimensional motion, this reduces to

$$\frac{dv_x}{dt} = \frac{\partial v_x}{\partial t} + v_x \frac{\partial v_x}{\partial x}, \quad (4.65)$$

$$= 0 + \left(v_o \frac{x}{L} \right) \left(v_o \frac{1}{L} \right). \quad (4.66)$$

This gives

$$\boxed{\frac{dv_x}{dt} = \frac{v_o^2 x}{L^2}}. \quad (4.67)$$

The fluid particle is accelerating to the right. Even though the velocity field does not change with time, the position and velocity of an individual fluid particle does change as it travels. The configuration is sketched in Fig. 4.9.

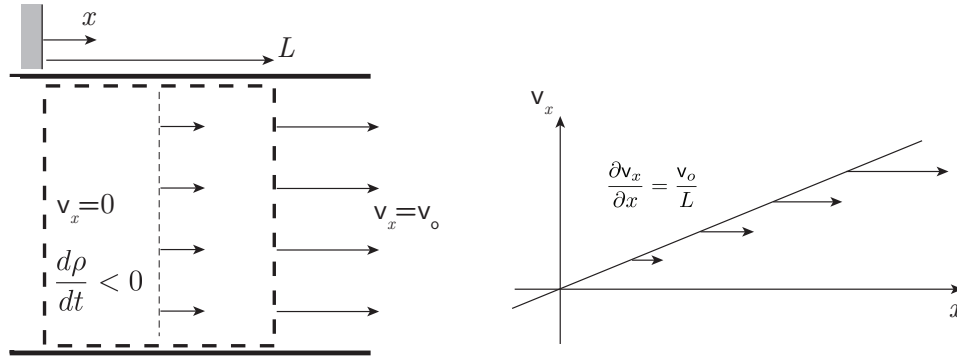

Figure 4.9: Sketch of a fluid element in a velocity field with non-zero divergence. The fluid is stationary at $x = 0$ and has velocity \mathbf{v}_o when $x = L$. This stretches the material volume, causing the density of the material volume to drop. And the fluid particle accelerates as its x -coordinate increases. Also sketched is the velocity as a function of x ; the slope of this curve is the velocity gradient, which here is constant.

Example 4.3

Show by considering $\rho = \rho(t, x, y, z)$ that the material derivative $d\rho/dt = \partial\rho/\partial t + \mathbf{v} \cdot \nabla\rho$.

If $\rho = \rho(t, x, y, z)$, then by the definition of a total differential of a function of many variables, see Eq. (3.3),

$$d\rho = \frac{\partial\rho}{\partial t} dt + \frac{\partial\rho}{\partial x} dx + \frac{\partial\rho}{\partial y} dy + \frac{\partial\rho}{\partial z} dz. \quad (4.68)$$

Let us divide by a time differential dt to get then

$$\frac{d\rho}{dt} = \frac{\partial\rho}{\partial t} + \frac{\partial\rho}{\partial x} \frac{dx}{dt} + \frac{\partial\rho}{\partial y} \frac{dy}{dt} + \frac{\partial\rho}{\partial z} \frac{dz}{dt}. \quad (4.69)$$

Now with

$$\frac{dx}{dt} = v_x, \quad \frac{dy}{dt} = v_y, \quad \frac{dz}{dt} = v_z, \quad (4.70)$$

we get after small rearrangement

$$\frac{d\rho}{dt} = \frac{\partial\rho}{\partial t} + v_x \frac{\partial\rho}{\partial x} + v_y \frac{\partial\rho}{\partial y} + v_z \frac{\partial\rho}{\partial z}, \quad (4.71)$$

$$= \frac{\partial\rho}{\partial t} + \underbrace{(v_x \quad v_y \quad v_z)}_{\mathbf{v}} \underbrace{\begin{pmatrix} \frac{\partial\rho}{\partial x} \\ \frac{\partial\rho}{\partial y} \\ \frac{\partial\rho}{\partial z} \end{pmatrix}}_{\nabla\rho}, \quad (4.72)$$

$$= \frac{\partial\rho}{\partial t} + \mathbf{v} \cdot \nabla\rho. \quad (4.73)$$

It is a material derivative because we are insisting that $dx/dt = v_x$, $dy/dt = v_y$, $dz/dt = v_z$, the material particle velocity.

Example 4.4

Prove for a general intensive thermodynamic property β that

$$\frac{d}{dt} \int_{V_m(t)} \rho \beta \, dV = \int_{V_m(t)} \rho \frac{d\beta}{dt} \, dV. \quad (4.74)$$

We have from the Reynolds transport theorem, Eq. (4.43), that

$$\frac{d}{dt} \int_{V_m(t)} \rho \beta \, dV = \int_{V_m(t)} \frac{\partial}{\partial t} (\rho \beta) \, dV + \int_{A_m(t)} \rho \beta (\mathbf{v} \cdot \mathbf{n}) \, dA, \quad (4.75)$$

$$= \int_{V_m(t)} \left(\frac{\partial}{\partial t} (\rho \beta) + \nabla \cdot (\rho \beta \mathbf{v}) \right) \, dV, \quad (4.76)$$

$$= \int_{V_m(t)} \left(\beta \left(\underbrace{\frac{\partial \rho}{\partial t} + \nabla \cdot (\rho \mathbf{v})}_{=0} \right) + \rho \left(\underbrace{\frac{\partial \beta}{\partial t} + \mathbf{v} \cdot \nabla \beta}_{=d\beta/dt} \right) \right) \, dV, \quad (4.77)$$

$$= \int_{V_m(t)} \rho \frac{d\beta}{dt} \, dV. \quad (4.78)$$

We can get a useful *control volume* formulation by integrating the mass conservation principle (4.55) over a *fixed* volume V :

$$\int_V \left(\frac{\partial \rho}{\partial t} + \nabla \cdot (\rho \mathbf{v}) \right) \, dV = \underbrace{\int_V 0 \, dV}_{=0}. \quad (4.79)$$

Now, the integral of 0 over a fixed domain must be zero. This is equivalent to saying $\int_a^b 0 \, dx = 0$, where the area under the curve of 0 has to be zero. So we have

$$\int_V \left(\frac{\partial \rho}{\partial t} + \nabla \cdot (\rho \mathbf{v}) \right) \, dV = 0. \quad (4.80)$$

Next apply the divergence theorem (4.2) to (4.80) to get

$$\int_V \frac{\partial \rho}{\partial t} \, dV + \int_A \rho \mathbf{v} \cdot \mathbf{n} \, dA = 0. \quad (4.81)$$

Applying now the result from (4.47) to (4.81), we see for the fixed volume that

$$\frac{d}{dt} \int_V \rho \, dV + \int_A \rho \mathbf{v} \cdot \mathbf{n} \, dA = 0. \quad (4.82)$$

We note now that at an inlet that \mathbf{v} points in an opposite direction to \mathbf{n} , so we have

$$\mathbf{v} \cdot \mathbf{n} < 0, \quad \text{at inlets.} \quad (4.83)$$

At exits, \mathbf{v} and \mathbf{n} point in the same direction so that

$$\mathbf{v} \cdot \mathbf{n} > 0, \quad \text{at exits.} \quad (4.84)$$

If now, we take the simplifying assumption that ρ and \mathbf{v} have no spatial variation across inlets and exits, we get for a control volume with one inlet and one exit that

$$\frac{d}{dt} \int_V \rho dV + \rho_e |\mathbf{v}_e| A_e - \rho_i |\mathbf{v}_i| A_i = 0. \quad (4.85)$$

Here, the subscript i denotes inlet, and the subscript e denotes exit. Rearranging (4.85), we find

$$\frac{d}{dt} \int_V \rho dV = \rho_i |\mathbf{v}_i| A_i - \rho_e |\mathbf{v}_e| A_e. \quad (4.86)$$

We now define the mass in the control volume m_{cv} as

$$\boxed{m_{cv} = \int_V \rho dV.} \quad (4.87)$$

Here, (4.87) is equivalent to the equation on p. 144 of BS. Thus, we have

$$\underbrace{\frac{dm_{cv}}{dt}}_{\text{rate of change of mass}} = \underbrace{\rho_i |\mathbf{v}_i| A_i}_{\text{mass rate in}} - \underbrace{\rho_e |\mathbf{v}_e| A_e}_{\text{mass rate out}}. \quad (4.88)$$

Here, m_{cv} is the mass enclosed in the control volume. If there is no net rate of change of mass the control volume is in *steady state*, and we can say that the mass flow in must equal the mass flow out:

$$\rho_i |\mathbf{v}_i| A_i = \rho_e |\mathbf{v}_e| A_e. \quad (4.89)$$

We define the *mass flow rate* \dot{m} as

$$\dot{m} = \rho |\mathbf{v}| A. \quad (4.90)$$

For steady flows with a single entrance and exit, we have

$$\dot{m} = \text{constant.} \quad (4.91)$$

For unsteady flows with a single entrance and exit, we can rewrite (4.88) as

$$\frac{dm_{cv}}{dt} = \dot{m}_i - \dot{m}_e. \quad (4.92)$$

For unsteady flow with many entrances and exits, we can generalize (4.88) as

$$\underbrace{\frac{dm_{cv}}{dt}}_{\text{rate of change of mass}} = \underbrace{\sum \rho_i |\mathbf{v}_i| A_i}_{\text{mass rate in}} - \underbrace{\sum \rho_e |\mathbf{v}_e| A_e}_{\text{mass rate out}}, \quad (4.93)$$

$$\boxed{\underbrace{\frac{dm_{cv}}{dt}}_{\text{rate of change of mass}} = \underbrace{\sum \dot{m}_i}_{\text{mass rate in}} - \underbrace{\sum \dot{m}_e}_{\text{mass rate out}}.} \quad (4.94)$$

Note that (4.94) is fully equivalent to BS's Eq. (4.1) (p. 143), but that it actually takes a good deal of effort to get to this point with rigor! For steady state conditions with many entrances and exits we can say

$$\sum \rho_i |\mathbf{v}_i| A_i = \sum \rho_e |\mathbf{v}_e| A_e. \quad (4.95)$$

Thus

$$\boxed{\sum \dot{m}_i = \sum \dot{m}_e.} \quad (4.96)$$

Here, (4.96) is the same as BS's (4.9), p. 149.

Example 4.5

Consider a control volume with three openings. A sketch is given in Fig. 4.10. The system is in a steady state, and water is the working fluid. Measurements at the openings shows conditions at each to be

1. inlet with $T_1 = 200$ °C, $P_1 = 7$ bar, $\dot{m}_1 = 40$ kg/s
2. inlet with $A_2 = 25$ cm², $T_2 = 40$ °C, $P_2 = 7$ bar.
3. exit with $x_3 = 0$, $P_3 = 7$ bar, $(Av)_3 = 0.06$ m³/s.

Find \dot{m}_3 , \dot{m}_2 and v_2 .

Our mass conservation equation is

$$\frac{dm_{cv}}{dt} = \sum \dot{m}_i - \sum \dot{m}_e, \quad (4.97)$$

$$= \dot{m}_1 + \dot{m}_2 - \dot{m}_3. \quad (4.98)$$

Now, because the problem is steady, $d/dt = 0$. Thus, there is no net accumulation of mass in the control volume, and we must have

$$0 = \dot{m}_1 + \dot{m}_2 - \dot{m}_3, \quad (4.99)$$

$$\dot{m}_2 = \dot{m}_3 - \dot{m}_1. \quad (4.100)$$

Now, $\dot{m} = \rho v A = Av/v$. So

$$\dot{m}_3 = \frac{(Av)_3}{v_3}. \quad (4.101)$$

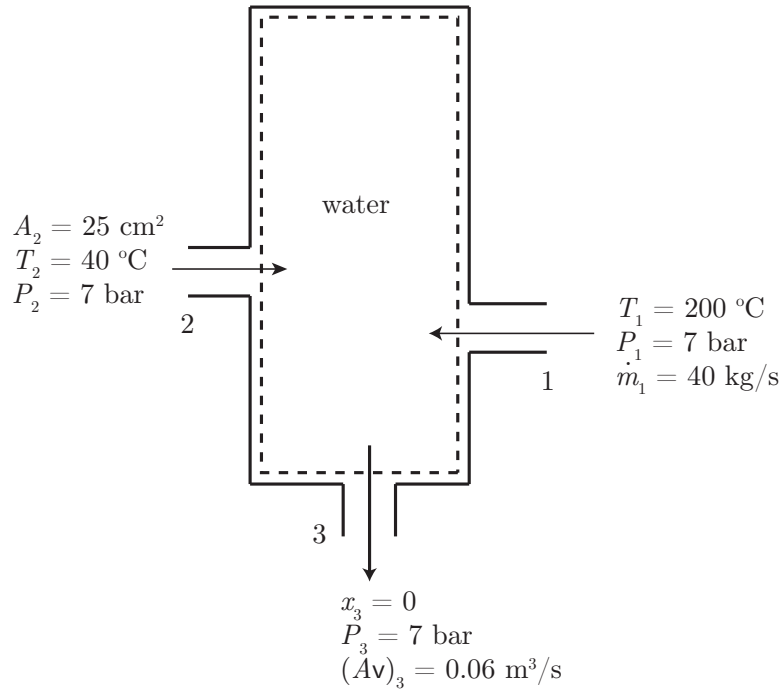

Figure 4.10: Sketch for steady state control volume mass conservation example.

Now, we have two properties at state 3, so we know the state. The water tables thus give us

$$v_3 = v_f = 0.001108 \frac{\text{m}^3}{\text{kg}}. \quad (4.102)$$

so

$$\dot{m}_3 = \frac{0.06 \frac{\text{m}^3}{\text{s}}}{0.001108 \frac{\text{m}^3}{\text{kg}}} = \boxed{54.1516 \frac{\text{kg}}{\text{s}}}. \quad (4.103)$$

So

$$\dot{m}_2 = \dot{m}_3 - \dot{m}_1 = \left(54.1516 \frac{\text{kg}}{\text{s}} \right) - \left(40 \frac{\text{kg}}{\text{s}} \right) = \boxed{14.1516 \frac{\text{kg}}{\text{s}}}. \quad (4.104)$$

Now,

$$\dot{m}_2 = \frac{A_2 v_2}{v_2}, \quad (4.105)$$

$$v_2 = \frac{\dot{m}_2 v_2}{A_2}. \quad (4.106)$$

Now, state 2 is a compressed liquid. Let us estimate v_2 by v_f at $T_2 = 40 \text{ }^\circ\text{C}$. We find this is $v_2 = 0.001008 \text{ m}^3/\text{kg}$. So

$$v_2 = \frac{\left(14.1516 \frac{\text{kg}}{\text{s}} \right) \left(0.001008 \frac{\text{m}^3}{\text{kg}} \right)}{(25 \text{ cm}^2) \left(\frac{1 \text{ m}}{100 \text{ cm}} \right)^2}, \quad (4.107)$$

$$= \boxed{5.70594 \frac{\text{m}}{\text{s}}}. \quad (4.108)$$

Example 4.6

A tank is initially empty. A liquid with $\rho = 62.4 \text{ lbm/ft}^3$ is poured into the tank at a constant mass flow rate of $\dot{m}_i = 7 \text{ lbm/s}$. The tank has cross-sectional area $A = 0.2 \text{ ft}^2$, and the fluid in the tank has a variable height $H(t)$. There is a hole at the bottom of the tank. The fluid flows out of the tank at a rate proportional to the fluid height: $\dot{m}_e = kH$, where $k = 1.4 \text{ lbm/ft/s}$. Find $H(t)$. A sketch is given in Fig. 4.11.

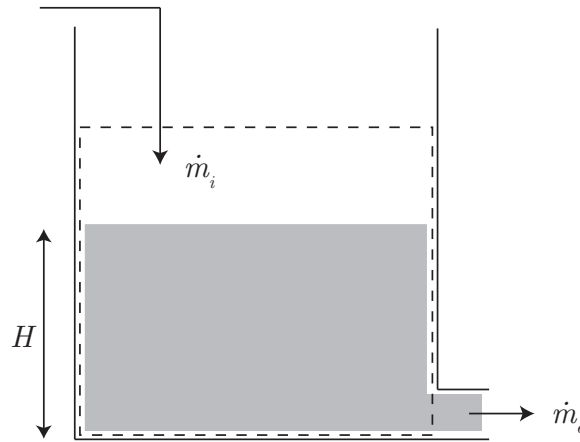

Figure 4.11: Sketch of tank filling problem.

Our mass conservation law for the control volume says

$$\frac{dm_{cv}}{dt} = \dot{m}_i - \dot{m}_e. \quad (4.109)$$

Now, $m_{cv} = \rho V = \rho AH(t)$. Substituting, we get

$$\frac{d}{dt}(\rho AH) = \dot{m}_i - kH, \quad (4.110)$$

$$\rho A \frac{dH}{dt} = \dot{m}_i - kH, \quad (4.111)$$

$$\frac{dH}{dt} = \frac{\dot{m}_i}{\rho A} - \frac{k}{\rho A} H, \quad (4.112)$$

$$\frac{dH}{dt} = \frac{\dot{m}_i}{\rho A} \left(1 - \frac{k}{\dot{m}_i} H \right). \quad (4.113)$$

The only variable here is $H(t)$. Every other parameter is a known constant. We can separate variables

to get

$$\frac{dH}{1 - \frac{k}{\dot{m}_i}H} = \frac{\dot{m}_i}{\rho A} dt, \quad (4.114)$$

$$\int \frac{dH}{1 - \frac{k}{\dot{m}_i}H} = \int \frac{\dot{m}_i}{\rho A} dt, \quad (4.115)$$

$$-\frac{\dot{m}_i}{k} \ln \left(1 - \frac{k}{\dot{m}_i}H \right) = \frac{\dot{m}_i}{\rho A} t + C. \quad (4.116)$$

Now, when $t = 0$, we have $H = 0$, so $C = 0$ and

$$-\frac{\dot{m}_i}{k} \ln \left(1 - \frac{k}{\dot{m}_i}H \right) = \frac{\dot{m}_i}{\rho A} t, \quad (4.117)$$

$$\ln \left(1 - \frac{k}{\dot{m}_i}H \right) = -\frac{k}{\rho A} t, \quad (4.118)$$

$$1 - \frac{k}{\dot{m}_i}H = \exp \left(-\frac{k}{\rho A} t \right), \quad (4.119)$$

$$H = \frac{\dot{m}_i}{k} \left(1 - \exp \left(-\frac{k}{\rho A} t \right) \right). \quad (4.120)$$

Note

$$\lim_{t \rightarrow \infty} H(t) = \frac{\dot{m}_i}{k}. \quad (4.121)$$

In the long time limit, a steady state height is reached where the flow out balances the flow in. If we increase \dot{m}_i , the steady state height increases proportionally.

We also see by inspection that the time constant is

$$\tau = \frac{\rho A}{k}. \quad (4.122)$$

This gives an estimate of how long it takes to reach the steady state height.

Substituting numbers, we find

$$H(t) = \left(\frac{7 \frac{\text{lbm}}{\text{s}}}{1.4 \frac{\text{lbm}}{\text{ft s}}} \right) \left(1 - \exp \left(-\frac{1.4 \frac{\text{lbm}}{\text{ft s}}}{(62.4 \frac{\text{lbm}}{\text{ft}^3}) (0.2 \text{ ft}^2)} t \right) \right), \quad (4.123)$$

$$= (5 \text{ ft}) \left(1 - \exp \left(-\frac{t}{8.91429 \text{ s}} \right) \right). \quad (4.124)$$

The time constant is $\tau = 8.91429 \text{ s}$; $H(\infty)$ is 5 ft. A plot of $H(t)$ is shown in Fig. 4.12. Note that the physics of this problem would be better modeled by $\dot{m}_e = k\sqrt{H(t)}$, as we shall see later in Ch. 7.2.3. However, near the equilibrium state, our linear analysis can be shown to be appropriate. A better capture of the initial transients would require the indicated modifications, and would necessitate a numerical solution, rather than the closed form analytic solution given here.

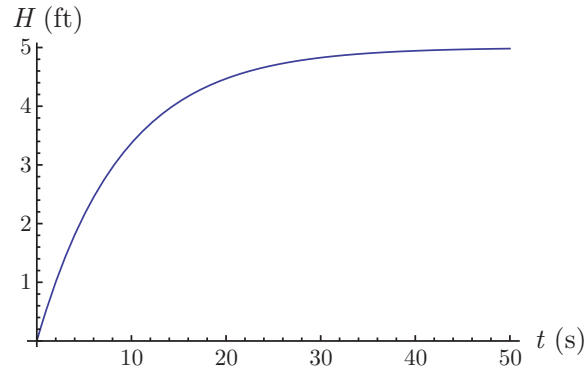

Figure 4.12: Plot of $H(t)$ for transient tank filling problem.

4.1.2.2 Energy

For energy, we must consider the *total energy* that includes internal, kinetic, and potential. Our extensive property B is thus

$$B = E = U + \frac{1}{2}m\mathbf{v} \cdot \mathbf{v} + mgz. \quad (4.125)$$

Here, we have assumed the fluid resides in a gravitational potential field in which the gravitational potential energy varies linearly with height z . The corresponding intensive property β is

$$\beta = e = u + \frac{1}{2}\mathbf{v} \cdot \mathbf{v} + gz. \quad (4.126)$$

We recall the first law of thermodynamics, that states the change of a material volume's total energy is equal to the heat transferred to the material volume less the work done by the material volume. Mathematically, this is stated as Eq. (3.160):

$$dE = \delta Q - \delta W. \quad (4.127)$$

We recall the total derivative is used for dE , because energy is a property and has an exact differential, while both heat transfer and work are not properties and do not have exact differentials. It is more convenient to express the first law as a rate equation, that we get by dividing (4.127) by dt to get

$$\frac{dE}{dt} = \frac{\delta Q}{dt} - \frac{\delta W}{dt}. \quad (4.128)$$

Recall that the upper case letters denote extensive thermodynamic properties. For example, E is total energy, inclusive of internal and kinetic and potential¹², with SI units of J. Let us consider each term in the first law of thermodynamics in detail and then write the equation in final form.

¹²Strictly speaking our derivation will only be valid for potentials that are time-independent. This is the case for ordinary gravitational potentials. The modifications for time-dependent potentials are straightforward, but require a more nuanced interpretation than space permits here.

4.1.2.2.1 Total energy term For a fluid particle, the differential amount of total energy is

$$dE = \rho \beta dV = \rho \underbrace{\left(u + \frac{1}{2} \mathbf{v} \cdot \mathbf{v} + gz \right)}_{\beta} dV, \quad (4.129)$$

$$= \underbrace{\rho dV}_{\text{mass}} \underbrace{\left(u + \frac{1}{2} \mathbf{v} \cdot \mathbf{v} + gz \right)}_{\text{internal + kinetic + potential}}. \quad (4.130)$$

4.1.2.2.2 Work term Let us partition the work into work W_P done by a pressure force \mathbf{F}_P and work done by other sources, that we shall call W_{mv} , where the subscript “ mv ” indicates “material volume.”

$$W = W_P + W_{mv}. \quad (4.131)$$

Taking a time derivative, we get

$$\frac{\delta W}{dt} = \frac{\delta W_P}{dt} + \dot{W}_{mv}. \quad (4.132)$$

The work done by other sources is often called *shaft work* and represents inputs of such devices as compressors, pumps, and turbines. Its modeling is often not rigorous.

Recall that work is done when a force acts through a distance, and a work rate arises when a force acts through a distance at a particular rate in time (hence, a velocity is involved). Recall also that it is the dot product of the force vector with the position or velocity that gives the true work or work rate. In shorthand, we can say that the differential work done by the pressure force \mathbf{F}_P is

$$\delta W_P = \mathbf{F}_P \cdot d\mathbf{x}, \quad (4.133)$$

$$\frac{\delta W_P}{dt} = \mathbf{F}_P \cdot \frac{d\mathbf{x}}{dt} = \mathbf{F}_P \cdot \mathbf{v}. \quad (4.134)$$

Here, W has the SI units of J, and \mathbf{F}_P has the SI units of N. Now, let us consider the work done by the pressure force. In a piston-cylinder arrangement in which a fluid exists with pressure P within the cylinder and the piston is rising with velocity \mathbf{v} , the work rate done by the fluid is positive. We can think of the local stress vector in the fluid as pointing in the same direction as the fluid is moving at the piston surface, so that the dot product is positive. Now, we can express the pressure force in terms of the pressure by

$$\mathbf{F}_P = P A \mathbf{n}. \quad (4.135)$$

Substituting (4.134) into (4.135), we get

$$\frac{\delta W_P}{dt} = P A \mathbf{n} \cdot \mathbf{v}. \quad (4.136)$$

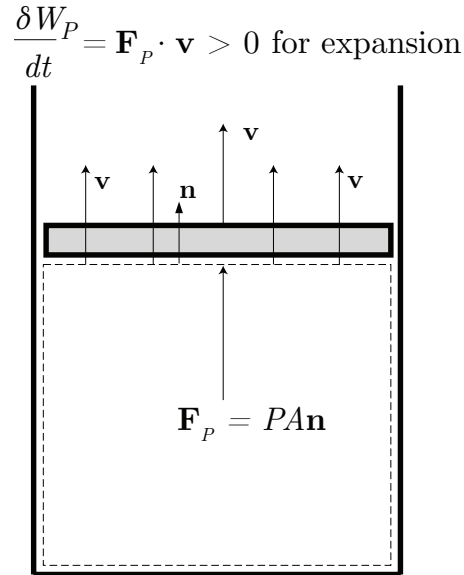

Figure 4.13: Sketch of fluid doing work.

It is noted that we have been a little loose distinguishing local areas from global areas. Better stated, we should say for a material volume that

$$\frac{\delta W_P}{dt} = \int_{A_m(t)} P \mathbf{n} \cdot \mathbf{v} dA. \quad (4.137)$$

This form allows for P and \mathbf{v} to vary with location. This is summarized in the sketch of Fig. 4.13.

4.1.2.2.3 Heat transfer term If we were considering temperature fields with spatial dependency, we would define a heat flux vector. This approach is absolutely necessary to describe many real-world devices, and is the focus of a standard undergraduate course in heat transfer. Here, we will take a simplified assumption that the only heat fluxes are easily specified and are all absorbed into a lumped scalar term we will call \dot{Q}_{mv} . This term has units of $\text{J/s} = \text{W}$ in SI. So we have then

$$\frac{\delta Q}{dt} = \dot{Q}_{mv}. \quad (4.138)$$

4.1.2.2.4 The first law of thermodynamics Putting the words of the first law into equation form, we get

$$\frac{d}{dt} \underbrace{\int_{V_m(t)} \rho \left(u + \frac{1}{2} \mathbf{v} \cdot \mathbf{v} + gz \right) dV}_{E_{mv}} = \frac{\delta Q}{dt} - \frac{\delta W}{dt}. \quad (4.139)$$

We next introduce our simplification of heat transfer (4.138) and partition of work (4.132) along with (4.137) into (4.139) to get

$$\frac{d}{dt} \int_{V_m(t)} \rho \left(u + \frac{1}{2} \mathbf{v} \cdot \mathbf{v} + gz \right) dV = \dot{Q}_{mv} - \underbrace{\left(\dot{W}_{mv} + \int_{A_m(t)} P \mathbf{n} \cdot \mathbf{v} dA \right)}_{=\delta W/dt}. \quad (4.140)$$

Now, we bring the pressure work integral to the right side of (4.140) to get

$$\frac{d}{dt} \int_{V_m(t)} \rho \left(u + \frac{1}{2} \mathbf{v} \cdot \mathbf{v} + gz \right) dV + \int_{A_m(t)} P \mathbf{n} \cdot \mathbf{v} dA = \dot{Q}_{mv} - \dot{W}_{mv}. \quad (4.141)$$

We next invoke the Reynolds transport theorem (4.43) into (4.141) to expand the derivative of the first integral so as to obtain

$$\underbrace{\int_{V_m(t)} \frac{\partial}{\partial t} \left(\rho \left(u + \frac{1}{2} \mathbf{v} \cdot \mathbf{v} + gz \right) \right) dV + \int_{A_m(t)} \left(\rho \left(u + \frac{1}{2} \mathbf{v} \cdot \mathbf{v} + gz \right) \right) \mathbf{v} \cdot \mathbf{n} dA}_{dE_{mv}/dt} + \int_{A_m(t)} P \mathbf{n} \cdot \mathbf{v} dA = \dot{Q}_{mv} - \dot{W}_{mv}. \quad (4.142)$$

We next note that the two surface integrals have the same limits and can be combined to form

$$\int_{V_m(t)} \frac{\partial}{\partial t} \left(\rho \left(u + \frac{1}{2} \mathbf{v} \cdot \mathbf{v} + gz \right) \right) dV + \int_{A_m(t)} \left(\rho \left(\underbrace{u + \frac{P}{\rho}}_h + \frac{1}{2} \mathbf{v} \cdot \mathbf{v} + gz \right) \right) \mathbf{v} \cdot \mathbf{n} dA = \dot{Q}_{mv} - \dot{W}_{mv}. \quad (4.143)$$

We recall now the definition of enthalpy h , Eq. (3.204),

$$h = u + \frac{P}{\rho} = u + Pv. \quad (4.144)$$

Invoking (4.144) into (4.143), we get

$$\int_{V_m(t)} \frac{\partial}{\partial t} \left(\rho \left(u + \frac{1}{2} \mathbf{v} \cdot \mathbf{v} + gz \right) \right) dV + \int_{A_m(t)} \left(\rho \left(h + \frac{1}{2} \mathbf{v} \cdot \mathbf{v} + gz \right) \right) \mathbf{v} \cdot \mathbf{n} dA = \dot{Q}_{mv} - \dot{W}_{mv}. \quad (4.145)$$

Next use the divergence theorem (4.2) to rewrite (4.145) as

$$\int_{V_m(t)} \frac{\partial}{\partial t} \left(\rho \left(u + \frac{1}{2} \mathbf{v} \cdot \mathbf{v} + gz \right) \right) dV + \int_{V_m(t)} \nabla \cdot \left(\rho \mathbf{v} \left(h + \frac{1}{2} \mathbf{v} \cdot \mathbf{v} + gz \right) \right) dV = \dot{Q}_{mv} - \dot{W}_{mv}. \quad (4.146)$$

Now, for convenience, let us define the specific heat transfer and work, q_{mv} and w_{mv} , each with SI units J/kg such that

$$\dot{Q}_{mv} = \int_{V_m(t)} \frac{\partial}{\partial t} (\rho q_{mv}) dV, \quad (4.147)$$

$$\dot{W}_{mv} = \int_{V_m(t)} \frac{\partial}{\partial t} (\rho w_{mv}) dV, \quad (4.148)$$

so that by substituting (4.147) and (4.148) into (4.146), we get

$$\begin{aligned} \int_{V_m(t)} \frac{\partial}{\partial t} \left(\rho \left(u + \frac{1}{2} \mathbf{v} \cdot \mathbf{v} + gz \right) \right) dV + \int_{V_m(t)} \nabla \cdot \left(\rho \mathbf{v} \left(h + \frac{1}{2} \mathbf{v} \cdot \mathbf{v} + gz \right) \right) dV \\ = \int_{V_m(t)} \frac{\partial}{\partial t} (\rho q_{mv}) dV - \int_{V_m(t)} \frac{\partial}{\partial t} (\rho w_{mv}) dV. \end{aligned} \quad (4.149)$$

Now, all terms in (4.149) have the same limits of integration, so they can be grouped to form

$$\begin{aligned} \int_{V_m(t)} \left(\frac{\partial}{\partial t} \left(\rho \left(u + \frac{1}{2} \mathbf{v} \cdot \mathbf{v} + gz \right) \right) + \nabla \cdot \left(\rho \mathbf{v} \left(h + \frac{1}{2} \mathbf{v} \cdot \mathbf{v} + gz \right) \right) \right. \\ \left. - \frac{\partial}{\partial t} (\rho q_{mv}) + \frac{\partial}{\partial t} (\rho w_{mv}) \right) dV = 0. \end{aligned} \quad (4.150)$$

As with the mass equation, because the integral is zero, in general we must expect the integrand to be zero, giving us

$$\frac{\partial}{\partial t} \left(\rho \left(u + \frac{1}{2} \mathbf{v} \cdot \mathbf{v} + gz \right) \right) + \nabla \cdot \left(\rho \mathbf{v} \left(h + \frac{1}{2} \mathbf{v} \cdot \mathbf{v} + gz \right) \right) - \frac{\partial}{\partial t} (\rho q_{mv}) + \frac{\partial}{\partial t} (\rho w_{mv}) = 0. \quad (4.151)$$

To get the standard control volume form of the equation, we then integrate (4.151) over a *fixed* control volume V to get

$$\begin{aligned} \int_V \left(\frac{\partial}{\partial t} \left(\rho \left(u + \frac{1}{2} \mathbf{v} \cdot \mathbf{v} + gz \right) \right) + \nabla \cdot \left(\rho \mathbf{v} \left(h + \frac{1}{2} \mathbf{v} \cdot \mathbf{v} + gz \right) \right) \right. \\ \left. - \frac{\partial}{\partial t} (\rho q_{mv}) + \frac{\partial}{\partial t} (\rho w_{mv}) \right) dV = 0. \end{aligned} \quad (4.152)$$

Now, defining the heat transfer and work rates, \dot{Q}_{cv} and \dot{W}_{cv} ,

$$\dot{Q}_{cv} = \int_V \frac{\partial}{\partial t} (\rho q_{mv}) dV, \quad (4.153)$$

$$\dot{W}_{cv} = \int_V \frac{\partial}{\partial t} (\rho w_{mv}) dV, \quad (4.154)$$

we employ (4.153) and (4.154) in (4.152) to get

$$\int_V \left(\frac{\partial}{\partial t} \left(\rho \left(u + \frac{1}{2} \mathbf{v} \cdot \mathbf{v} + gz \right) \right) + \nabla \cdot \left(\rho \mathbf{v} \left(h + \frac{1}{2} \mathbf{v} \cdot \mathbf{v} + gz \right) \right) \right) dV = \dot{Q}_{cv} - \dot{W}_{cv} \quad (4.155)$$

Applying the divergence theorem (4.2) to (4.155) to convert a portion of the volume integral into a surface integral, and (4.47) to bring the time derivative outside the integral for the fixed volume, we get

$$\frac{d}{dt} \underbrace{\int_V \rho \left(u + \frac{1}{2} \mathbf{v} \cdot \mathbf{v} + gz \right) dV}_{E_{cv}} + \int_A \rho \mathbf{v} \cdot \mathbf{n} \left(h + \frac{1}{2} \mathbf{v} \cdot \mathbf{v} + gz \right) dA = \dot{Q}_{cv} - \dot{W}_{cv}. \quad (4.156)$$

We now define the total energy in the control volume as

$$E_{cv} = \int_V \rho \left(u + \frac{1}{2} \mathbf{v} \cdot \mathbf{v} + gz \right) dV. \quad (4.157)$$

Next assume that all properties across entrances and exits are uniform so that the surface integral in (4.156) reduces to

$$\int_A \rho \mathbf{v} \cdot \mathbf{n} \left(h + \frac{1}{2} \mathbf{v} \cdot \mathbf{v} + gz \right) dA = \sum \dot{m}_e \left(h_e + \frac{1}{2} \mathbf{v}_e \cdot \mathbf{v}_e + gz_e \right) - \sum \dot{m}_i \left(h_i + \frac{1}{2} \mathbf{v}_i \cdot \mathbf{v}_i + gz_i \right). \quad (4.158)$$

Substituting (4.157) and (4.158) into (4.156), we get

$$\frac{dE_{cv}}{dt} + \sum \dot{m}_e \left(h_e + \frac{1}{2} \mathbf{v}_e \cdot \mathbf{v}_e + gz_e \right) - \sum \dot{m}_i \left(h_i + \frac{1}{2} \mathbf{v}_i \cdot \mathbf{v}_i + gz_i \right) = \dot{Q}_{cv} - \dot{W}_{cv}. \quad (4.159)$$

Rearranging (4.159), we get

$$\underbrace{\frac{dE_{cv}}{dt}}_{\text{rate of CV energy change}} = \underbrace{\dot{Q}_{cv}}_{\text{CV heat transfer rate}} - \underbrace{\dot{W}_{cv}}_{\text{CV shaft work rate}} + \underbrace{\sum \dot{m}_i \left(h_i + \frac{1}{2} \mathbf{v}_i \cdot \mathbf{v}_i + gz_i \right)}_{\text{total enthalpy rate in}} - \underbrace{\sum \dot{m}_e \left(h_e + \frac{1}{2} \mathbf{v}_e \cdot \mathbf{v}_e + gz_e \right)}_{\text{total enthalpy rate out}} \quad (4.160)$$

Here, (4.160) is equivalent to BS's Eq. (4.7), p. 148. Note that the so-called *total enthalpy* is often defined as

$$h_{tot} = h + \frac{1}{2} \mathbf{v} \cdot \mathbf{v} + gz. \quad (4.161)$$

Employing (4.161) in (4.160), we find

$$\boxed{\frac{dE_{cv}}{dt} = \dot{Q}_{cv} - \dot{W}_{cv} + \sum \dot{m}_i h_{tot,i} - \sum \dot{m}_e h_{tot,e}.} \quad (4.162)$$

Here, (4.162) is equivalent to BS's (4.8), p. 148.

If there is a single entrance and exit, we lose the summation, so that (4.160) becomes

$$\frac{dE_{cv}}{dt} = \dot{Q}_{cv} - \dot{W}_{cv} + \dot{m}_i \left(h_i + \frac{1}{2} \mathbf{v}_i \cdot \mathbf{v}_i + gz_i \right) - \dot{m}_e \left(h_e + \frac{1}{2} \mathbf{v}_e \cdot \mathbf{v}_e + gz_e \right). \quad (4.163)$$

If the flow is steady, we have $dE_{cv}/dt = 0$ and $\dot{m}_i = \dot{m}_e = \dot{m}$, so the first law with a single entrance and exit becomes

$$0 = \dot{Q}_{cv} - \dot{W}_{cv} + \dot{m} \left(h_i - h_e + \frac{1}{2} (\mathbf{v}_i \cdot \mathbf{v}_i - \mathbf{v}_e \cdot \mathbf{v}_e) + g(z_i - z_e) \right). \quad (4.164)$$

Defining the specific heat transfer and work as

$$q = \frac{\dot{Q}_{cv}}{\dot{m}}, \quad w = \frac{\dot{W}_{cv}}{\dot{m}}, \quad (4.165)$$

and substituting (4.165) into (4.164), we get

$$0 = q - w + h_i - h_e + \frac{1}{2} (\mathbf{v}_i \cdot \mathbf{v}_i - \mathbf{v}_e \cdot \mathbf{v}_e) + g(z_i - z_e). \quad (4.166)$$

Now, (4.166) can be rearranged to form BS's (4.13), p. 149:

$$\boxed{q + h_i + \frac{1}{2} \mathbf{v}_i \cdot \mathbf{v}_i + gz_i = w + h_e + \frac{1}{2} \mathbf{v}_e \cdot \mathbf{v}_e + gz_e.} \quad (4.167)$$

This looks more like the first law when we rearrange as

$$\left(h_e + \frac{1}{2} \mathbf{v}_e \cdot \mathbf{v}_e + gz_e \right) - \left(h_i + \frac{1}{2} \mathbf{v}_i \cdot \mathbf{v}_i + gz_i \right) = q - w. \quad (4.168)$$

If the flow is adiabatic, steady, has one entrance and one exit, and there is no shaft work, we find that the total enthalpy must remain constant:

$$h_i + \frac{1}{2} \mathbf{v}_i \cdot \mathbf{v}_i + gz_i = h_e + \frac{1}{2} \mathbf{v}_e \cdot \mathbf{v}_e + gz_e. \quad (4.169)$$

4.2 Mass conservation in brief

Here, we summarize the key equations for mass conservation derived in the previous section. We consider the mass enclosed in a fixed control volume V , Eq. (4.87):

$$m_{cv} = \int_V \rho dV. \quad (4.170)$$

The density ρ can vary throughout V . In this class, we will nearly always take it to be constant throughout the volume. If ρ is constant throughout V , then it can be brought outside the integral operator, yielding $m_{cv} = \rho \int_V dV = \rho V$. Our control volume will have a finite number of openings where fluid can enter and exit.

We state mass conservation for a control volume as

$$\underbrace{\frac{dm_{cv}}{dt}}_{\text{rate of change of mass}} = \underbrace{\sum \rho_i |\mathbf{v}_i| A_i}_{\text{mass rate in}} - \underbrace{\sum \rho_e |\mathbf{v}_e| A_e}_{\text{mass rate out}}, \quad (4.171)$$

$$\boxed{\underbrace{\frac{dm_{cv}}{dt}}_{\text{rate of change of mass}} = \underbrace{\sum \dot{m}_i}_{\text{mass rate in}} - \underbrace{\sum \dot{m}_e}_{\text{mass rate out}}.} \quad (4.172)$$

Equations (4.171, 4.172) were fully developed in the previous section where they appeared as Eqs. (4.93, 4.94). Here, the fluid at an inlet i has density ρ_i , velocity vector \mathbf{v}_i and flows through cross-sectional area A_i . An analogous set of variables exists at each exit e . Let us look at the units of the important quantity $\rho|\mathbf{v}|A$:

$$\rho|\mathbf{v}|A \rightarrow \frac{\text{kg}}{\text{m}^3} \frac{\text{m}}{\text{s}} \text{m}^2 = \frac{\text{kg}}{\text{s}}. \quad (4.173)$$

Obviously, it is a rate of mass flow; consequently, we define the mass flow rate as

$$\dot{m} \equiv \rho|\mathbf{v}|A. \quad (4.174)$$

Often we will neglect the vector notation and take $|\mathbf{v}| = v$. Equation (4.172) expresses mathematically the notion of mass conservation for the control volume:

- *The time rate of accumulation of mass within the control volume is equal to the net rate of mass flow into the control volume.*

In short

$$\text{accumulation} = \text{in} - \text{out}.$$

In the important case in which there is no net accumulation rate, the so-called *steady state* limit, we get

$$\underbrace{\frac{dm_{cv}}{dt}}_{=0} = \sum \dot{m}_i - \sum \dot{m}_e. \quad (4.175)$$

$$\boxed{\sum \dot{m}_i = \sum \dot{m}_e} \quad (4.176)$$

Eq. (4.176) is the same as Eq. (4.96). If there is a single entrance and exit, then we simply get

$$\dot{m}_i = \dot{m}_e = \dot{m} = \text{constant}. \quad (4.177)$$

4.3 Energy conservation in brief

We can state the first law of thermodynamics for a control volume as

$$\underbrace{\frac{dE_{cv}}{dt}}_{\text{rate of CV energy change}} = \underbrace{\dot{Q}_{cv}}_{\text{CV heat transfer rate}} - \underbrace{\dot{W}_{cv}}_{\text{CV shaft work rate}} + \underbrace{\sum \dot{m}_i \left(h_i + \frac{1}{2}v_i^2 + gz_i \right)}_{\text{total enthalpy rate in}} - \underbrace{\sum \dot{m}_e \left(h_e + \frac{1}{2}v_e^2 + gz_e \right)}_{\text{total enthalpy rate out}}. \quad (4.178)$$

Here, Eq. (4.178) is equivalent Eq. (4.160) and to BS's Eq. (4.7), p. 148. Note that the so-called *total enthalpy* is often defined as

$$h_{tot} = h + \frac{1}{2}v^2 + gz = u + \frac{1}{2}v^2 + gz + Pv. \quad (4.179)$$

Note that in this context, total enthalpy is on a per mass basis. The “total” comes from summing internal, kinetic, potential, and Pv terms. Employing (4.179) in (4.178), we find

$$\boxed{\frac{dE_{cv}}{dt} = \dot{Q}_{cv} - \dot{W}_{cv} + \sum \dot{m}_i h_{tot,i} - \sum \dot{m}_e h_{tot,e}} \quad (4.180)$$

Here, Eq. (4.180) is equivalent to Eq. (4.162) and to BS's (4.8), p. 148. Eq. (4.180) expresses mathematically the notion of energy conservation for the control volume:

- *The time rate of accumulation of total energy within the control volume is equal the rate of heat transfer into the control volume minus the rate of work done leaving the control volume plus the net rate of total enthalpy entering the control volume.*

The new terms here are attributable to total enthalpy entering and exiting the control volume.

Again, the total enthalpy is the sum of the specific internal energy, the specific kinetic energy, the specific potential energy and the term Pv . It is easy to imagine that E_{cv} , that itself is composed of u , KE , and PE , is affected by the flow of u , KE , and PE into and out of the control volume. However the term Pv is unusual. It is multiplied by \dot{m} . Let us check the units:

$$\dot{m}Pv \rightarrow \left(\frac{\text{kg}}{\text{s}} \right) \left(\frac{\text{kN}}{\text{m}^2} \right) \left(\frac{\text{m}^3}{\text{kg}} \right) = \frac{\text{kJ}}{\text{s}} = \text{kW}. \quad (4.181)$$

It has the units of power. As shown in detail in the previous section,

- The term $\dot{m}Pv$ embedded within the control volume energy equation within h_{tot} accounts for the net work rate done by the fluid as it enters and exits the control surface bounding the control volume.
- The term \dot{W}_{cv} represents so-called shaft work and does not include work associated with the expansion of the working fluid.

If there is a single entrance and exit, we lose the summation, so that (4.178) becomes

$$\frac{dE_{cv}}{dt} = \dot{Q}_{cv} - \dot{W}_{cv} + \dot{m}_i \left(h_i + \frac{1}{2}v_i^2 + gz_i \right) - \dot{m}_e \left(h_e + \frac{1}{2}v_e^2 + gz_e \right). \quad (4.182)$$

If the flow is steady, we have $dE_{cv}/dt = 0$ and $\dot{m}_i = \dot{m}_e = \dot{m}$, so the first law with a single entrance and exit becomes

$$0 = \dot{Q}_{cv} - \dot{W}_{cv} + \dot{m} \left(h_i - h_e + \frac{1}{2}(v_i^2 - v_e^2) + g(z_i - z_e) \right). \quad (4.183)$$

Defining the specific heat transfer and work as

$$q = \frac{\dot{Q}_{cv}}{\dot{m}}, \quad w = \frac{\dot{W}_{cv}}{\dot{m}}, \quad (4.184)$$

and substituting (4.184) into (4.183), we get

$$0 = q - w + h_i - h_e + \frac{1}{2}(v_i^2 - v_e^2) + g(z_i - z_e). \quad (4.185)$$

Now, (4.185) can be rearranged to form BS's (4.13), p. 149:

$$q + h_i + \frac{1}{2}v_i^2 + gz_i = w + h_e + \frac{1}{2}v_e^2 + gz_e. \quad (4.186)$$

This looks more like the first law when we rearrange as

$$\underbrace{\left(h_e + \frac{1}{2}v_e^2 + gz_e \right)}_{\text{outlet}} = \underbrace{\left(h_i + \frac{1}{2}v_i^2 + gz_i \right)}_{\text{inlet}} + \underbrace{q - w}_{\text{CV heat and work}}. \quad (4.187)$$

If the flow is adiabatic, steady, has one entrance and one exit, and there is no shaft work, we find that the total enthalpy must remain constant:

$$h_i + \frac{1}{2}v_i^2 + gz_i = h_e + \frac{1}{2}v_e^2 + gz_e. \quad (4.188)$$

Example 4.7

A well insulated chamber with $V = 1 \text{ ft}^3$ initially contains air at $P = 14.7 \text{ lbf/in}^2$, $T = 100 \text{ }^\circ\text{F}$. See Fig. 4.14. Intake and exhaust valves are opened, and air enters and exits at 1 lbm/min through each

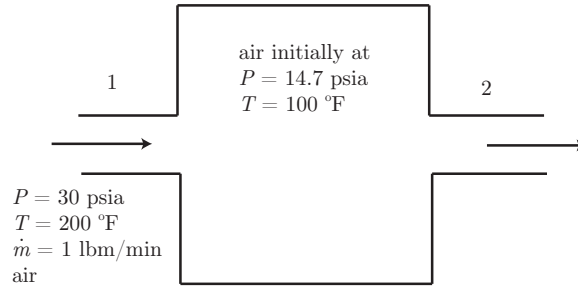

Figure 4.14: Sketch of transient thermal mixing problem.

valve. The entering air is at $P = 30 \text{ lbf/in}^2$, $T = 200 \text{ }^\circ\text{F}$. Assume the air is well mixed so that P and T are uniform throughout the chamber. Find $P(t)$, $T(t)$.

The temperatures are moderate, so it is not a problem to model air as a CPIG. For a CPIG, we have

$$P \frac{V}{m} = RT, \quad (4.189)$$

$$dh = c_P dT, \quad (4.190)$$

$$du = c_v dT. \quad (4.191)$$

The mass and energy evolution equations for the control volume are, respectively,

$$\frac{dm_{cv}}{dt} = \dot{m}_1 - \dot{m}_2, \quad (4.192)$$

$$\frac{dE_{cv}}{dt} = \dot{Q}_{cv} - \dot{W}_{cv} + \dot{m}_1 \left(h_1 + \frac{v_1^2}{2} + gz_1 \right) - \dot{m}_2 \left(h_2 + \frac{v_2^2}{2} + gz_2 \right). \quad (4.193)$$

Let us find the initial mass in the control volume. At $t = 0 \text{ s}$, we have

$$m = \frac{PV}{RT} = \frac{PV}{\bar{R}T} = \frac{(14.7 \frac{\text{lbf}}{\text{in}^2}) (144 \frac{\text{in}^2}{\text{ft}^2}) (1 \text{ ft}^3)}{\frac{1545 \frac{\text{lbf} \cdot \text{ft}}{\text{lbmole} \cdot \text{ }^\circ\text{R}}}{28.97 \frac{\text{lbm}}{\text{lbmole}}} (100 + 460 \text{ }^\circ\text{R})} = 0.0709 \text{ lbm}. \quad (4.194)$$

Now, the mass balance gives

$$\frac{dm_{cv}}{dt} = \dot{m}_1 - \dot{m}_2, \quad (4.195)$$

with $\dot{m}_1 = \dot{m}_2 = (1 \text{ lbm/min})(\text{min}/60 \text{ s}) = (1/60) \text{ lbm/s}$.

$$\frac{dm_{cv}}{dt} = \left(\frac{1}{60} \frac{\text{lbm}}{\text{s}} \right) - \left(\frac{1}{60} \frac{\text{lbm}}{\text{s}} \right) = 0, \quad (4.196)$$

$$m_{cv} = \text{constant} = 0.0709 \text{ lbm}. \quad (4.197)$$

Now, for the energy equation, we can neglect changes in kinetic and potential energies. The volume is insulated, so $\dot{Q}_{cv} = 0$. And there is no shaft work, so $\dot{W}_{cv} = 0$. So the energy balance reduces to

$$\frac{dE_{cv}}{dt} = \dot{m}_1 h_1 - \dot{m}_2 h_2. \quad (4.198)$$

Now, because $\dot{m}_1 = \dot{m}_2 = \dot{m}$, and because $E_{cv} = U_{cv} = m_{cv}u_{cv}$ when KE and PE are neglected, the energy equation reduces to

$$\frac{d}{dt}(m_{cv}u_{cv}) = \dot{m}(h_1 - h_2). \quad (4.199)$$

Because m_{cv} is constant, and because $du = c_v dT$, where c_v is constant for a CPIG, we get

$$m_{cv}c_v \frac{dT_{cv}}{dt} = \dot{m}(h_1 - h_2). \quad (4.200)$$

Now, h_1 is known from the inlet conditions. After mixing, the exit enthalpy takes on the value of the enthalpy in the chamber. So we have from the caloric equation of state for h that

$$h_1 - h_2 = c_P(T_1 - T_{cv}). \quad (4.201)$$

Thus, the energy equation becomes

$$m_{cv}c_v \frac{dT_{cv}}{dt} = \dot{m}c_P(T_1 - T_{cv}). \quad (4.202)$$

We also have the initial condition $T(0) = T_o$. We rewrite the energy equation, Eq. (4.202), as

$$\frac{dT_{cv}}{dt} = \frac{\dot{m}}{m_{cv}} \underbrace{\frac{c_P}{c_v}}_{=k} (T_1 - T_{cv}), \quad (4.203)$$

$$= \frac{\dot{m}}{m_{cv}} k (T_1 - T_{cv}). \quad (4.204)$$

Note the temperature is equilibrated when $T_{cv} = T_1$. We expect after a long time that the entire system acquires the character of the inlet after all the old material is flushed from the control volume. The question now is how long is the flushing time? To answer this, we must solve a differential equation. Let us separate variables to get

$$\frac{dT_{cv}}{T_1 - T_{cv}} = \frac{\dot{m}}{m_{cv}} k dt, \quad (4.205)$$

$$-\ln(T_1 - T_{cv}) = \frac{\dot{m}}{m_{cv}} kt + C, \quad (4.206)$$

$$T_1 - T_{cv} = \exp\left(-\frac{\dot{m}}{m_{cv}} kt - C\right), \quad (4.207)$$

$$T_1 - T_{cv} = C' \exp\left(-\frac{\dot{m}}{m_{cv}} kt\right). \quad (4.208)$$

At the initial state, we get

$$T_1 - T_o = C'. \quad (4.209)$$

Thus

$$T_{cv} = T_1 - (T_1 - T_o) \exp\left(-\frac{\dot{m}}{m_{cv}} kt\right). \quad (4.210)$$

Note that as $t \rightarrow \infty$, $T_{cv} \rightarrow T_1$. Also note by inspection, the time constant of relaxation is

$$\tau = \frac{m_{cv}}{\dot{m}} \frac{1}{k}. \quad (4.211)$$

So the time to equilibrium is short if

- the input forcing \dot{m} is large, or
- the mass in the control volume, m_{cv} , is small.

For us, the time constant is

$$\tau = \frac{0.0709 \text{ lbm}}{\left(\frac{7}{5}\right) \left(\frac{1}{60} \frac{\text{lbm}}{\text{s}}\right)} = 3.04 \text{ s.} \quad (4.212)$$

So the temperature variation is

$$T_{cv}(t) = (660 \text{ }^\circ\text{R}) - ((660 \text{ }^\circ\text{R}) - (560 \text{ }^\circ\text{R})) \exp\left(-\frac{t}{3.04 \text{ s}}\right). \quad (4.213)$$

$$\boxed{T_{cv}(t) = (660 \text{ }^\circ\text{R}) - (100 \text{ }^\circ\text{R}) \exp\left(-\frac{t}{3.04 \text{ s}}\right).} \quad (4.214)$$

For the pressure, we have $PV = mRT$, so

$$P_{cv}(t) = \frac{mRT_{cv}(t)}{V}, \quad (4.215)$$

$$= \frac{(0.0709 \text{ lbm}) \left(\frac{1545 \frac{\text{ft} \cdot \text{lb}_f}{\text{lbmole} \cdot \text{ }^\circ\text{R}}}{28.97 \frac{\text{lbm}}{\text{lbmole}}}\right) ((660 \text{ }^\circ\text{R}) - (100 \text{ }^\circ\text{R}) \exp(-\frac{t}{3.04 \text{ s}})) \frac{\text{ft}^2}{144 \text{ in}^2}}{1 \text{ ft}^3}. \quad (4.216)$$

So the pressure is

$$\boxed{P_{cv}(t) = (17.33 \text{ psia}) - (2.6258 \text{ psia}) \exp\left(-\frac{t}{3.04 \text{ s}}\right).} \quad (4.217)$$

A plot of $T(t)$ and $P(t)$ is given in Fig. 4.15. Note, the final pressure is not the inlet pressure.

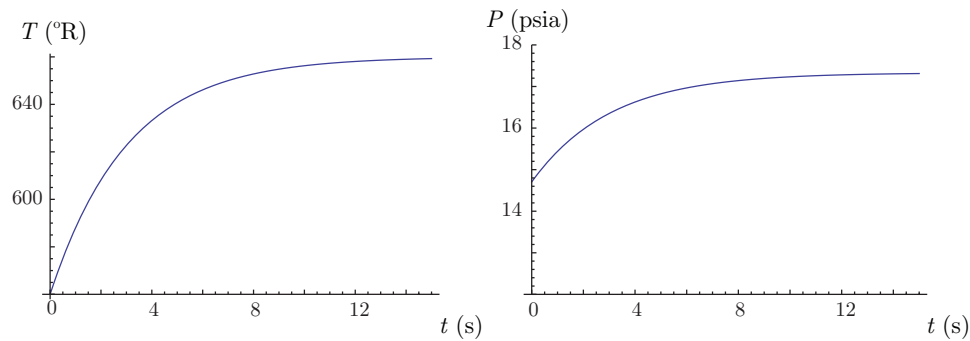

Figure 4.15: Plots of $T(t)$ and $P(t)$ for transient thermal mixing problem.

4.4 Some devices

Here, we will consider rudiments of control volume analysis for some common engineering devices.

4.4.1 Throttling device

A flow is throttled when, for example, it flows through a partially open valve. When it does so, we notice that there can be a significant pressure loss from one side of the partially open valve to the other. A sketch of a throttling device is given in Fig. 4.16.

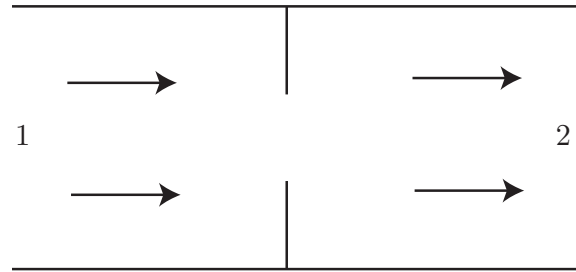

Figure 4.16: Sketch of throttling device.

We model a throttling device as steady with one entrance and exit, with no control volume work or heat transfer. We neglect changes in area as well as potential energy. Mass conservation tells us

$$\underbrace{\frac{dm_{cv}}{dt}}_{=0} = \dot{m}_1 - \dot{m}_2, \quad (4.218)$$

$$0 = \dot{m}_1 - \dot{m}_2, \quad (4.219)$$

$$\dot{m}_1 = \dot{m}_2 = \dot{m}. \quad (4.220)$$

Energy conservation tells us that

$$\underbrace{\frac{dE_{cv}}{dt}}_{=0} = \underbrace{\dot{Q}_{cv}}_{=0} - \underbrace{\dot{W}_{cv}}_{=0} + \dot{m}_1 \left(h_1 + \frac{v_1^2}{2} + gz_1 \right) - \dot{m}_2 \left(h_2 + \frac{v_2^2}{2} + gz_2 \right), \quad (4.221)$$

$$0 = \dot{m} \left(h_1 - h_2 + \underbrace{\frac{v_1^2}{2} - \frac{v_2^2}{2}}_{\sim 0} + \underbrace{gz_1 - gz_2}_{=0} \right). \quad (4.222)$$

Now, in throttling devices there may be a change in velocity due to compressibility effects, but it is observed to be small when the flow velocity is much less than the speed of sound. We shall assume here the velocity is small relative to the speed of sound so as to recover $v_1 \sim v_2$ and thus

$$h_1 = h_2. \quad (4.223)$$

So, we can say that such a throttling device is one in which pressure drops and enthalpy remains constant.

Example 4.8

Let us throttle steam from $P_1 = 3$ bar, $T_1 = 200$ °C to $P_2 = 1$ bar. Find T_2 .

We know two properties at state 1; therefore, its state is determined. At state 2, we know the pressure and something about the path of the process that brought us to state 2. The process was iso-enthalpic, so $h_2 = h_1$. From the tables, we find

$$h_1 = 2865.5 \frac{\text{kJ}}{\text{kg}} = h_2. \quad (4.224)$$

So at state 2, we have $P_2 = 1$ bar, $h_2 = 2865.5$ kJ/kg. We interpolate the steam tables to find

$$\boxed{T_2 = 195.04 \text{ °C.}} \quad (4.225)$$

Note for steam, the enthalpy remained constant, but the temperature dropped. If the material had been an ideal gas, the temperature drop would have been zero, because for ideal gases, the enthalpy is related only to temperature.

Example 4.9

Consider calorically perfect ideal air flowing in a duct at $P_1 = 100000$ Pa, $T_1 = 300$ K, $v_1 = 10$ m/s. Take $c_P = 1000$ J/kg/K. The air is throttled down by a valve to $P_2 = 90000$ Pa. Consider fully the effects of compressibility and kinetic energy, find the downstream state after throttling, and show the assumption that $h_2 \sim h_1$ (giving for the CPIG $T_2 \sim T_1$) is a good approximation for this flow.

From the ideal gas law we get

$$\rho_1 = \frac{P_1}{RT_1} = \frac{100000 \text{ Pa}}{\left(287 \frac{\text{J}}{\text{kg K}}\right) (300 \text{ K})} = 1.16144 \frac{\text{kg}}{\text{m}^3}. \quad (4.226)$$

We write the mass, energy, thermal and caloric state equations as

$$\rho_2 v_2 = \rho_1 v_1, \quad (4.227)$$

$$h_2 + \frac{v_2^2}{2} = h_1 + \frac{v_1^2}{2}, \quad (4.228)$$

$$P_2 = \rho_2 R T_2, \quad (4.229)$$

$$h_2 - h_1 = c_P (T_2 - T_1). \quad (4.230)$$

This simplifies somewhat to

$$\rho_2 v_2 = \rho_1 v_1, \quad (4.231)$$

$$c_P T_2 + \frac{v_2^2}{2} = c_P T_1 + \frac{v_1^2}{2}, \quad (4.232)$$

$$P_2 = \rho_2 R T_2. \quad (4.233)$$

Substituting numbers, we get the system of non-linear algebraic equations

$$\rho_2 v_2 = \left(1.16144 \frac{\text{kg}}{\text{m}^3}\right) \left(10 \frac{\text{m}}{\text{s}}\right) = 11.6144 \frac{\text{kg}}{\text{m}^2 \text{s}}, \quad (4.234)$$

$$\left(1000 \frac{\text{J}}{\text{kg K}}\right) T_2 + \frac{v_2^2}{2} = \left(1000 \frac{\text{J}}{\text{kg K}}\right) (300 \text{ K}) + \frac{\left(10 \frac{\text{m}}{\text{s}}\right)^2}{2} = 300050 \frac{\text{J}}{\text{kg}}, \quad (4.235)$$

$$90000 \text{ Pa} = \rho_2 \left(287 \frac{\text{J}}{\text{kg K}}\right) T_2. \quad (4.236)$$

This forms three equations in the three unknowns ρ_2, T_2, v_2 . Detailed manipulation can reduce this to a quadratic equation, with two roots. The first root yields

$$\rho_2 = \boxed{1.04533 \frac{\text{kg}}{\text{m}^3}}, \quad (4.237)$$

$$T_2 = \boxed{299.988 \text{ K}}, \quad (4.238)$$

$$v_2 = \boxed{11.1107 \frac{\text{m}}{\text{s}}}. \quad (4.239)$$

This is the physical root. We see that

$$T_2 \sim T_1. \quad (4.240)$$

Thus, from the ideal gas law

$$\frac{\rho_2 T_2}{P_2} = \frac{\rho_1 T_1}{P_1}, \quad (4.241)$$

$$\rho_2 = \rho_1 \frac{T_1 P_2}{T_2 P_1}, \quad (4.242)$$

$$\sim \rho_1 \frac{P_2}{P_1}, \quad (4.243)$$

$$\sim \rho_1 \frac{90000 \text{ Pa}}{100000 \text{ Pa}}, \quad (4.244)$$

$$\sim 0.9 \rho_1, \quad (4.245)$$

$$\sim 0.9 \left(1.16144 \frac{\text{kg}}{\text{m}^3}\right), \quad (4.246)$$

$$\sim 1.0453 \frac{\text{kg}}{\text{m}^3}. \quad (4.247)$$

Then from mass conservation, we get

$$\rho_2 v_2 = \rho_1 v_1, \quad (4.248)$$

$$v_2 = v_1 \frac{\rho_1}{\rho_2}, \quad (4.249)$$

$$\sim v_1 \frac{1}{0.9}, \quad (4.250)$$

$$\sim \left(10 \frac{\text{m}}{\text{s}}\right) \frac{1}{0.9}, \quad (4.251)$$

$$\sim 11.11 \frac{\text{m}}{\text{s}}. \quad (4.252)$$

There is also an obviously non-physical root that is $\rho_2 = -0.000215037 \text{ kg/m}^3$, $T_2 = -1458300 \text{ K}$, $v_2 = -54011.1 \text{ m/s}$. Negative density and absolute temperature are physically unacceptable.

As an aside, detailed calculation reveals the exact solution for v_2 is

$$v_2 = \frac{c_P P_2 T_1 \left(\sqrt{\frac{P_1^2 v_1^2 (2c_P T_1 + v_1^2)}{c_P^2 P_2^2 T_1^2}} + 1 - 1 \right)}{P_1 v_1}. \quad (4.253)$$

This is a complicated expression that is difficult to interpret. But Taylor series expansion for $v_1^2/(c_P T_1) \ll 1$ yields

$$v_2 = v_1 \left(\frac{P_1}{P_2} \right) \left(1 + \left(1 - \left(\frac{P_1}{P_2} \right)^2 \right) \frac{v_1^2}{2c_P T_1} + \dots \right). \quad (4.254)$$

This is an excellent approximation that yields results fully equivalent to what was obtained earlier. Similarly, Taylor series of the solution for T_2 and ρ_2 in the same limit yields the approximations

$$T_2 = T_1 \left(1 + \left(1 - \left(\frac{P_1}{P_2} \right)^2 \right) \frac{v_1^2}{2c_P T_1} + \dots \right), \quad (4.255)$$

$$\rho_2 = \rho_1 \left(\frac{P_2}{P_1} \right) \left(1 - \left(1 - \left(\frac{P_1}{P_2} \right)^2 \right) \frac{v_1^2}{2c_P T_1} + \dots \right). \quad (4.256)$$

Direct substitution of the parameter values reveals that the approximations, relative to the exact solution, agree up to the fifth decimal place for v_2 , T_2 , and ρ_2 .

Example 4.10

A spacecraft returning to earth is traveling at $v = 10000$ m/s. It is in a region of the atmosphere where $T = 100$ K, $c_P = 1000$ J/kg/K. Neglecting any effects of shock waves, provide a simple estimate of the temperature at the nose of the vehicle.

In the laboratory frame, the atmosphere is at rest and the spacecraft is moving. Transform to the reference frame in which the spacecraft is at rest and is encountering air moving at 10000 m/s. As the air approaches the spacecraft, it decelerates to zero velocity at the nose. Take the 1 state to be the moving atmosphere and the 2 state to be the nose of the spacecraft. The first law of thermodynamics yields

$$h_1 + \frac{v_1^2}{2} = h_2 + \underbrace{\frac{v_2^2}{2}}_0, \quad (4.257)$$

$$h_2 - h_1 = \frac{v_1^2}{2}, \quad (4.258)$$

$$c_P(T_2 - T_1) = \frac{v_1^2}{2}, \quad (4.259)$$

$$T_2 = T_1 + \frac{v_1^2}{2c_P}, \quad (4.260)$$

$$= (100 \text{ K}) + \frac{(10^4 \frac{\text{m}}{\text{s}})^2}{2 \left(10^3 \frac{\text{J}}{\text{kg K}} \right)}, \quad (4.261)$$

$$= \boxed{50100 \text{ K}}. \quad (4.262)$$

This is a very high temperature. It is not a bad first estimate; however the actual temperature would be different because of neglected physics such as a) shock waves, b) temperature-dependent specific heat, c) dissociation and ionization of molecules.

4.4.2 Nozzles and diffusers

Similar to a throttling device, we model nozzles and diffusers as steady with one entrance and exit, with no control volume work. We may or may not neglect heat transfer. We neglect potential energy changes *but take kinetic energy changes into account*.

A nozzle is a device that induces a velocity increase; a diffuser is a device that induces a velocity decrease. For flows with subsonic velocities, nozzles have area decrease in the flow direction, while diffusers have area increases with the flow direction. We sketch these common configurations in Fig. 4.17. If one systematically applied the conservation of mass,

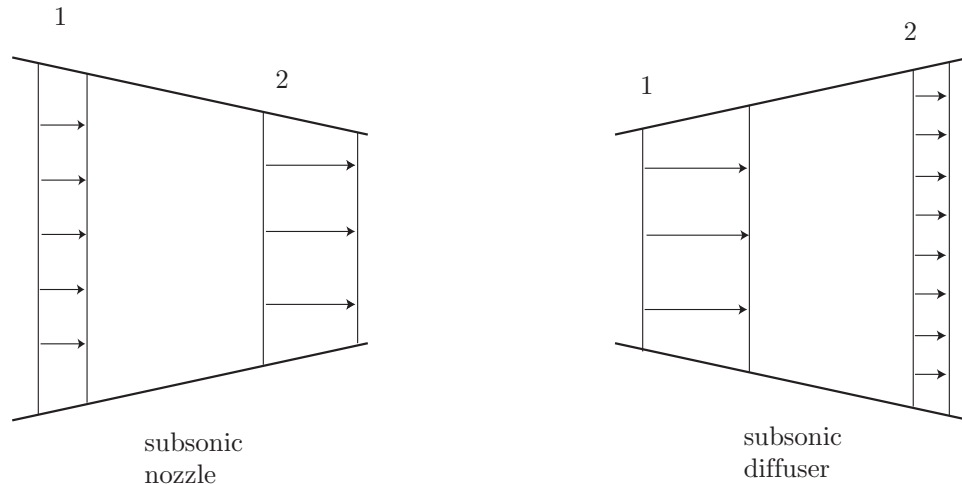

Figure 4.17: Sketch of subsonic nozzle and diffuser.

momentum, and energy principles, after detailed analysis, one finds the converse state of affairs for supersonic flow conditions. Supersonic nozzles have increasing area; supersonic diffusers have decreasing area. This is why in the design of rocket nozzles, the cross-sectional area broadens at the base. The broadening area induces a higher velocity, and induces a higher thrust for a supersonic rocket engine. A brief analysis of this will be given in Ch. 9.8.3.

We analyze nozzles and diffusers as follows. Mass conservation tells us

$$\underbrace{\frac{dm_{cv}}{dt}}_{=0} = \dot{m}_1 - \dot{m}_2, \quad (4.263)$$

$$\dot{m}_1 = \dot{m}_2 = \dot{m}. \quad (4.264)$$

Energy conservation tells us

$$\underbrace{\frac{dE_{cv}}{dt}}_{=0} = \dot{Q}_{cv} - \underbrace{\dot{W}_{cv}}_{=0} + \dot{m}_1 \left(h_1 + \frac{v_1^2}{2} + gz_1 \right) - \dot{m}_2 \left(h_2 + \frac{v_2^2}{2} + gz_2 \right), \quad (4.265)$$

$$0 = \dot{Q}_{cv} + \dot{m} \left(h_1 - h_2 + \frac{v_1^2}{2} - \frac{v_2^2}{2} + \underbrace{gz_1 - gz_2}_{=0} \right), \quad (4.266)$$

$$0 = \frac{\dot{Q}_{cv}}{\dot{m}} + h_1 - h_2 + \frac{v_1^2}{2} - \frac{v_2^2}{2}. \quad (4.267)$$

If the nozzle or diffuser is also adiabatic, we get

$$h_1 + \frac{v_1^2}{2} = h_2 + \frac{v_2^2}{2}. \quad (4.268)$$

4.4.3 Turbine

A turbine is a device in which work is generated through expansion of a fluid as it passes through a fan-like device. The fluid interacts with the blades and turns the fan. Ultimately thermal and mechanical energy is transferred from the fluid into the rotational kinetic energy of the fan blades. A sketch of a turbine is given in Fig. 4.18. For a turbine, we typically

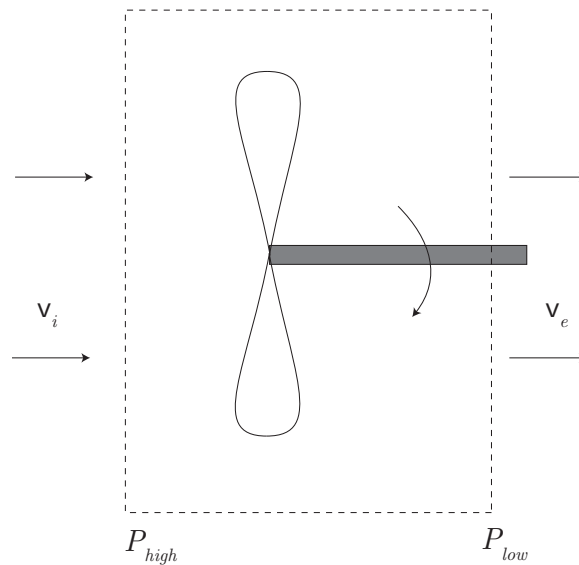

Figure 4.18: Highly simplified sketch of turbine.

neglect kinetic and potential energy changes of the fluid. We may or may not neglect heat

transfer. We also neglect any unsteady effects. Mass conservation tells us

$$\underbrace{\frac{dm_{cv}}{dt}}_{=0} = \dot{m}_1 - \dot{m}_2, \quad (4.269)$$

$$\dot{m}_1 = \dot{m}_2 = \dot{m}. \quad (4.270)$$

Energy conservation tells us

$$\underbrace{\frac{dE_{cv}}{dt}}_{=0} = \dot{Q}_{cv} - \dot{W}_{cv} + \dot{m}_1 \left(h_1 + \frac{v_1^2}{2} + gz_1 \right) - \dot{m}_2 \left(h_2 + \frac{v_2^2}{2} + gz_2 \right), \quad (4.271)$$

$$0 = \dot{Q}_{cv} - \dot{W}_{cv} + \dot{m} \left(h_1 - h_2 + \underbrace{\frac{v_1^2}{2} - \frac{v_2^2}{2}}_{=0} + \underbrace{gz_1 - gz_2}_{=0} \right), \quad (4.272)$$

$$0 = \dot{Q}_{cv} - \dot{W}_{cv} + \dot{m}(h_1 - h_2), \quad (4.273)$$

$$\dot{W}_{cv} = \dot{Q}_{cv} + \dot{m}(h_1 - h_2). \quad (4.274)$$

We often neglect \dot{Q}_{cv} to get

$$\boxed{\dot{W}_{cv} = \dot{m}(h_1 - h_2)}. \quad (4.275)$$

On a per mass basis, we can scale by \dot{m} to get

$$w = h_1 - h_2. \quad (4.276)$$

For turbines, $h_1 > h_2$, so we get $w > 0$. The device is doing work.

4.4.4 Pumps and compressors

The analysis for a pump or compressor is effectively identical to that for a turbine. However the device operates in an opposite sense. Mechanical energy from either rotating (like a compressor in a jet engine) or reciprocating machinery (like a piston-cylinder arrangement) is transferred to the working fluid, raising its energetic state. We typically neglect changes in kinetic and potential energy of the fluid and consider the device to be in a steady state. We sometimes neglect heat transfer to the device.

The analysis is as follows. Mass conservation tells us

$$\underbrace{\frac{dm_{cv}}{dt}}_{=0} = \dot{m}_1 - \dot{m}_2, \quad (4.277)$$

$$\dot{m}_1 = \dot{m}_2 = \dot{m}. \quad (4.278)$$

Energy conservation tells us

$$\underbrace{\frac{dE_{cv}}{dt}}_{=0} = \dot{Q}_{cv} - \dot{W}_{cv} + \dot{m}_1 \left(h_1 + \frac{v_1^2}{2} + gz_1 \right) - \dot{m}_2 \left(h_2 + \frac{v_2^2}{2} + gz_2 \right), \quad (4.279)$$

$$0 = \dot{Q}_{cv} - \dot{W}_{cv} + \dot{m} \left(h_1 - h_2 + \underbrace{\frac{v_1^2}{2} - \frac{v_2^2}{2}}_{=0} + \underbrace{gz_1 - gz_2}_{=0} \right), \quad (4.280)$$

$$0 = \dot{Q}_{cv} - \dot{W}_{cv} + \dot{m}(h_1 - h_2), \quad (4.281)$$

$$\dot{W}_{cv} = \dot{Q}_{cv} + \dot{m}(h_1 - h_2). \quad (4.282)$$

We often neglect \dot{Q}_{cv} to get

$$\boxed{\dot{W}_{cv} = \dot{m}(h_1 - h_2)}. \quad (4.283)$$

On a per mass basis, we can scale by \dot{m} to get

$$w = h_1 - h_2. \quad (4.284)$$

For pumps and compressors, $h_1 < h_2$, so we get $w < 0$. The device requires an input of work.

4.4.5 Heat exchanger

A heat exchanger is a device in which a working fluid trades its thermal energy with another working fluid. A sketch of a heat exchanger is given in Fig. 4.19. For heat exchangers, we

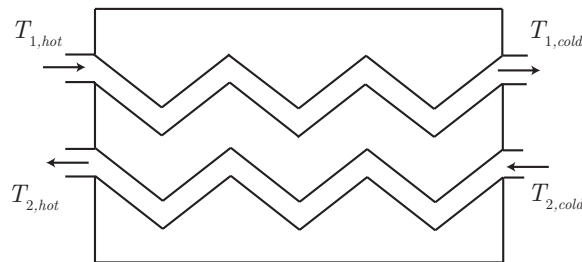

Figure 4.19: Sketch of counterflow heat exchanger.

typically neglect all work, as well as changes in kinetic and potential energy. Also

- there will be exchange of thermal energy between individual flow streams, but
- globally for the entire device, there will be no heat transfer with the environment.

Let us consider a counterflow heat exchanger. The mass balance for steady flow is trivial. The energy balance, neglecting changes in KE and PE states

$$\underbrace{\frac{dE_{cv}}{dt}}_{=0} = \underbrace{\dot{Q}_{cv}}_{=0} - \underbrace{\dot{W}_{cv}}_{=0} + \sum_i \dot{m}_i h_i - \sum_e \dot{m}_e h_e. \quad (4.285)$$

Applying this to the counterflow heat exchanger gives

$$\dot{m}_1 h_{1,hot} + \dot{m}_2 h_{2,cold} = \dot{m}_1 h_{1,cold} + \dot{m}_2 h_{2,hot}, \quad (4.286)$$

$$\dot{m}_1 (h_{1,hot} - h_{1,cold}) = \dot{m}_2 (h_{2,hot} - h_{2,cold}). \quad (4.287)$$

Example 4.11

Given an adiabatic air turbine with $\dot{m} = 1.5$ kg/s with the following inlet and exit conditions

- $P_i = 1000$ kPa,
- $T_i = 1200$ K,
- $P_e = 100$ kPa,
- $T_e = 700$ K,

calculate the work output of the turbine assuming i) CPIG, ii) CIIG, and neglecting changes in kinetic and potential energy. We have a simple sketch in Fig. 4.20.

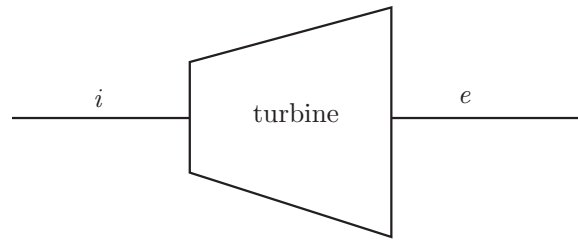

Figure 4.20: Sketch of turbine problem.

The first law for both CPIG and CIIG is the same. It is, after neglecting changes of kinetic and potential energy,

$$\underbrace{\frac{dE_{cv}}{dt}}_{=0} = \underbrace{\dot{Q}_{cv}}_{=0} - \dot{W}_{cv} + \dot{m}h_i - \dot{m}h_e. \quad (4.288)$$

Because this problem is adiabatic and steady, we get

$$\dot{W}_{cv} = \dot{m}(h_i - h_e). \quad (4.289)$$

Our estimate of the work output will depend on which caloric equation of state we choose.

- CPIG. For a CPIG, we have

$$h_i - h_e = c_P(T_i - T_e). \quad (4.290)$$

For ideal gases we have, $c_P - c_v = R$ and $k = c_P/c_v$. The second of these gives $c_v = c_P/k$. Substituting into the first gives

$$c_P - \frac{c_P}{k} = R, \quad (4.291)$$

$$c_P \left(1 - \frac{1}{k}\right) = R, \quad (4.292)$$

$$c_P \left(\frac{k-1}{k}\right) = R, \quad (4.293)$$

$$c_P = \frac{k}{k-1}R. \quad (4.294)$$

For diatomic gases at moderate temperatures, we have $k = 7/5$; thus,

$$c_P = \frac{k}{k-1}R = \frac{7/5}{7/5-1}R = \frac{7}{2}R, \quad c_v = \frac{1}{k-1}R = \frac{1}{7/5-1}R = \frac{5}{2}R. \quad (4.295)$$

So

$$c_P = \frac{7}{7/5-1} \left(0.287 \frac{\text{kJ}}{\text{kg K}}\right) = 1.0045 \frac{\text{kJ}}{\text{kg K}}, \quad (4.296)$$

$$c_v = \frac{1}{7/5-1} \left(0.287 \frac{\text{kJ}}{\text{kg K}}\right) = 0.7175 \frac{\text{kJ}}{\text{kg K}}. \quad (4.297)$$

Note these are the same values listed in Table A.5 of BS. So for the turbine work output, we get

$$\dot{W}_{cv} = \dot{m}c_P(T_i - T_e) = \left(1.5 \frac{\text{kg}}{\text{s}}\right) \left(1.0045 \frac{\text{kJ}}{\text{kg K}}\right) ((1200 \text{ K}) - (700 \text{ K})) = \boxed{753.375 \text{ kW}}. \quad (4.298)$$

- CIIG. For the CIIG, we have a few choices. We could use Table A.6 of BS to estimate c_P at an intermediate temperature, and then treat it as a constant. We could form the integral $\int_i^e c_P(T) dT$. Or we could use the ideal gas tables, Table A.7.1 of BS. Let us do the third method. At $T_i = 1200 \text{ K}$, we find

$$h_i = 1277.81 \frac{\text{kJ}}{\text{kg}}. \quad (4.299)$$

At $T_e = 700 \text{ K}$, we find

$$h_e = 713.56 \frac{\text{kJ}}{\text{kg}}. \quad (4.300)$$

So

$$\dot{W}_{cv} = \dot{m}(h_i - h_e) = \left(1.5 \frac{\text{kg}}{\text{s}}\right) \left(\left(1277.81 \frac{\text{kJ}}{\text{kg}}\right) - \left(713.56 \frac{\text{kJ}}{\text{kg}}\right)\right) = \boxed{846.375 \text{ kW}}. \quad (4.301)$$

The two methods yield similar results. Use of the more accurate CIIG reveals there is more useful work that can be expected when we take actual material behavior into account. This is because the high temperature gas has some extra energy stored in its vibrational modes that was unaccounted for by the CPIG model. Recall our CPIG model did account for rotational modes in taking $c_v = 5/2R$. But as can be seen from examining Fig. 3.33, for diatomic molecules in air, such as O_2 , $c_v/R > 5/2$ for our temperatures of $T \in [700 \text{ K}, 1200 \text{ K}]$. Presumably, molecular vibration is relevant at these elevated temperatures; in particular, the enhanced work predicted by the CIIG model is a manifestation of accounting for the additional energy available that was initially bound into vibrational modes at high temperature. The CIIG model properly accounts for this.

Example 4.12

Given a steam turbine with $\dot{m} = 1.5 \text{ kg/s}$, $\dot{Q}_{cv} = -8.5 \text{ kW}$ with the following inlet and exit conditions

- $P_i = 2 \text{ MPa}$,
- $T_i = 350 \text{ }^\circ\text{C}$,
- $v_i = 50 \frac{\text{m}}{\text{s}}$,
- $z_i = 6 \text{ m}$,
- $P_e = 0.1 \text{ MPa}$,
- $x_e = 1$,
- $v_e = 200 \frac{\text{m}}{\text{s}}$,
- $z_e = 3 \text{ m}$,

find the power output. The same simple sketch of Fig. 4.20 applies.

The first law states

$$\underbrace{\frac{dE_{cv}}{dt}}_{=0} = \dot{Q}_{cv} - \dot{W}_{cv} + \dot{m} \left(h_i + \frac{v_i^2}{2} + gz_i \right) - \dot{m} \left(h_e + \frac{v_e^2}{2} + gz_e \right), \quad (4.302)$$

$$\dot{W}_{cv} = \dot{Q}_{cv} + \dot{m} \left(h_i - h_e + \frac{1}{2}(v_i^2 - v_e^2) + g(z_i - z_e) \right). \quad (4.303)$$

From the steam tables, we learn

$$h_i = 3137 \frac{\text{kJ}}{\text{kg}}, \quad h_e = 2675.5 \frac{\text{kJ}}{\text{kg}}. \quad (4.304)$$

So

$$\begin{aligned} \dot{W}_{cv} &= (-8.5 \text{ kW}) + \left(1.5 \frac{\text{kg}}{\text{s}} \right) \left(\left(3137 \frac{\text{kJ}}{\text{kg}} \right) - \left(2675.5 \frac{\text{kJ}}{\text{kg}} \right) \right. \\ &\quad \left. + \frac{1}{2} \left(\frac{\text{kJ}}{1000 \text{ J}} \right) \left(\left(50 \frac{\text{m}}{\text{s}} \right)^2 - \left(200 \frac{\text{m}}{\text{s}} \right)^2 \right) + \frac{9.81 \frac{\text{m}}{\text{s}^2}}{1000 \frac{\text{J}}{\text{kJ}}} ((6 \text{ m}) - (3 \text{ m})) \right), \end{aligned} \quad (4.305)$$

$$= (-8.5 \text{ kW}) + \left(1.5 \frac{\text{kg}}{\text{s}} \right) \left(\underbrace{\left(461.6 \frac{\text{kJ}}{\text{kg}} \right)}_{=\Delta h} - \underbrace{\left(18.75 \frac{\text{kJ}}{\text{kg}} \right)}_{=\Delta KE} + \underbrace{\left(0.0294 \frac{\text{kJ}}{\text{kg}} \right)}_{=\Delta PE} \right), \quad (4.306)$$

$$= \boxed{655.7 \text{ kW.}} \quad (4.307)$$

Note

- The dominant term is the Δh term. Kinetic and potential energy changes, as well as heat transfer effects are small in comparison. This is typical for turbines.

- The factor of 1000 is necessary to give the units of specific kinetic and potential energy changes kJ/kg. Let us quickly check the units for kinetic energy, here without the factor of 1000:

$$\frac{\text{J}}{\text{kg}} = \frac{\text{N m}}{\text{kg}} = \frac{\text{kg m}^2}{\text{s}^2 \text{ kg}} = \frac{\text{m}^2}{\text{s}^2}. \quad (4.308)$$

4.5 Introduction to the Rankine cycle

Consider the

- **RANKINE CYCLE:** a thermodynamic cycle that forms the foundation for most steam power plants.

The cycle was studied analytically by Rankine,¹³ depicted in Fig. 4.21. We will consider



Figure 4.21: William John Macquorn Rankine (1820-1872), Scottish engineer who systematically studied and published discussion of steam power cycles. Image from https://en.wikipedia.org/wiki/William_John_Macquorn_Rankine.

additional nuances of the Rankine cycle in Ch. 8.1.

The key features of the Rankine cycle are

- 1 → 2: compression of a liquid by a pump,

¹³W. J. M. Rankine, 1859, *A Manual of the Steam Engine and Other Prime Movers*, Griffin, London.

- 2 \rightarrow 3: boiling of the liquid to form a vapor,
- 3 \rightarrow 4: expansion of the vapor through a turbine, and
- 4 \rightarrow 1: condensation of the vapor to liquid in a condenser.

A sketch of the Rankine cycle in the $P - v$ plane is given in Fig. 4.22. The Rankine

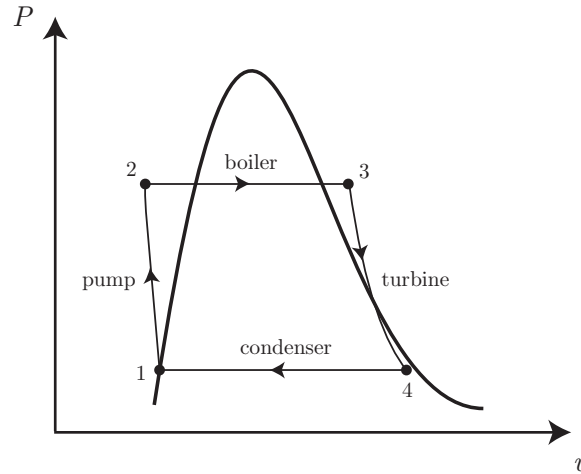

Figure 4.22: Sketch of Rankine cycle in the $P - v$ plane.

cycle forms the cornerstone of a wide variety of power generating devices in the world today. Whether the heat source comes from burning coal, natural gas, fuel oil, garbage, nuclear fission, solar energy, or some other source, it can always be used to boil water, that is the key feature of the Rankine cycle. Most modern power plants are considerably more complicated than the simple outline given here. Some are equipped to use a variety of fuels. Often coal burning components are used continuously for so-called base loads and are supplemented during peak consumption hours by natural gas. Some modern plants use natural gas for base loads. Some cycles are equipped for district heating and cooling, some for electric power generation, some for nautical propulsion.

Example 4.13

Consider the Rankine cycle sketched in Fig. 4.23 for generation of power. The conditions of the steam are indicated in Fig. 4.23.

The cycle includes some of the effect of losses; thus, it is not an ideal Rankine cycle. But it is close. Find, on a per unit mass basis,

- the heat transfer in the line between the boiler and the turbine,
- the turbine work,
- the heat transfer in the condenser, and

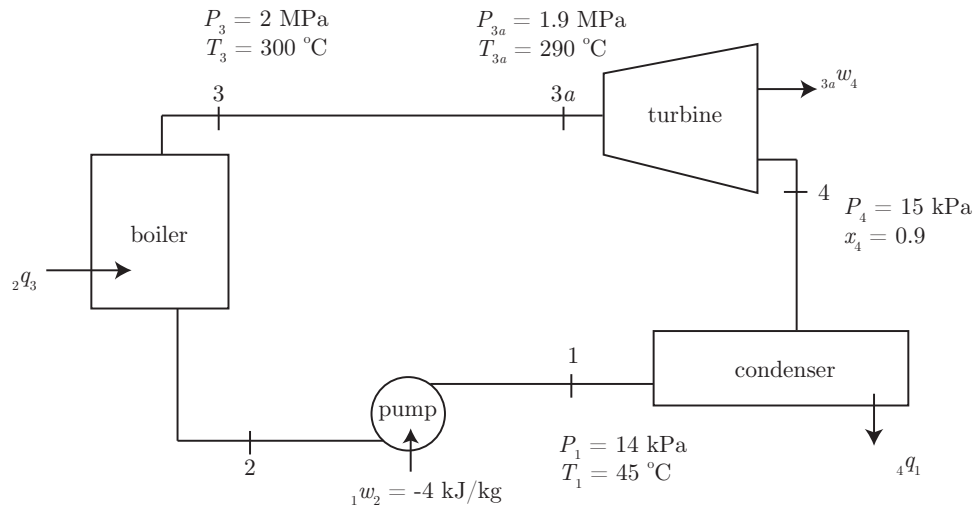

Figure 4.23: Sketch of steam power cycle, known as the Rankine cycle.

- the heat transfer in the boiler.

For illustration, Fig. 4.24 shows photographs of some elements of the University of Notre Dame Power Plant configured in a way that reflects the rudimentary Rankine cycle. The actual plant is more complex than indicated in Fig. 4.24. It contains additional elements for cooling, heating with gas and oil, and pollution removal. A full analysis is beyond the scope of these notes.

We use the steam tables for our equation of state. We can model this as a steady state system composed of devices with one inlet and one exit. We can neglect changes in KE and PE . For any such device, the mass flow rate \dot{m} is constant, and the energy balance gives

$$\underbrace{\frac{dE_{cv}}{dt}}_{=0} = \dot{Q}_{cv} - \dot{W}_{cv} + \dot{m}(h_i - h_e), \quad (4.309)$$

$$0 = q - w + h_i - h_e. \quad (4.310)$$

- *Work in pump.* Let us assume an ideal pump, that is adiabatic, ${}_1q_2 = 0$. Work is done by the pump on the fluid in compressing it. A pump restores the high pressure to the fluid to compensate for frictional losses.

$${}_1w_2 = h_i - h_e = h_1 - h_2. \quad (4.311)$$

We go to the tables and find $h_1 = 188.45$ kJ/kg. Now, we know ${}_1w_2 = -4$ kJ/kg, so this lets us calculate h_2 via

$$h_2 = h_1 - {}_1w_2 = \left(188.45 \frac{\text{kJ}}{\text{kg}}\right) - \left(-4 \frac{\text{kJ}}{\text{kg}}\right) = 192.45 \frac{\text{kJ}}{\text{kg}}. \quad (4.312)$$

Note:

- The pump work is relatively small, as will be seen by comparison to later calculations of work and heat transfers for other devices.
- *Heat transfer in boiler.* A boiler is an active device in which thermal energy of perhaps combustion or nuclear reaction is used to boil water. The tables tell us that $h_3 = 3023.5$ kJ/kg. There is no work

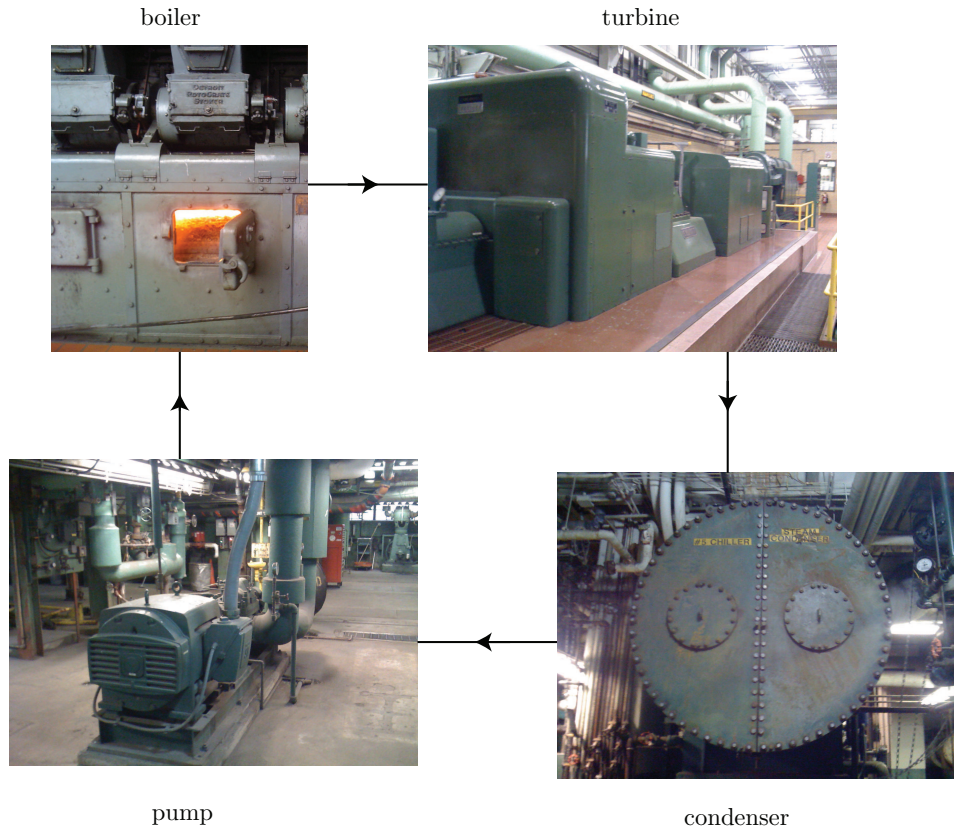

Figure 4.24: Elements of the University of Notre Dame Power Plant, configured in an oversimplified manner, 14 June 2010. At this time, the energy source was coal combustion, which is no longer the case.

in a boiler, so ${}_2w_3 = 0$, and the first law becomes

$${}_2q_3 = h_e - h_i = h_3 - h_2, \quad (4.313)$$

$$= \left(3023.5 \frac{\text{kJ}}{\text{kg}} \right) - \left(192.45 \frac{\text{kJ}}{\text{kg}} \right) = \boxed{2831.1 \frac{\text{kJ}}{\text{kg}}}. \quad (4.314)$$

Note

- The heat transfer to the boiler, ${}_2q_3 > 0$, so the thermal energy is entering the device.
- *Heat transfer in line between boiler and turbine.* For the flow in the pipe, there is no external shaft work, so ${}_3w_{3a} = 0$, and thus

$${}_3q_{3a} = h_e - h_i = h_{3a} - h_3. \quad (4.315)$$

From double interpolation of the steam tables, $h_{3a} = 3002.5 \text{ kJ/kg}$, so

$${}_3q_{3a} = \left(3002.5 \frac{\text{kJ}}{\text{kg}} \right) - \left(3023.5 \frac{\text{kJ}}{\text{kg}} \right) = \boxed{-21 \frac{\text{kJ}}{\text{kg}}}. \quad (4.316)$$

- Because the thermal energy leaves the pipe, ${}_3q_{3a} < 0$. In general we will find that q will be path-dependent. For this type of analysis, it reduces to differences in the end states.

- Note that P drops because of friction in the pipes.
 - Note that T drops because of heat transfer to the surroundings.
 - Most importantly, note that we easily determined a quantity of global importance with data that was easily measured at the inlet and exit of the pipe. We did not need to consider the detailed fluid and thermal fields within the pipe.
- *Turbine work.* We assume an ideal turbine, which is adiabatic, ${}_3q_4 = 0$, so

$${}_3w_4 = h_i - h_e = h_{3a} - h_4. \quad (4.317)$$

Now, we know h_{3a} already. For h_4 , we have

$$h_4 = h_f + x_4 h_{fg}, \quad \text{at } P_4 = 15 \text{ kPa}, \quad (4.318)$$

$$= \left(225.94 \frac{\text{kJ}}{\text{kg}} \right) + (0.9) \left(2373.1 \frac{\text{kJ}}{\text{kg}} \right), \quad (4.319)$$

$$= \boxed{2361.7 \frac{\text{kJ}}{\text{kg}}}. \quad (4.320)$$

Thus,

$${}_3w_4 = \left(3002.5 \frac{\text{kJ}}{\text{kg}} \right) - \left(2361.7 \frac{\text{kJ}}{\text{kg}} \right) = 640.8 \frac{\text{kJ}}{\text{kg}}. \quad (4.321)$$

Note

- the pressure P drops as the steam expands through the turbine,
 - the work ${}_3w_4 > 0$, that indicates the turbine is doing work, and
 - the function of a turbine is precisely that: to do work.
- *Heat transfer in condenser.* A condenser is just a place for steam to convert to liquid water. It is a passive device. So ${}_4w_1 = 0$. The first law reduces to

$${}_4q_1 = h_e - h_i = h_1 - h_4. \quad (4.322)$$

We know h_4 . And h_1 is a compressed liquid state. Let us approximate h_1 using the saturated liquid value at $T = 45 \text{ }^\circ\text{C}$; thus, $h_1 = 188.45 \text{ kJ/kg}$. So

$${}_4q_1 = \left(188.45 \frac{\text{kJ}}{\text{kg}} \right) - \left(2361.7 \frac{\text{kJ}}{\text{kg}} \right) = \boxed{-2173.25 \frac{\text{kJ}}{\text{kg}}}. \quad (4.323)$$

Note:

- the heat transfer ${}_4q_1 < 0$ because thermal energy leaves the condenser to the surroundings. This is why cooling lakes near power plants are warmer than they otherwise would be.

This problem is an example of a *thermodynamic cycle*. This particular cycle is important because it is the foundation of most electric power generation in the world, as well as many other applications. We can introduce the concept of a *cycle thermal efficiency*, η as the ratio of what we want to what we pay for. Here, we want net work, that is the difference of the turbine work and the pump work, and we pay

| Process | $\Delta h \left(\frac{\text{kJ}}{\text{kg}} \right)$ | $q \left(\frac{\text{kJ}}{\text{kg}} \right)$ | $w \left(\frac{\text{kJ}}{\text{kg}} \right)$ |
|--------------------|---|--|--|
| 1 \rightarrow 2 | 4 | 0 | -4 |
| 2 \rightarrow 3 | 2831.1 | 2831.1 | 0 |
| 3 \rightarrow 3a | -21 | -21 | 0 |
| 3a \rightarrow 4 | -640.8 | 0 | 640.8 |
| 4 \rightarrow 1 | -2173.25 | -2173.25 | 0 |
| Total | 0 | 636.8 | 636.8 |

Table 4.1: First law analysis summary for our non-ideal Rankine cycle.

for the heat transfer into the boiler. Mathematically, we have

$$\eta = \frac{\text{what we want}}{\text{what we pay for}}, \quad (4.324)$$

$$= \frac{w_{\text{cycle}}}{q_{\text{in}}}, \quad (4.325)$$

$$= \frac{w_{\text{turbine}} + w_{\text{pump}}}{q_{\text{boiler}}}, \quad (4.326)$$

$$= \frac{3aw_4 + 1w_2}{2q_3}, \quad (4.327)$$

$$= \frac{\left(640.8 \frac{\text{kJ}}{\text{kg}} \right) + \left(-4 \frac{\text{kJ}}{\text{kg}} \right)}{2831.1 \frac{\text{kJ}}{\text{kg}}}, \quad (4.328)$$

$$= 0.225. \quad (4.329)$$

This is a low efficiency by modern standards. Later we shall use the second law of thermodynamics to calculate the peak efficiency of a steam power plant. That analysis will reveal that the peak efficiency for this plant is $\eta = 0.445$.

In a spirit similar to that of double-entry accounting, we summarize the key energy balances in Table 4.1. Note there is some small round-off error due mainly due to significant digits and interpolation that has been ignored in Table 4.1. Each row must maintain the control volume balance $\Delta h = q - w$. Each column must add to form its total. Because h is a state property, the net Δh for the cycle must be zero. And to satisfy the first law for the cycle, the total q must equal the total w .

There is another useful way to formulate the thermal efficiency. We can begin with Eq. (4.327) and say

$$\eta = \frac{3aw_4 + 1w_2}{2q_3}. \quad (4.330)$$

Using Eqs. (4.311,4.313), we can reform Eq. (4.330) as

$$\eta = \frac{(h_{3a} - h_4) + (h_1 - h_2)}{h_3 - h_2}, \quad (4.331)$$

$$= \frac{h_{3a} - h_3 + h_3 - h_4 + h_1 - h_2}{h_3 - h_2}, \quad (4.332)$$

$$= \frac{(h_{3a} - h_3) + (h_3 - h_2) + (h_1 - h_4)}{h_3 - h_2}, \quad (4.333)$$

$$= 1 - \frac{(h_3 - h_{3a}) + (h_4 - h_1)}{h_3 - h_2}. \quad (4.334)$$

And with the net heat entering as $q_{in} = h_3 - h_2$ and the net heat loss as $q_{out} = (h_3 - h_{3a}) + (h_4 - h_1)$, we can express Eq. (4.334) as

$$\eta = 1 - \frac{q_{out}}{q_{in}} = \frac{q_{in} - q_{out}}{q_{in}} = \frac{w_{cycle}}{q_{in}}. \quad (4.335)$$

The local steam power plant at the University of Notre Dame runs on a variant of the Rankine cycle. This particular power plant relies on a local source, St. Joseph's Lake, for its cooling water. On a cold winter day, the effect of the power plant on St. Joseph's Lake, relative to the nearby St. Mary's Lake, that has no connection to the power plant, is dramatic. Fig. 4.25 shows the two lakes on the same day. The power plant also generates steam for heating of the buildings on campus that requires



Figure 4.25: St. Joseph's Lake (left) and St. Mary's Lake (right) on the University of Notre Dame campus, 14 February 2010, demonstrating the effect of exchanging heat with the condenser of the Notre Dame power plant near St. Joseph's Lake.

many underground steam lines. The effect of heat loss is the lines is obvious on many winter days on the Notre Dame campus as is evident from Fig. 4.26.



Figure 4.26: Zones of melted snow in regions near underground steam lines on the University of Notre Dame campus, 14 February 2010.

4.6 Preview: equations of continuum mechanics

This course focuses on mass and energy conservation coupled with equations of state for systems that are well modeled as quasi-equilibrium processes. We can do many important problems with these tools. However, there are many problems that we cannot do with these tools, e.g. problems with coupled time- and space-dependency, or problems with detailed material motion.

Let us, as a preview for future courses, write various related sets of partial differential equations that can couple equilibrium thermodynamics with mechanics.

4.6.1 Full set

We first give a summary of a reasonably complete and general set of equations for a continuum material. One way to write these equations is as follows:

$$\frac{\partial \rho}{\partial t} + \nabla \cdot (\rho \mathbf{v}) = 0 \quad \text{mass,} \quad (4.336)$$

$$\frac{\partial}{\partial t}(\rho \mathbf{v}) + \nabla \cdot (\rho \mathbf{v} \mathbf{v}) = \rho \mathbf{g} - \nabla P + \nabla \cdot \boldsymbol{\tau},$$

linear momenta, (4.337)

$$\boldsymbol{\tau}^T = \boldsymbol{\tau}, \quad \text{angular momenta,} \quad (4.338)$$

$$\frac{\partial}{\partial t} \left(\rho \left(u + \frac{1}{2} \mathbf{v} \cdot \mathbf{v} \right) \right) + \nabla \cdot \left(\rho \mathbf{v} \left(u + \frac{1}{2} \mathbf{v} \cdot \mathbf{v} \right) \right) = -\nabla \cdot \mathbf{q} - \nabla \cdot (P \mathbf{v}) + \nabla \cdot (\boldsymbol{\tau} \cdot \mathbf{v})$$

$+ \rho \mathbf{v} \cdot \mathbf{g}, \quad \text{energy.} \quad (4.339)$

Equations (4.336-4.339) are the axioms of mass conservation, linear momenta conservation, angular momenta conservation, and energy conservation, respectively. They are valid for any pure material, be it solid, liquid, or gas, as long as we are at velocities small relative to the velocity of light. New variables here include the deviatoric stress tensor $\boldsymbol{\tau}$, and the heat flux vector \mathbf{q} . The vector \mathbf{g} is the constant gravitational acceleration. It is easily modified for variable gravitational acceleration.

The conservation axioms are necessary but insufficient to determine all flow variables. They must be supplemented by *constitutive relations*. Constitutive relations specify the actual material. A general set is given here.

$$P = P(\rho, T), \quad \text{thermal EOS,} \quad (4.340)$$

$$u = u(\rho, T), \quad \text{caloric EOS,} \quad (4.341)$$

$$\mathbf{q} = \mathbf{q}(T, \nabla T, \dots), \quad \text{heat flux,} \quad (4.342)$$

$$\boldsymbol{\tau} = \boldsymbol{\tau}(T, \nabla \mathbf{v}, \nabla \mathbf{x}, \dots), \quad \text{stress.} \quad (4.343)$$

Equation (4.340) is a thermal equation of state. An example is the ideal gas law $P = \rho RT$. Equation (4.341) is a caloric equation of state. An example is a calorically perfect ideal gas, $u = c_v(T - T_o) + u_o$. Equation (4.342) is a relation between the heat flux vector and

other state variables. An example is Fourier's law, $\mathbf{q} = -k\nabla T$. Equation (4.343) is a relation between the deviatoric stress and a variety of variables. For example, a Newtonian fluid obeying Stokes' assumption has $\boldsymbol{\tau} = \mu((\nabla\mathbf{v} + (\nabla\mathbf{v})^T) - (1/3)(\nabla \cdot \mathbf{v})\mathbf{I})$. This relates stress to strain rate. On the other hand, the stress in a solid would be related to the strain, instead of the strain rate.

4.6.2 Static solids equations

For a static solid, we take $\mathbf{v} = \mathbf{0}$ and the density constant. The mass equation becomes irrelevant, as does the angular momenta equation. The linear momenta equation reduces to a force balance, because inertia is zero. We take the total stress tensor $\boldsymbol{\sigma} = \boldsymbol{\tau} - P\mathbf{I}$, where \mathbf{I} is the identity matrix.

$$\nabla \cdot \boldsymbol{\sigma} = -\rho\mathbf{g}, \quad \text{linear momenta.} \quad (4.344)$$

$$\boldsymbol{\sigma} = \frac{E}{1+\nu} \left(\mathbf{e} + \frac{\nu}{1-2\nu} \text{tr}(\mathbf{e})\mathbf{I} \right), \quad \text{stress-strain relation.} \quad (4.345)$$

Here, E is the modulus of elasticity, ν is Poisson's ratio ($-1 \leq \nu \leq 1/2$), and \mathbf{e} is the strain.

4.6.3 Incompressible fluid mechanics equations

In the discipline of incompressible fluid mechanics, we typically take ρ to be a constant along a given fluid particle pathline, consider fluid properties such as viscosity and conductivity to be constant, and reduce our equations to the following set

$$\nabla \cdot \mathbf{v} = 0, \quad \text{mass,} \quad (4.346)$$

$$\rho \left(\frac{\partial \mathbf{v}}{\partial t} + \mathbf{v} \cdot \nabla \mathbf{v} \right) = \rho\mathbf{g} - \nabla P + \mu \nabla^2 \mathbf{v}, \quad \text{linear momenta,} \quad (4.347)$$

$$\boldsymbol{\tau}^T = \boldsymbol{\tau}, \quad \text{angular momenta,} \quad (4.348)$$

$$\rho c_P \left(\frac{\partial T}{\partial t} + \mathbf{v} \cdot \nabla T \right) = \left(\frac{\partial P}{\partial t} + \mathbf{v} \cdot \nabla P \right) + k \nabla^2 T + 2\mu \nabla \mathbf{v} : \nabla \mathbf{v}, \quad \text{energy,} \quad (4.349)$$

$$\boldsymbol{\tau} = \mu(\nabla\mathbf{v} + (\nabla\mathbf{v})^T), \quad \text{stress-strain rate,} \quad (4.350)$$

$$\mathbf{q} = -k\nabla T, \quad \text{Fourier's law} \quad (4.351)$$

The thermodynamic state equations are not particularly important here. Moreover, the mass and linear momenta equations form an independent set. The energy equation is coupled to mass and momenta equations because of the velocity vector.

4.6.4 Compressible fluid mechanics equations

In compressible fluid mechanics, we account for density changes and thermodynamics, but usually neglect gravity, viscosity and heat conduction. Our equations reduce to, for a CPIG,

$$\left(\frac{\partial \rho}{\partial t} + \mathbf{v} \cdot \nabla \rho\right) + \rho \nabla \cdot \mathbf{v} = 0, \quad \text{mass}, \quad (4.352)$$

$$\rho \left(\frac{\partial \mathbf{v}}{\partial t} + \mathbf{v} \cdot \nabla \mathbf{v}\right) = -\nabla P, \quad \text{linear momenta}, \quad (4.353)$$

$$\left(\frac{\partial u}{\partial t} + \mathbf{v} \cdot \nabla u\right) = -P \left(\frac{\partial v}{\partial t} + \mathbf{v} \cdot \nabla v\right), \quad \text{energy}, \quad (4.354)$$

$$P = \rho RT, \quad \text{thermal state}, \quad (4.355)$$

$$u = c_v T + u_o, \quad \text{caloric state}. \quad (4.356)$$

Notice the energy equation is simply the familiar $du/dt = -Pdv/dt$, when d/dt is interpreted as the material derivative $\partial/\partial t + \mathbf{v} \cdot \nabla$. Also note that the mass equation is $d\rho/dt = -\rho \nabla \cdot \mathbf{v}$. Thus the incompressibility condition $\nabla \cdot \mathbf{v} = 0$ implies $d\rho/dt = 0$.

4.6.5 Heat transfer in incompressible static solids

For heat transfer in static solids, we require $\mathbf{v} = \mathbf{0}$. Moreover, there is no work. We take a calorically perfect solid with constant thermal conductivity \mathbf{k} that obeys Fourier's law $\mathbf{q} = -\mathbf{k} \nabla T$ and get the first law of thermodynamics to reduce to the simple scalar equation known to Fourier in the early nineteenth century:

$$\rho c \frac{\partial T}{\partial t} = \mathbf{k} \nabla^2 T, \quad \text{energy}. \quad (4.357)$$

Chapter 5

The second law of thermodynamics

Read BS, Chapter 5

Conservation of mass and energy are fine concepts that allow us to quantify and predict well many phenomena that are observed in nature. And if a phenomenon can be repeated, it becomes subject to prediction, and can be thought of as a science.

However, *conservation of mass and energy, by themselves, admit as possibilities phenomena that are not observed in nature!* For instance consider an isolated system composed of two equal masses of liquid water. See Fig. 5.1. The first is at $T_A = 310$ K, the second is at

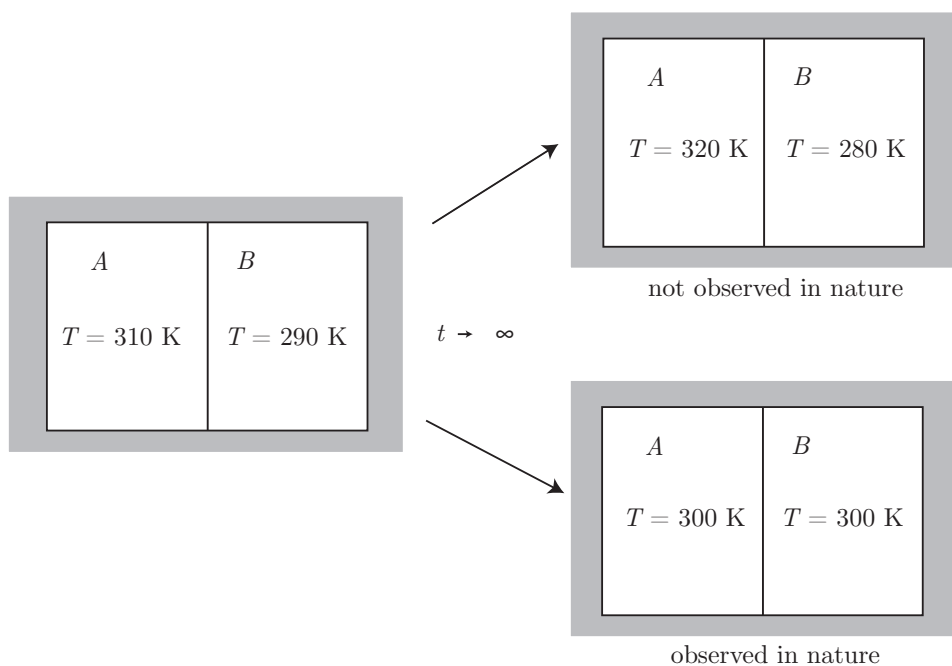

Figure 5.1: Sketch of two scenarios, both of which satisfy mass and energy conservation.

$T_B = 290$ K. A long time elapses. Because the combined system is isolated, there are no

external heat or work exchanges with the environment. But we will allow heat exchanges between mass A and mass B . Consider two possibilities, both admitted by mass and energy conservation, as $t \rightarrow \infty$:

- $T_A \rightarrow 320$ K, $T_B \rightarrow 280$ K. The thermal energy that is gained by A is lost by B , such that the net energy is conserved and the first law is satisfied. *This is never observed in nature.*
- $T_A \rightarrow 300$ K, $T_B \rightarrow 300$ K. The thermal energy that is lost by A is gained by B , so once again the first law is satisfied. *This is always observed in nature.*

So mass conservation and the first law of thermodynamics, both of which speak to this *gedankenexperiment*, are insufficient to guarantee that we will predict what is observed in nature. We need another axiom!

In a similar way, there are a variety of phenomena that may satisfy mass and energy conservation, but are not observed in nature. Some include

- water running uphill without an external assist,
- CO_2 and H_2O reacting spontaneously to form CH_4 and O_2 , and
- air separating into its constituents spontaneously.

5.1 Statements of the second law

The *second law of thermodynamics* is an attempt to provide a single all-encompassing statement that expands our thermodynamic theory so as to predict the just-described behavior. Though our statement of the second law will be simple enough, it will be obtuse and sometimes difficult to reconcile with nature. It is also a profound concept that has wide ranging ramifications. Its origins are firmly rooted in the engineering sciences, as it was motivated by optimization of steam engines. However, it has found applications in many realms of physics, chemistry, ecology, economics, computer science, and other fields.

In his influential essay contrasting scientific and humanistic cultures, C. P. Snow¹ sees understanding of the second law as an indicator of scientific literacy and goes on to chide his humanist colleagues:

A good many times I have been present at gatherings of people who, by the standards of the traditional culture, are thought highly educated and who have with considerable gusto been expressing their incredulity at the illiteracy of scientists. Once or twice I have been provoked and have asked the company how many of them could describe the Second Law of Thermodynamics, the law of entropy. The response was cold: it was also negative. Yet I was asking something which is

¹C. P. Snow, 1959, *The Two Cultures*, Cambridge U. Press, Cambridge (reprinted 1998).

about the scientific equivalent of: ‘Have you read a work of Shakespeare’s?’ I now believe that if I had asked an even simpler question —such as, What do you mean by mass, or acceleration, which is the scientific equivalent of saying, ‘Can you read?’ —not more than one in ten of the highly educated would have felt that I was speaking the same language. So the great edifice of modern physics goes up, and the majority of the cleverest people in the western world have about as much insight into it as their Neolithic ancestors would have had.

Let us summarize some more reasons for studying the second law:

- It predicts the direction in time of processes.
- It aids in determining equilibrium conditions.
- It allows one to determine peak performance of practical devices.
- It enables one to frame analysis of the factors that inhibit the realization of peak performance.
- It allows a rational definition of the absolute temperature scale.
- It has implications beyond engineering in physics, philosophy, economics, computer science, etc.

5.1.1 Entropy-based statement

There are many ways to state the second law of thermodynamics. One statement is as follows:

- **SECOND LAW OF THERMODYNAMICS:** The entropy of an isolated system can never decrease with time.

This definition begs the question, what is entropy? A formal definition will be deferred to the next chapter. Let us loosely define it here as a measure of the so-called randomness (or disorder) of a system, with high randomness corresponding to high entropy. Low randomness or low disorder often corresponds to low entropy.

Interpreted in another way, structure or order requires energy input to be realized, while over time, without continued maintenance, structure and order decay. The formulation of the second law we adopt will be robust enough to prevent us from predicting water to run uphill, methane to spontaneously form from carbon dioxide and water, or air to separate into its constituents. It will also be seen to be an important principle for predicting the optimal behavior of a wide variety of engineering devices.

All that said, it should be noted that the equivalence of entropy with disorder, while useful and common, is likely not universal. Certainly Wright² characterizes it as “a highly

²P. G. Wright, 1970, “Entropy and disorder,” *Contemporary Physics*, 11(6): 581-588.

contentious opinion” and discusses counter-examples, especially as related to molecular level phenomena. Wright’s arguments are reinforced by Styer,³ who concludes that the notion of “entropy as disorder” be used only in conjunction with the notion of “entropy as freedom.” Freedom here is to be interpreted as the ability to acquire a variety of states: if only one state is available, freedom is severely restricted, and entropy is low; if many states are available, freedom is widespread, and entropy is high. Both terms, “disorder” and “freedom” are shown by Styer to have alternate interpretations that render both imperfect metaphors for entropy.

5.1.2 Clausius statement

Clausius, the German mathematical physicist who probably did the most to cast thermodynamics on a scientific basis, gives a more precise statement of the second law:

- SECOND LAW OF THERMODYNAMICS: “Heat cannot, of itself, pass from a colder to a hotter body.”⁴

The original German version appeared earlier⁵ and is reproduced in Fig. 5.2.

Dieser Grundsatz, auf welchem die ganze folgende Entwicklung beruht, lautet: *es kann nie Wärme aus einem kälteren in einen wärmeren Körper übergehen, wenn nicht gleichzeitig eine andere damit zusammenhängende Änderung eintritt. Er wird durch Alles, was wir über den Wärme-*

Figure 5.2: Image of the original 1854 appearance of the Clausius form of the second law.

The Clausius formulation of the second law is easy to understand in engineering terms and is illustrated schematically in Fig. 5.3. Note that air conditioners move heat from cold regions to hot regions, but that work input is required.

5.1.3 Kelvin-Planck statement

Another statement of the second law is inspired by statements of the nineteenth century scientists, Kelvin and Planck, depicted in Fig. 5.4. The so-called Kelvin-Planck statement, a modern rendition of earlier statements, is often given as

- SECOND LAW OF THERMODYNAMICS: It is impossible for any system to operate in a thermodynamic cycle and deliver a net amount of work to its surroundings while receiving an energy transfer by heat from a single thermal reservoir.

³D. F. Styer, 2000, “Insight into entropy,” *American Journal of Physics*, 68(12): 1090-1096.

⁴R. Clausius, 1879, *The Mechanical Theory of Heat*, Macmillan, London, p. 78.

⁵R. Clausius, 1854, “Ueber eine veränderte Form des zweiten Hauptsatzes der mechanischen Wärmetheorie,” *Annalen der Physik und Chemie*, 169(12): 481-506.

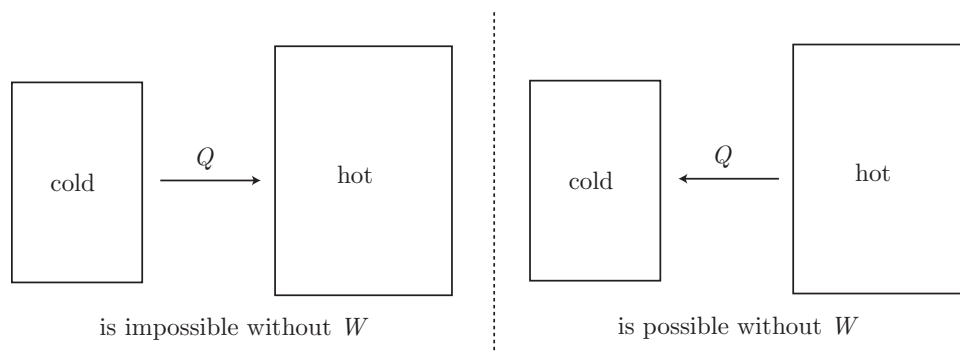

Figure 5.3: Schematic of the Clausius statement of the second law of thermodynamics.

Thomson’s original 1851 statement⁶ is somewhat different. Planck’s 1897 statement⁷ is closer. Both are reproduced in Fig. 5.5.

The Kelvin-Planck formulation of the second law is easy to understand in engineering terms and is illustrated schematically in Fig. 5.6. For the schematic of Fig. 5.6, the first law, neglecting changes in kinetic and potential energy, states that

$$U_2 - U_1 = Q - W. \quad (5.1)$$

But we have specified that the process is a cycle, so $U_1 = U_2$, and thus the first law holds

$$Q = W. \quad (5.2)$$

Now, the second law, for this scenario, holds that positive Q cannot be delivered, that gives, for an engine in contact with a *single* thermal reservoir,

$$Q \leq 0, \quad W \leq 0. \quad (5.3)$$

In informal language, the Kelvin-Planck statement says

- you can turn all the work into heat, but
- you cannot turn all the heat into work.

5.1.4 Carathéodory statement

Another form of the second law was given by the mathematician and advocate for the axiomatic approach to thermodynamics, Carathéodory, depicted in Fig. 5.7. The Carathéodory statement⁸ is

⁶W. Thomson (later Lord Kelvin), 1851, “On the dynamical theory of heat, with numerical results deduced from Mr. Joule’s equivalent of a thermal unit, and M. Regnault’s observations on steam,” *Transactions of the Royal Society of Edinburgh*, 20: 261-268; 289-298.

⁷M. Planck, 1897, *Vorlesungen über Thermodynamik*, Walter de Gruyter, Berlin; reprinted in English translation as *Treatise on Thermodynamics*, Dover, New York, p. 89.

⁸C. Carathéodory, 1909, “Untersuchungen über die Grundlagen der Thermodynamik,” *Mathematische Annalen*, 67: 355-386.

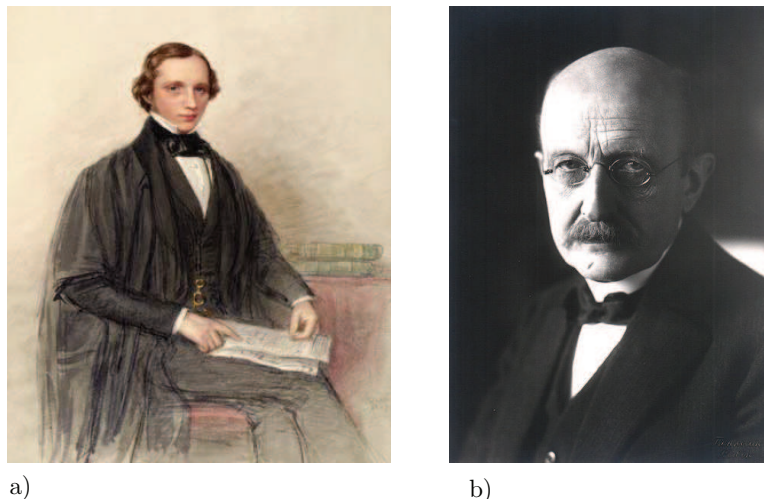

Figure 5.4: a) William Thomson (Lord Kelvin) (1824-1907), Ulster-born Scottish scientist who had profound impact on nineteenth century science including thermodynamics. Image from <http://mathshistory.st-andrews.ac.uk/Biographies/Thomson.html>, b) Max Karl Ernst Ludwig Planck (1858-1947), German physicist. Image from [https://commons.wikimedia.org/wiki/File:Max_Planck_\(1858-1947\).jpg](https://commons.wikimedia.org/wiki/File:Max_Planck_(1858-1947).jpg).

It is impossible, by means of inanimate material agency, to derive mechanical effect from any portion of matter by cooling it below the temperature of the coldest of the surrounding objects.*

a) Kelvin

*It is impossible to construct an engine which will work in a complete cycle, and produce no effect except the raising of a weight and the cooling of a heat-reservoir.**

b) Planck

Figure 5.5: Images of a) Thomson's 1851 and b) Planck's 1897 statements of the second law of thermodynamics.

- **SECOND LAW OF THERMODYNAMICS:** In the neighborhood of any equilibrium state of a thermodynamic system, there are equilibrium states that are adiabatically inaccessible.

Demonstration of its equivalence to other statements is not straightforward, and we shall not consider it in any further detail in these notes; nevertheless, the notions embodied in this statement as well as the school of thought in thermodynamics that has grown around the work of its author has benefits associated with casting thermodynamics in the context of more general mathematical ideas, thus making results from modern mathematics more easily applicable to thermodynamics. The work of Carathéodory is often dismissed as somehow too mathematical. Indeed, his approach to thermodynamics in general requires a mathematical sophistication beyond that needed to understand the more common Clausius or Kelvin-Planck formulations. The interested reader can consult a relevant discussion.⁹

⁹M. W. Zemansky, 1966, "Kelvin and Caratheodory—a reconciliation," *American Journal of Physics*, 34(10): 914-920.

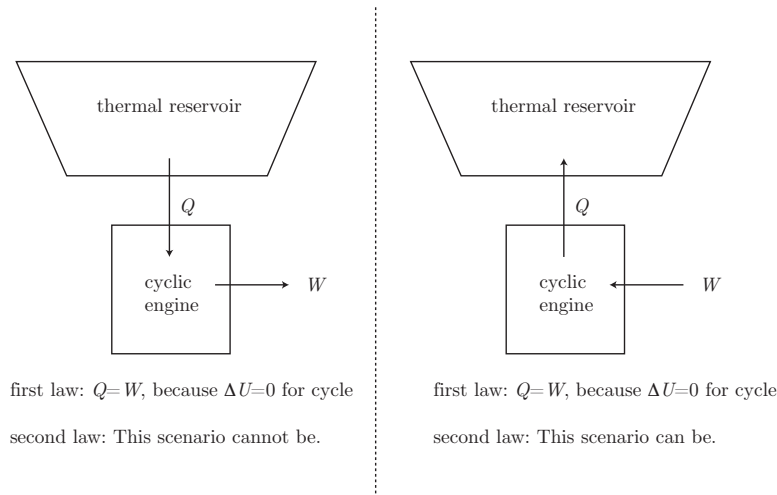

Figure 5.6: Schematic of the Kelvin-Planck statement of the second law of thermodynamics.

5.1.5 Judeo-Christian statement

One finds in Genesis 3:19 the admonition given by the Catholic church in its Ash Wednesday services,

- MODULATED SECOND LAW OF THERMODYNAMICS: Remember man that thou art dust, and unto dust thou shalt return.

5.1.6 Historian-inspired statement

The great American historian and generalist, Henry Brooks Adams (1838-1918) grandson and great-grandson of American presidents, wrote a detailed and entertaining essay on the second law. Among his many comments is included¹⁰

- ADAMS' SECOND LAW OF THERMODYNAMICS: "...but to the vulgar and ignorant historian it meant only that the ash-heap was constantly increasing in size."

5.1.7 Literature-inspired statement

Though he probably did not intend it for engineering, the Nobel literature laureate Chinua Achebe's most famous novel has a title that also serves as a rough-and-ready statement of the second law:

- INFORMAL SECOND LAW OF THERMODYNAMICS: Things fall apart.

The title of the novel is drawn from a line in Nobel literature laureate William Butler Yeats' apocalyptic 1921 poem, *The Second Coming*.

¹⁰H. B. Adams, 1910, *A Letter to American Teachers of History*, J. H. Furst, Washington.



Figure 5.7: Constantin Carathéodory (1873-1950), Greek mathematician. Image from https://en.wikipedia.org/wiki/Constantin_Caratheodory.

5.1.8 Food service-inspired statement

- SECOND LAW OF THERMODYNAMICS, SPECIAL CASE: Untended food rots.

5.2 Reversible and irreversible processes

We shall find it useful to have in hand definitions for so-called reversible and irreversible processes. Let us take

- REVERSIBLE PROCESS: A process in which it is possible to return both the system and surroundings to their original states.
- IRREVERSIBLE PROCESS: A process in which it is impossible to return both the system and surroundings to their original states.

Now, it may be possible to restore the system to its original state but not the surroundings (or the surroundings to its original state but not the system). Such a process is irreversible.

We shall often study reversible processes as they represent an ideal of the most we can ever hope to achieve. Some common engineering idealizations of reversible processes include

- frictionless motion,
- ideal inviscid flow of a fluid over an airfoil.

Now, everything in the real world deviates from the ideal. In flow over a wing, friction in the form of viscosity causes local irreversible heating of the air near the wing and the wing itself. Often in the real world these irreversibilities are confined to small regions and often do not largely affect the motion of the body.

If the world in which we live were reversible, we would realize some benefits, but ultimately life would be impossible. In a reversible world

- Pendulum clocks would never need to be rewound.
- Electricity would flow without generating heat; thus, computer fans would be unnecessary, among other things, but
- We would not be able to walk!

5.3 Analysis of Carnot heat engines

Here, we will present what amounts to a version of the discussion of the 1850s inspired by the original work of Carnot¹¹ depicted along with his writings in Fig. 5.8, for heat engines.

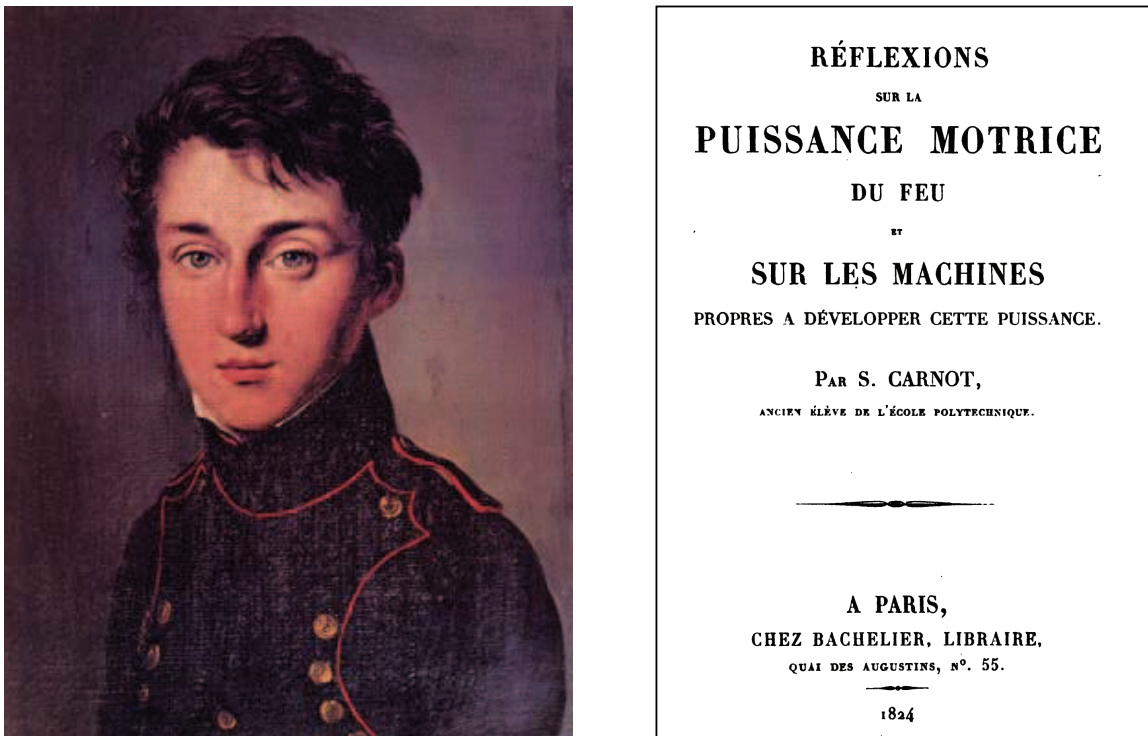

Figure 5.8: Sadi Nicolas Léonard Carnot (1796-1832), French engineer whose analysis formed the basis for modern thermodynamics; image from http://mathshistory.st-andrews.ac.uk/Biographies/Carnot_Sadi.html and the title page from his *magnum opus*.

Carnot's 1824 work was done before any formal notions of the first and second laws had been systematized.

¹¹S. Carnot, 1824, *Réflexions sur la Puissance Motrice du Feu et sur les Machines propres à Développer cette Puissance*, Bachelier, Paris. (English translation, 2005, *Reflections on the Motive Power of Fire*, Dover, Mineola, New York). 1897 English translation.

The informal statement of the Kelvin-Planck version of the second law is that you cannot turn all the heat into work. Now, an engineer often wants to harvest as much as possible of the thermal energy of combustion and convert it into mechanical energy. Kelvin-Planck simply says we cannot have it all. But it lets us have some! In fact if we only harvest a portion of the thermal energy for work and reject the rest in the form of thermal energy, we can satisfy the second law. We show this schematically in Fig. 5.9. The first law for this

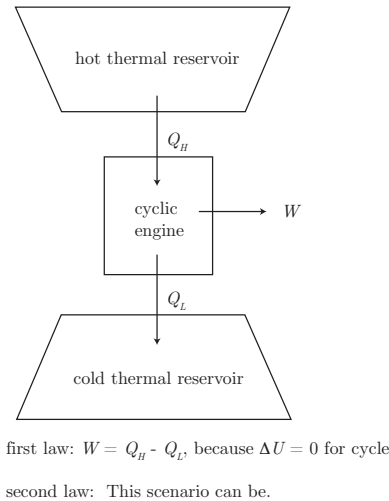

Figure 5.9: Schematic of a realizable heat engine.

system is

$$U_2 - U_1 = Q_H - Q_L - W. \quad (5.4)$$

Note that here, we are thinking of W , Q_H , and Q_L as all positive. If we were rigorous with our sign convention, we would have reversed the arrow on Q_L because our sign convention always has positive work entering the system. However,

- *following a common practice, the rigorous sign convention is traditionally abandoned for analysis of heat engines!*

Now, we are requiring a cyclic process, so $U_1 = U_2$; thus, Eq. (5.4) reduces to

$$W = Q_H - Q_L. \quad (5.5)$$

Now, recall we previewed the idea of thermal efficiency, η , in Eq. (4.329):

$$\eta = \frac{\text{what you want}}{\text{what you pay for}}. \quad (5.6)$$

We recast it for the scenario of Fig. 5.9, where we want W and we pay for Q_H :

$$\eta = \frac{W}{Q_H}. \quad (5.7)$$

Now, we use Eq. (5.5) to eliminate W in Eq. (5.7) and get

$$\eta = \frac{Q_H - Q_L}{Q_H} = 1 - \frac{Q_L}{Q_H}. \quad (5.8)$$

Equation (5.8) is analogous to the earlier Eq. (4.335). Now, if $Q_L = 0$, we get $\eta = 1$, and our engine does a perfect job in converting all the heat into work. But if $Q_L = 0$, we violate the Kelvin-Planck version of the second law! So we must reject *some* heat. Another version of the Kelvin-Planck statement then is

$$\eta = 1 - \frac{Q_L}{Q_H} < 1. \quad (5.9)$$

It is possible to prove the following corollary to the Kelvin-Planck statement:

$$\eta_{irreversible} \leq \eta_{reversible}, \quad (5.10)$$

for cycles operating between the same thermal reservoirs.

And there is a second corollary, applicable for two different cycles, both reversible, and both operating between the same thermal reservoirs:

$$\eta_{reversible,1} = \eta_{reversible,2}. \quad (5.11)$$

Example 5.1

Prove the first corollary, Eq. (5.10).

We show this schematically in Fig. 5.10. In Fig. 5.10a, we have two cyclic engines operating between the same thermal reservoirs. One is reversible, and extracts reversible work, W_R from an input of Q_H . The other engine is irreversible and extracts irreversible work W_I from the same heat input Q_H . Because $W_I \neq W_R$, the two engines reject a different amount of heat to satisfy the first law. The reversible engine rejects Q_L , and the irreversible engine rejects Q'_L .

In Fig. 5.10b, we take formal advantage of the reversibility of one of the engines to reverse all processes, as shown by the different nature of all the arrows. In fact we have created a refrigerator, a device in which a work input is used to move thermal energy from a cold region to a hot region. Now, in this configuration, an identical Q_H is added and removed from the hot thermal reservoir. So the net effect into the system defined by the combined two cyclic engines is that there is no net heat transfer to the combined system. We show this schematically in Fig. 5.11. Now, the combined effect of Fig. 5.11 is in a form suitable for application of the Kelvin-Planck form of the second law. We have the net work as

$$W = W_I - W_R. \quad (5.12)$$

And the Kelvin-Planck statement, from Eq. (5.3) holds that

$$W \leq 0. \quad (5.13)$$

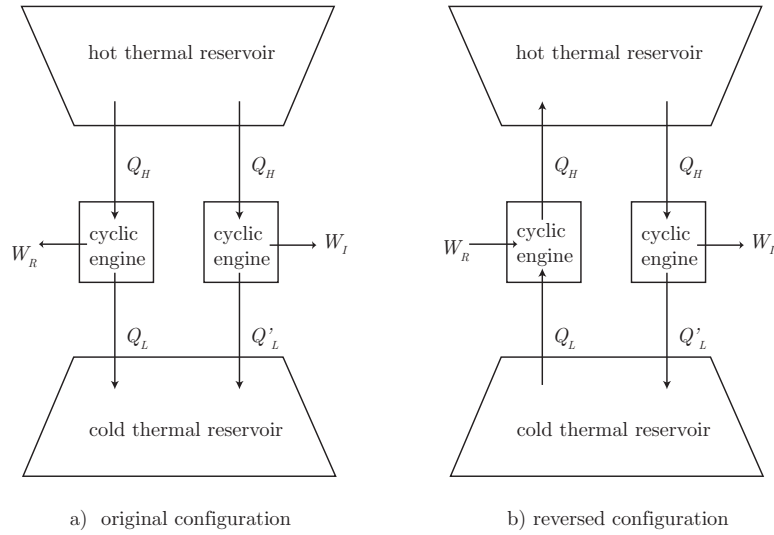

Figure 5.10: Schematic of a heat engine used in proof of the first corollary of the Kelvin-Planck statement of the second law of thermodynamics.

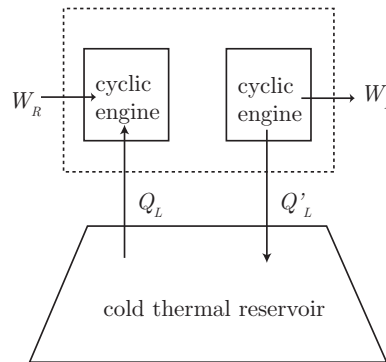

Figure 5.11: Net effect of the configuration from Fig. 5.10b.

Imposing Eq. (5.12) into Eq. (5.3), we get

$$W_I - W_R \leq 0, \quad (5.14)$$

$$W_I \leq W_R. \quad (5.15)$$

Now, the efficiency of the reversible engine from Fig. 5.10a is

$$\eta_{reversible} = \frac{W_R}{Q_H}. \quad (5.16)$$

The efficiency of the irreversible engine from Fig. 5.10a is

$$\eta_{irreversible} = \frac{W_I}{Q_H}. \quad (5.17)$$

And because Q_H is the same in both, and $W_I \leq W_R$, we have proved the first corollary:

$$\eta_{irreversible} \leq \eta_{reversible}. \quad (5.18)$$

The second corollary, Eq. (5.11), can be proved in a similar manner.

5.4 The absolute temperature scale

The second corollary to the Kelvin-Planck statement holds that all reversible engines operating between the same thermal reservoirs have the same η . *This is independent of any details of the cycle or the materials involved.* This implies that

- *The thermal efficiency, η , should depend only on the character of the reservoirs involved.*

Specifically, we will define η in terms of what we will call the TEMPERATURE of the reservoir. This is the classical macroscopic interpretation of temperature. Later statistical theories give it the additional interpretation as a measure of the average translational kinetic energy of molecules of the system. But that is not our approach here! Now, we might suppose that this new thermodynamic property, temperature, should somehow be a measure of how much heat is transferred from one reservoir to another. Moreover, each reservoir will have its own temperature. The hot reservoir will have temperature T_H ; the cold reservoir will have temperature T_L . So we are then saying that

$$\eta = \eta(T_H, T_L). \quad (5.19)$$

As of yet, this functional form is unspecified. Substituting this form into our earlier Eq. (5.8), we get

$$\eta(T_H, T_L) = 1 - \frac{Q_L}{Q_H}. \quad (5.20)$$

This can only be true if Q_L and Q_H have some relation to T_L and T_H . So let us propose a useful definition. We insist that our temperatures take the form of that for a Carnot cycle

$$\boxed{\frac{T_L}{T_H} = \frac{Q_L}{Q_H}}. \quad (5.21)$$

This is just a definition that cannot be argued. Its utility will be seen as its justification, but nothing more. Eq. (5.21) is valid only in the context of a Carnot cycle, and not for other cycles.

Our logic train is that we observe heat engines, such as steam engines seen by Carnot in the early 1800s, doing work as a result of heat transfers. That effect, work, must have a cause. And we are going to assert that the cause is affiliated with a temperature difference.

So far our temperature has been defined only in terms of a ratio. Let us make an arbitrary choice to avoid ratios. We take, for convenience, the temperature of the triple point of water to be 273.15 K. Thus for any system, the local T is

$$T = (273.15 \text{ K}) \left(\frac{Q}{Q_{\text{triple point}}} \right)_{\text{reversible cycle}}. \quad (5.22)$$

This implies we can connect our heat engine to a reservoir maintained at the triple point temperature of water, and measure the associated Q s for the heat engine. With our definition, Eq. (5.21), our thermal efficiency, Eq. (5.8), becomes

$$\boxed{\eta = 1 - \frac{T_L}{T_H}}. \quad (5.23)$$

This famous formula is the thermal efficiency for an idealized heat engine; it is not valid for other heat engines. This formula is not found in Carnot's original work; nor is it straightforwardly presented in the later works of the 1850s. Clausius puts most of the pieces in place,¹² so much so that Müller and Müller¹³ attribute the formula to him; but it is not directly seen in his 1854 study; see Truesdell.¹⁴

Note

$$\lim_{T_L \rightarrow 0} \eta = 1, \quad (5.24)$$

$$\lim_{T_H \rightarrow \infty} \eta = 1. \quad (5.25)$$

These two statements have practical importance. While we would like to drive our efficiency to be as close to unity as possible, nature limits us. Generally, we have little to no control over the environmental temperature T_L , so it is a lower bound, usually around $T_L \sim 300$ K. And material properties for engines limit T_H . For many metals, $T_H \sim 1500$ K is approaching values where material strength is lost. So a practical upper bound based on these numbers tells us $\eta \sim 1 - (300 \text{ K})/(1500 \text{ K}) = 0.8$ is maybe the most we can expect. We plot η as a function of T_H for fixed $T_L = 300$ K in Fig. 5.12. For real systems, with irreversible features, the values are much worse.

5.5 Analysis of Carnot refrigerators and heat pumps

A refrigerator or heat pump is a device that, with work input, moves thermal energy from cold regions to hot regions. Without the work input, this could not be achieved, as it would violate the Clausius statement of the second law of thermodynamics. We show this schematically in Fig. 5.13. For a refrigerator, we define a coefficient of performance β ,

¹²R. Clausius, 1854, "Ueber eine veränderte Form des aweiten Hauptsatzes der mechanischen Wärmetheorie," *Annalen der Physik und Chemie*, 169(12): 481-506.

¹³I. Müller and W. H. Müller, 2009, *Fundamentals of Thermodynamics and Applications with Historical Annotations and many Citations from Avogadro to Zermelo*, Springer, Berlin, p. 131.

¹⁴C. Truesdell, 1980, *The Tragicomical History of Thermodynamics, 1822-1854*, Springer, New York, p. 330.

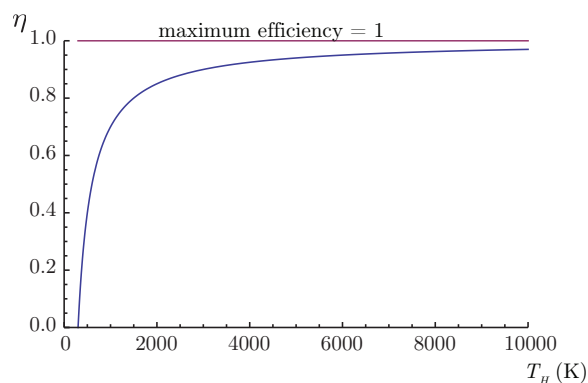

Figure 5.12: Plot of idealized thermal efficiency as a function of hot thermal reservoir temperature with $T_L = 300$ K.

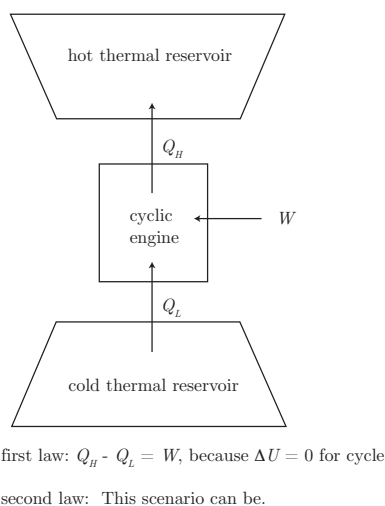

Figure 5.13: Schematic of a realizable refrigerator or heat pump.

sometimes called *COP*, as

$$\beta = \frac{\text{what you want}}{\text{what you pay for}} = \frac{Q_L}{W}, \quad \text{Carnot refrigerator.} \quad (5.26)$$

Now, the first law for this cycle gives $W = Q_H - Q_L$, so

$$\beta = \frac{Q_L}{Q_H - Q_L} = \frac{1}{\frac{Q_H}{Q_L} - 1} = \frac{1}{\frac{T_H}{T_L} - 1}, \quad \text{Carnot refrigerator.} \quad (5.27)$$

Note that

$$\beta \geq 0, \quad (5.28)$$

for $T_H/T_L \geq 1$. In addition, it is possible to have $\beta > 1$ if $T_H/T_L < 2$. Because we reserve efficiencies to have $0 \leq \eta \leq 1$, the *COP* is not really an efficiency. But it is a useful measure that is used as an industry standard for refrigerators.

For heat pumps, we want to bring Q_H into a warm room from a cold outdoors to make the warm room warmer. So it has a related *COP*, that we define as β' :

$$\beta' = \frac{Q_H}{W}, \quad \text{Carnot heat pump.} \quad (5.29)$$

Again the first law gives $W = Q_H - Q_L$, so

$$\beta' = \frac{Q_H}{Q_H - Q_L} = \frac{1}{1 - \frac{Q_L}{Q_H}} = \frac{1}{1 - \frac{T_L}{T_H}}, \quad \text{Carnot heat pump.} \quad (5.30)$$

For $T_L/T_H \leq 1$, we have $\beta' \geq 1$.

Note for both refrigerators and heat pumps, as $W \rightarrow 0$, both $\beta \rightarrow \infty$ and $\beta' \rightarrow \infty$, and we transfer thermal energy from a cold reservoir to a hot one, in violation of the Clausius statement of the second law.

Example 5.2

The inside of a refrigerator is held at $T_L = 3^\circ\text{C}$. The surroundings are at $T_H = 27^\circ\text{C}$. We must remove 1.25 kW of thermal energy from the inside of the refrigerator to balance the thermal energy entering from the environment. Find the best possible coefficient of performance β and the minimum power requirement to operate the refrigerator.

First, we need to convert to an absolute scale. So $T_L = 3 + 273.15 = 276.15\text{ K}$, and $T_H = 300.15\text{ K}$. The problem is sketched in Fig. 5.14. We have

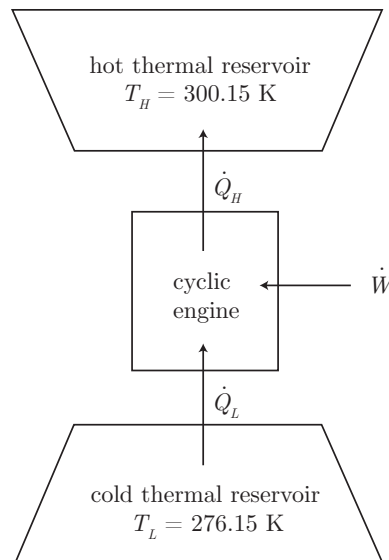

Figure 5.14: Schematic of a Carnot refrigerator diagram for our example.

$$\beta = \frac{1}{\frac{T_H}{T_L} - 1} = \frac{1}{\frac{300.15\text{ K}}{276.15\text{ K}} - 1} = 11.5063. \quad (5.31)$$

Now,

$$\beta = \frac{\text{what we want}}{\text{what we pay for}} = \frac{\dot{Q}_L}{\dot{W}}. \quad (5.32)$$

Thus

$$\dot{W} = \frac{\dot{Q}_L}{\beta} = \frac{1.25 \text{ kW}}{11.5063} = 0.108367 \text{ kW}. \quad (5.33)$$

Note the rules of heat transfer determine the energy load needed to keep the temperature constant. We have not considered those here. This is the smallest possible engine that would be needed. Inefficiencies would cause the actual size needed to be higher.

5.6 Rejected thermal energy on a national scale

We see that the second law characterizes the necessary rejection of heat in processes involving heat and work. Let us briefly examine this on a national scale. Figure 5.15 reports US energy

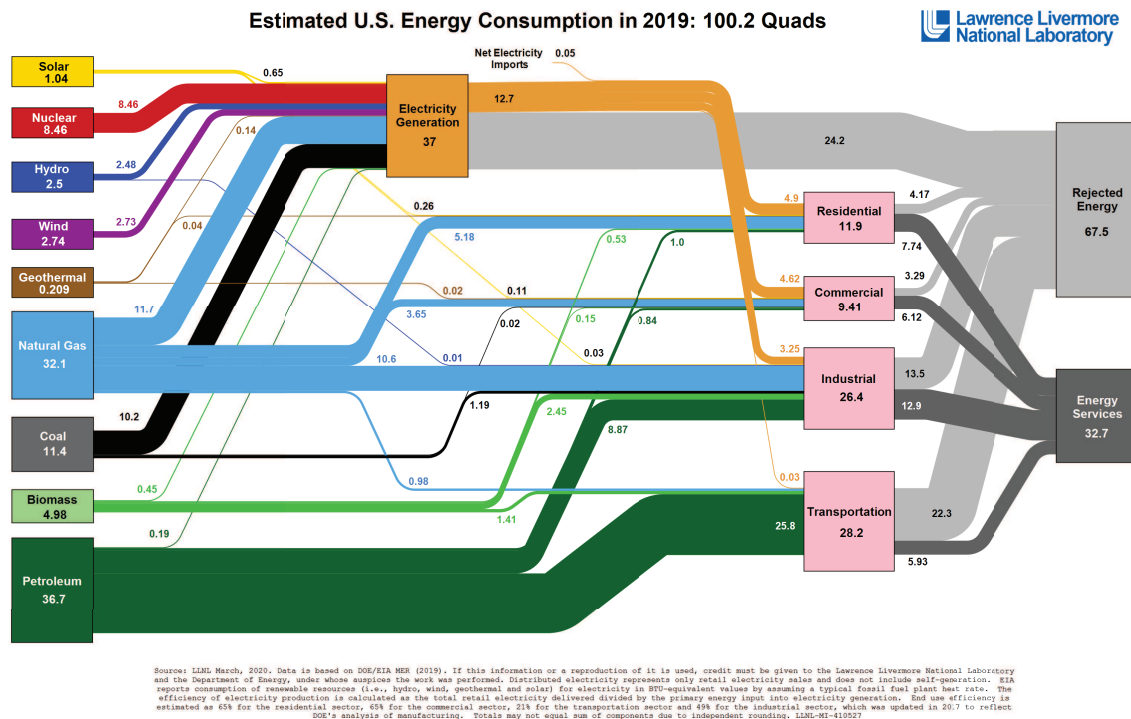

Figure 5.15: Chart of distribution of energy sources and usage in the US in 2019. Data from Lawrence Livermore National Laboratory, <https://flowcharts.llnl.gov/>.

usage in 2019 from a wide variety of sources directed to a wide variety of applications. The basic unit of energy here is the quad where $1 \text{ quad} = 10^{15} \text{ Btu} = 1.055 \times 10^{18} \text{ J} = 1.055 \text{ EJ}$,

where EJ is an “exajoule.” Much can be gleaned from this chart. Overall US energy use is estimated at 100.2 quad for the year indicated. As far as the second law is concerned, electricity generation rejects 24.2 quad waste heat per annum and transportation rejects 22.3 quad waste heat per annum. In total, 67.5 quad is rejected, and 32.7 quad is directed towards a useful intended purpose. Thus, the thermal efficiency of the US in 2018 was

$$\eta_{US} = \frac{32.7 \text{ quad}}{(32.7 \text{ quad}) + (67.5 \text{ quad})} = 0.326. \quad (5.34)$$

Figure 5.16 shows a comparable plot for 2011. One can see evolution of the energy

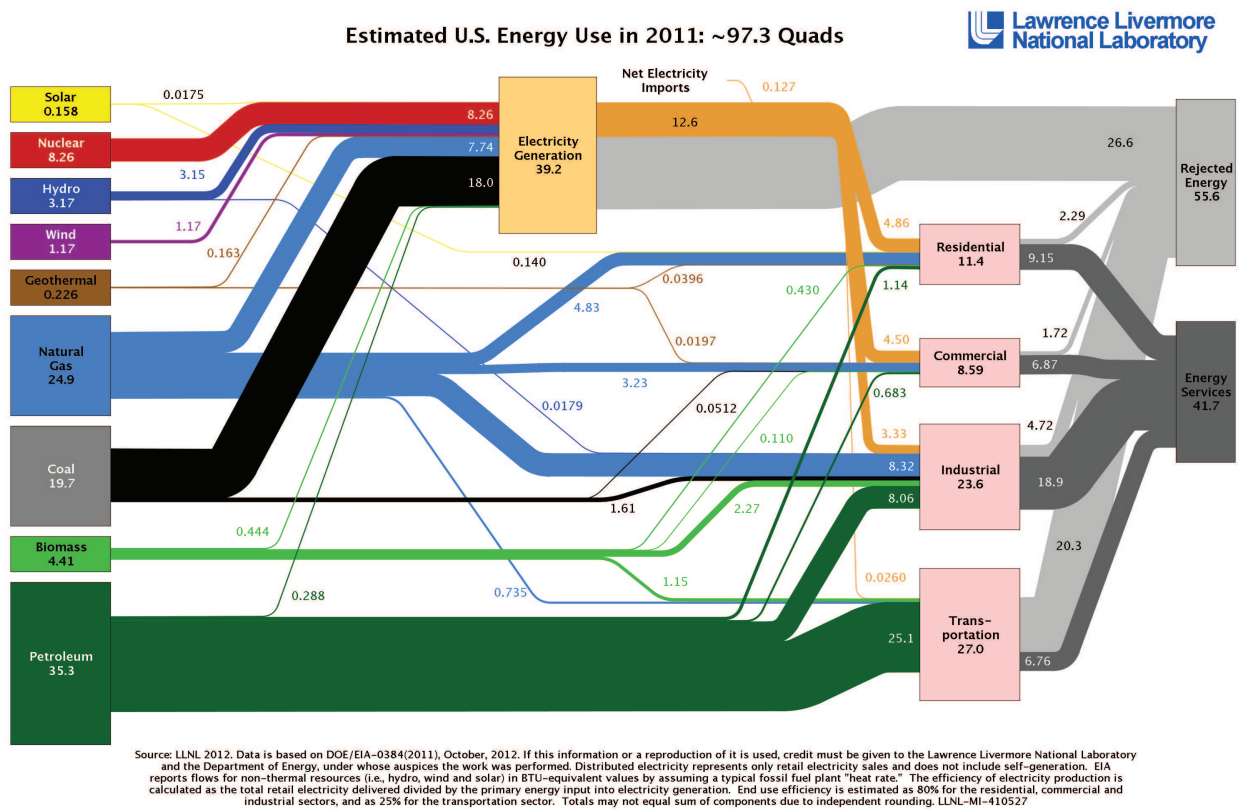

Figure 5.16: Chart of distribution of energy sources and usage in the US in 2011. Data from Lawrence Livermore National Laboratory, <https://flowcharts.llnl.gov/>.

budget.

Example 5.3

If all the waste heat in the US in 2019 were directed into Lake Michigan, find its temperature rise.

In more convenient units, the waste heat for a given year is

$$Q = (67.5 \text{ quad}) \left(\frac{1.055 \times 10^{18} \text{ J}}{\text{quad}} \right) = 7.12 \times 10^{19} \text{ J}. \quad (5.35)$$

Now, Lake Michigan has a volume of 4900 km³. Therefore the mass of water in Lake Michigan is roughly

$$m = \rho V = \left(997 \frac{\text{kg}}{\text{m}^3}\right) (4900 \text{ km}^3) \left(\frac{10^3 \text{ m}}{\text{km}}\right)^3 = 4.88 \times 10^{15} \text{ kg}. \quad (5.36)$$

If all the waste energy were dumped into Lake Michigan, we could expect from a first law analysis to find a temperature rise of

$$\Delta T = \frac{Q}{mc_P} = \frac{7.12 \times 10^{19} \text{ J}}{(4.88 \times 10^{15} \text{ kg}) \left(4180 \frac{\text{J}}{\text{kg K}}\right)} = 3.5 \text{ K}. \quad (5.37)$$

Locally on the University of Notre Dame campus, both St. Mary's and St. Joseph's Lakes would be vaporized many times over.

Chapter 6

Entropy

Read BS, Chapter 6

Much as the new property energy arose via consideration of the first law of thermodynamics, we will find it useful to introduce

- **ENTROPY:** a thermodynamic property that provides a quantitative measure of the disorder of a given thermodynamic state,

from consideration of the second law of thermodynamics. The word itself was coined by Clausius,¹ who based it on the combination of $\epsilon\nu$ - (en-) “to put into,” and $\tau\rho\pi\eta$ (tropē), “turn” or “conversion.” The Greek here is a modification of the original Greek of Clausius, who employed η $\tau\rho\pi\eta$. An image of the first use of the word is given in Fig. 6.1.

In some ways entropy is simply a mathematical convenience and a theoretical construct. However, its resilience is due to the fact that it is useful for engineers to summarize important design concepts for thermal systems such as steam power plants, automobile engines, jet engines, refrigerators, heat pumps, and furnaces.

6.1 Theoretical development

Let us motivate the property of entropy by considering Fig. 6.2. Here, we perform our analysis on a differential basis. We have a thermal reservoir at T_{res} that delivers a small amount of heat $\delta Q'$ to a reversible cyclic engine, labeled “1.” This engine delivers a small amount of work $\delta W'$ and rejects a small amount of heat δQ to another reservoir at variable T , labeled “2.” Let us examine the implications of our temperature definition and the second law of thermodynamics on this scenario.

¹R. Clausius, 1865, “Ueber verschiedene für die Anwendung bequeme Formen der Hauptgleichungen der mechanischen Wärmetheorie,” *Annalen der Physik und Chemie*, 125(7): 353-390.

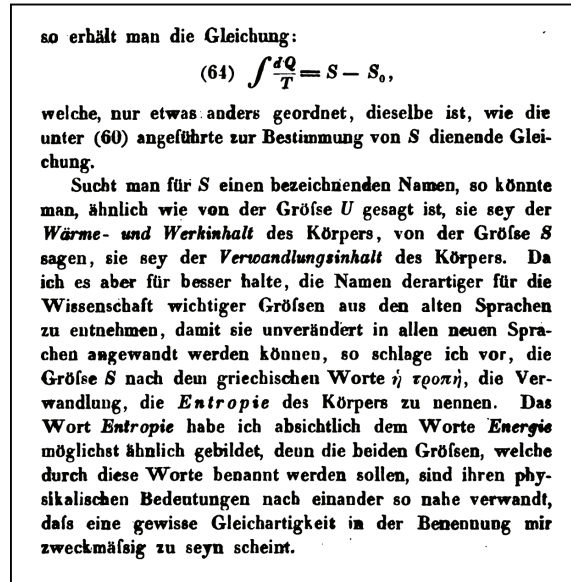

Figure 6.1: Image capturing the first use of the word entropy, from R. Clausius, 1865.

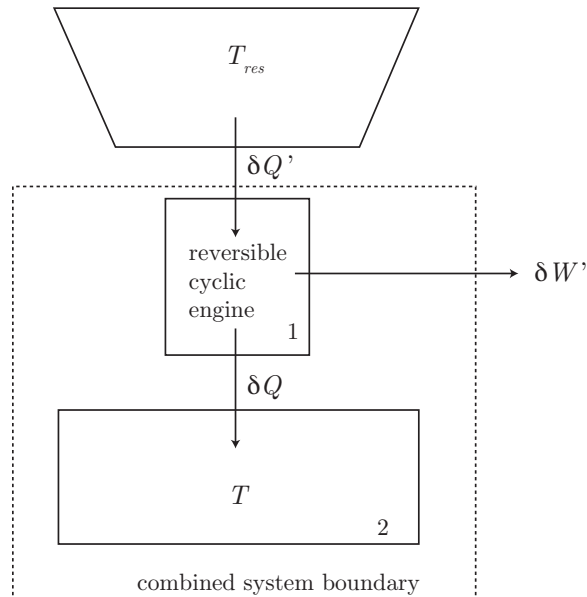

Figure 6.2: Sketch of heat engine configuration to motivate the development of entropy.

We first apply Eq. (5.21) to the configuration of Fig. 6.2:

$$\frac{\delta Q'}{\delta Q} = \frac{T_{res}}{T}. \quad (6.1)$$

Thus

$$\frac{\delta Q'}{T_{res}} = \frac{\delta Q}{T}. \quad (6.2)$$

Now, let us take the combined system, enclosed within the dotted box, to be composed of 1 and 2. The first law in differential form for the combined system is

$$dE = \delta Q' - \delta W'. \quad (6.3)$$

Note that we have not yet required the process be cyclic. Also note that δQ is *internal* and so does not cross the boundary of the combined system and is not present in our first law formulation. Rearrange Eq. (6.3) to get

$$\delta W' = \delta Q' - dE. \quad (6.4)$$

Now, use Eq. (6.2) to eliminate $\delta Q'$ in Eq. (6.4):

$$\delta W' = T_{res} \frac{\delta Q}{T} - dE. \quad (6.5)$$

Now, let us let this configuration undergo a thermodynamic cycle, indicated by the operation \oint applied to Eq. (6.5):

$$\oint \delta W' = \oint T_{res} \frac{\delta Q}{T} - \underbrace{\oint dE}_{=0}. \quad (6.6)$$

Because E is a thermodynamic property, its cyclic integral is zero. But Q and W are not properties, so they have non-zero values when integrated through a cycle. Performing the integration of Eq. (6.6) and realizing that, by definition, T_{res} is a constant, we get

$$W' = T_{res} \oint \frac{\delta Q}{T}. \quad (6.7)$$

Now, we can apply the Kelvin-Planck form of the second law of thermodynamics, Eq. (5.3), to the configuration of Fig. 6.2; thus, we require simply that

$$W' \leq 0. \quad (6.8)$$

That is, we cannot convert all the heat to work, but we can convert all the work to heat. Because Kelvin-Planck tells us $W' \leq 0$, Eq. (6.7) tells us

$$T_{res} \oint \frac{\delta Q}{T} \leq 0. \quad (6.9)$$

And because $T_{res} > 0$, we can divide Eq. (6.9) by it without changing the sense of the inequality to get a mathematical representation of the second law of thermodynamics:

$$\boxed{\oint \frac{\delta Q}{T} \leq 0,} \quad (6.10)$$

second law of thermodynamics.

If all processes are reversible, we lose the inequality, and get simply

$$\boxed{\oint \frac{\delta Q}{T} = 0,} \quad (6.11)$$

all processes reversible.

Now, let us reconsider Fig. 3.26, recast here as Fig. 6.3, that was used for development of the path-independent thermodynamic property E . Here, we will use similar concepts to develop the thermodynamic property of entropy. Let us restrict our discussion to reversible

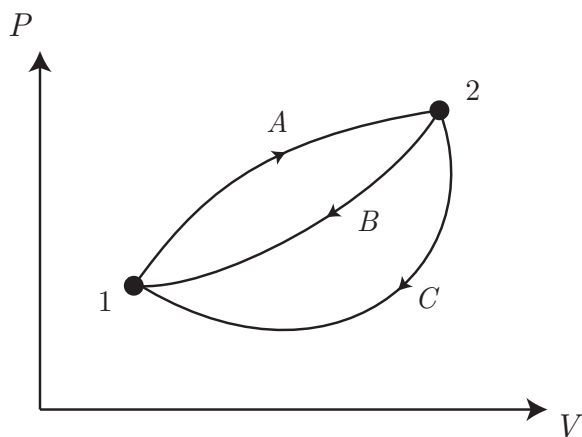

Figure 6.3: Sketch of $P - V$ diagram for various combinations of processes forming cyclic integrals.

processes, that are the best we could hope for in an ideal world. So we demand that Eq. (6.11) holds.

Now, from Fig. 6.3, consider starting from 1, proceeding on path A to 2, and returning to 1 via path B . The cyclic integral $\oint \delta Q/T = 0$ decomposes to

$$\left(\int_1^2 \frac{\delta Q}{T} \right)_A + \left(\int_2^1 \frac{\delta Q}{T} \right)_B = 0. \quad (6.12)$$

Now, perform the same exercise going from 1 to 2 on path A and returning on path C , yielding

$$\left(\int_1^2 \frac{\delta Q}{T}\right)_A + \left(\int_2^1 \frac{\delta Q}{T}\right)_C = 0. \quad (6.13)$$

Now, subtract Eq. (6.13) from Eq. (6.12) to get

$$\left(\int_2^1 \frac{\delta Q}{T}\right)_B - \left(\int_2^1 \frac{\delta Q}{T}\right)_C = 0. \quad (6.14)$$

Thus

$$\left(\int_2^1 \frac{\delta Q}{T}\right)_B = \left(\int_2^1 \frac{\delta Q}{T}\right)_C. \quad (6.15)$$

We can reverse direction and recover the same result, because $\int_2^1 = -\int_1^2$:

$$\left(\int_1^2 \frac{\delta Q}{T}\right)_B = \left(\int_1^2 \frac{\delta Q}{T}\right)_C. \quad (6.16)$$

Because paths B and C are different and arbitrary, but $\int_1^2 \delta Q/T$ is the same on either path, the integral must be *path-independent*. It therefore defines a thermodynamic property of the system. We define that property as entropy, S , an extensive thermodynamic property:

$$\boxed{S_2 - S_1 = \int_1^2 \frac{\delta Q}{T}.} \quad (6.17)$$

Note the units of S must be kJ/K in the SI system. We also can scale by the constant mass m to get the corresponding intensive property $s = S/m$:

$$\boxed{s_2 - s_1 = \int_1^2 \frac{\delta q}{T}.} \quad (6.18)$$

The units for s are kJ/kg/K; note they are the same as c_P , c_v , and R . In differential form, we can say

$$\boxed{ds = \frac{\delta q}{T}.} \quad (6.19)$$

This leads us to

$$\boxed{\delta q = T ds.} \quad (6.20)$$

Integrating Eq. (6.20), we get

$$\int_1^2 \delta q = \int_1^2 T ds. \quad (6.21)$$

Thus, we get

$$\boxed{{}_1q_2 = \int_1^2 T ds.} \quad (6.22)$$

This is the heat transfer equivalent to ${}_1w_2 = \int_1^2 P dv$. So we see the heat transfer for a process from 1 to 2 is given by the area under the curve in the $T - s$ plane; see Fig. 6.4. Note if our process lies on a so-called

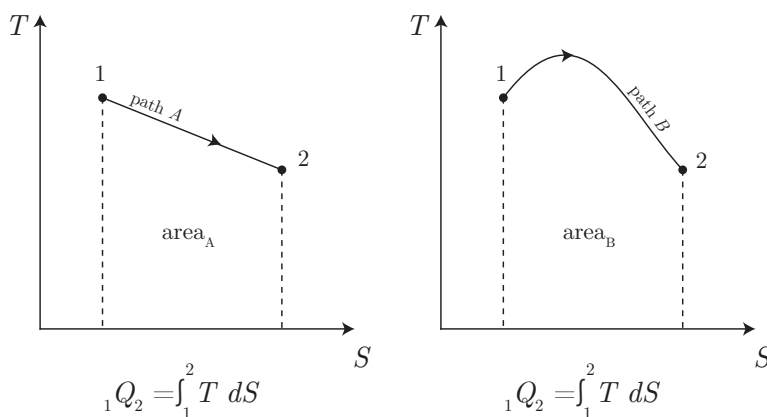

Figure 6.4: Sketch of process in the $T - s$ plane, with the associated heat transfer.

- **ISENTROPE:** a curve on which entropy s is constant,

then by Eq. (6.22), ${}_1q_2 = 0$; thus, the process is adiabatic. Now, Eq. (6.22) only applies for a reversible process. Combining these notions, we summarize with the important equivalence:

$$\boxed{\text{isentropic} = \text{adiabatic} + \text{reversible}.}$$

For problems in which no chemical reactions are present, we will find ourselves interested only in entropy differences. For problems with chemical reactions, the absolute values of entropy will be important. Such values can be obtained by consideration of the

- **THIRD LAW OF THERMODYNAMICS:** “every substance has a finite positive entropy, but at the absolute zero of temperature the entropy may become zero, and does so become in the case of perfect crystalline substances,”

quoted here from Lewis and Randall.² The law, another axiom of thermodynamics, was developed over several years by Nernst,³ depicted in Fig. 6.5. It will not be considered

²G. N. Lewis and M. Randall, 1923, *Thermodynamics and the Free Energy of Chemical Substances*, McGraw-Hill, New York, p. 448.

³e.g. W. H. Nernst, 1906, Ueber die Berechnung chemischer Gleichgewichte aus thermischen Messungen, *Nachrichten von der Königlichen Gesellschaft der Wissenschaften zu Göttingen, Mathematisch-physikalische Klasse*, Weidmannsche Buchhandlung, Berlin.



Figure 6.5: Walther Hermann Nernst (1864-1941), German physical chemist who developed the third law of thermodynamics; image from https://en.wikipedia.org/wiki/Walther_Nernst.

further here.

Because entropy is a thermodynamic property, it can be used to help determine the state. That is we can say any of the following:

$$s = s(T, v), \quad s = s(T, P), \quad s = s(v, x), \quad P = P(T, s), \quad v = v(P, s), \quad \dots \quad (6.23)$$

For two-phase mixtures, we have, as expected,

$$s = s_f + xs_{fg}, \quad s = s_f + x(s_g - s_f), \quad s = (1 - x)s_f + xs_g, \quad x = \frac{s - s_f}{s_{fg}}. \quad (6.24)$$

6.2 Second law in terms of entropy

We now have a statement of the second law, $\oint \delta Q/T \leq 0$, valid for reversible or irreversible heat transfer, and a definition of entropy $S_2 - S_1 = \int_1^2 \delta Q/T$, provided the heat transfer is reversible. The two seem similar. Let us combine them to cast the second law in terms of entropy. Consider the cycle in the $T - S$ diagram of Fig. 6.6. We start at 1, and proceed to 2 along path I , that represents an irreversible process. We return from 2 to 1 along path R , that represents a reversible process. The second law, Eq. (6.10), holds

$$\oint \frac{\delta Q}{T} \leq 0, \quad (6.25)$$

$$0 \geq \oint \frac{\delta Q}{T}. \quad (6.26)$$

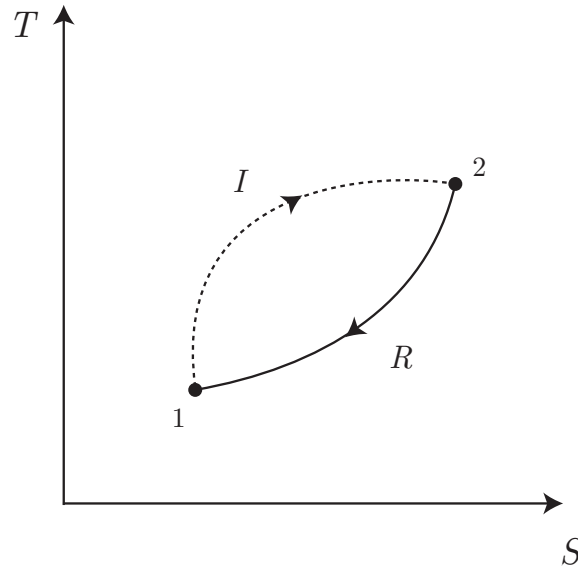

Figure 6.6: Sketch of cycle in the $T - S$ plane composed of irreversible process I from 1 to 2, followed by reversible process R from 2 back to 1.

The equality implies all processes are reversible; the inequality implies some portion of the process is irreversible. Now, for a reversible process we also have

$$S_2 - S_1 = \int_1^2 \frac{\delta Q}{T}. \quad (6.27)$$

Because the process is reversible, we can reverse to get

$$S_1 - S_2 = \int_2^1 \frac{\delta Q}{T}. \quad (6.28)$$

Now, apply the second law, Eq. (6.10), to the scenario of Fig. 6.6:

$$0 \geq \left(\int_1^2 \frac{\delta Q}{T} \right)_I + \left(\int_2^1 \frac{\delta Q}{T} \right)_R. \quad (6.29)$$

Now, substitute Eq. (6.28) into Eq. (6.29) to eliminate the integral along R to get

$$0 \geq \left(\int_1^2 \frac{\delta Q}{T} \right)_I + S_1 - S_2, \quad (6.30)$$

$$S_2 - S_1 \geq \left(\int_1^2 \frac{\delta Q}{T} \right)_I. \quad (6.31)$$

More generally, we can write the second law of thermodynamics as

$$\boxed{S_2 - S_1 \geq \int_1^2 \frac{\delta Q}{T}.} \quad (6.32)$$

If $1 \rightarrow 2$ is reversible, the equality holds; if $1 \rightarrow 2$ is irreversible, the inequality holds.

Now, *if the system is isolated*, there can be no heat transfer interactions and $\delta Q = 0$. So

$$\boxed{S_2 - S_1 \geq 0}, \quad (6.33)$$

isolated system.

This implies 2 occurs later in time than 1. Thus, for isolated systems, the entropy increases as time moves forward.

Example 6.1

Two large thermal reservoirs, one at T_A and the other at T_B , exchange a finite amount of heat Q with no accompanying work exchange. The reservoirs are otherwise isolated and thus form their own universe, when considered as a combined system. Consider the implications for entropy and the second law.

The scenario is sketched in Fig. 6.7. Assume for now that positive Q leaves A and enters B . Both A

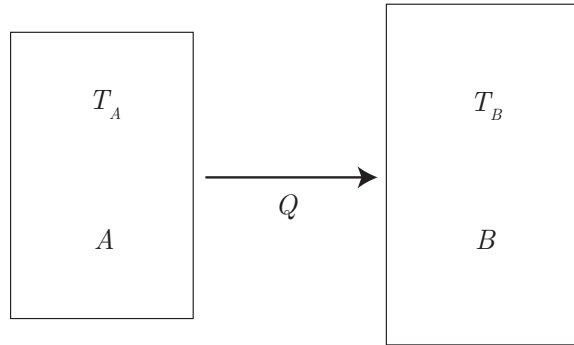

Figure 6.7: Sketch of heat transfer from A to B .

and B are so massive that the respective loss and gain of thermal energy does not alter their respective temperatures. Consider the entropy changes for each system:

$$S_{A2} - S_{A1} = \int_1^2 \frac{\delta Q}{T} = \frac{1}{T_A} \int_1^2 \delta Q = -\frac{Q}{T_A}, \quad (6.34)$$

$$S_{B2} - S_{B1} = \int_1^2 \frac{\delta Q}{T} = \frac{1}{T_B} \int_1^2 \delta Q = \frac{Q}{T_B}. \quad (6.35)$$

The entropy change for A is negative because Q was negative for A ; the entropy change for B is positive because Q for B was positive. Now, our universe is the combination of A and B , so the entropy change of the universe is found by adding the entropy changes of the components of the universe:

$$\underbrace{(S_{A2} + S_{B2})}_{=S_{U2}} - \underbrace{(S_{A1} + S_{B1})}_{=S_{U1}} = \frac{Q}{T_B} - \frac{Q}{T_A}. \quad (6.36)$$

With the universe entropy S_U as $S_U = S_A + S_B$, we get

$$S_{U2} - S_{U1} = Q \left(\frac{1}{T_B} - \frac{1}{T_A} \right). \quad (6.37)$$

The universe is isolated, so the second law holds that $S_{U2} - S_{U1} \geq 0$; thus,

$$Q \left(\frac{1}{T_B} - \frac{1}{T_A} \right) \geq 0. \quad (6.38)$$

Now, we have assumed $Q > 0$; therefore, we can divide by Q without changing the sense of the inequality:

$$\frac{1}{T_B} - \frac{1}{T_A} \geq 0, \quad (6.39)$$

$$\frac{T_A - T_B}{T_A T_B} \geq 0. \quad (6.40)$$

Because $T_A > 0$ and $T_B > 0$, we can multiply both sides by $T_A T_B$ without changing the sense of the inequality to get

$$T_A - T_B \geq 0, \quad (6.41)$$

$$T_A \geq T_B. \quad (6.42)$$

We have thus confirmed that our mathematical formulation of the second law in terms of entropy yields a result consistent with the Clausius statement of the second law. We must have $T_A \geq T_B$ in order to transfer positive heat Q from A to B .

Example 6.2

We have $m = 10$ kg of liquid water at $T_1 = 0$ °C. The water freezes, and its final state is solid water at $T_2 = 0$ °C. Give a second law analysis.

Let us assume reversible processes. For the water, we have

$$S_2 - S_1 = m \int_1^2 \frac{\delta q}{T}. \quad (6.43)$$

While we can use the steam tables to find the heats of vaporization and sublimation for water, there are no values listed for the liquid-solid transition process. We consult other sources, and quickly find the heat of fusion for water estimated as $\Delta h_{fusion} = 333.55$ kJ/kg. We will ignore work because the density change is not great (though it is not zero). Now, the water will have ${}_1q_2 = -\Delta h_{fusion}$ as it solidifies, because it is losing energy. The temperature is constant, so we get

$$S_2 - S_1 = \frac{m}{T} \int_1^2 \delta q = \frac{m_1 q_2}{T} = \frac{(10 \text{ kg}) \left(-333.55 \frac{\text{kJ}}{\text{kg}} \right)}{(0 + 273.15 \text{ K})} = -12.2112 \frac{\text{kJ}}{\text{K}}. \quad (6.44)$$

Note that ice has more structure, i.e. less randomness, than liquid water. This is reflected in the drop of entropy.

In order for this process to have taken place, the surroundings must have received a transfer of $(10 \text{ kg})(333.55 \text{ kJ/kg}) = 3335.5$ kJ of energy. For this to have occurred, we would need $T_{surr} \leq 0$ °C. Say the surroundings were at -10 °C. Then their entropy would have increased via

$$\Delta S_{surr} = \frac{3335.5 \text{ kJ}}{(-10 + 273.15) \text{ K}} = 12.6753 \frac{\text{kJ}}{\text{K}}. \quad (6.45)$$

Thus, the entropy of the universe would have went up by

$$\Delta S_{univ} = \left(-12.2112 \frac{\text{kJ}}{\text{K}}\right) + \left(12.6753 \frac{\text{kJ}}{\text{K}}\right) = 0.4641 \frac{\text{kJ}}{\text{K}}. \quad (6.46)$$

Example 6.3

Given saturated ammonia vapor at $P_1 = 200$ kPa compressed by a piston to $P_2 = 1.6$ MPa in a reversible adiabatic process, find the work done per unit mass.

Consider the diagram of in Fig. 6.8. The fact that the compression is reversible and adiabatic

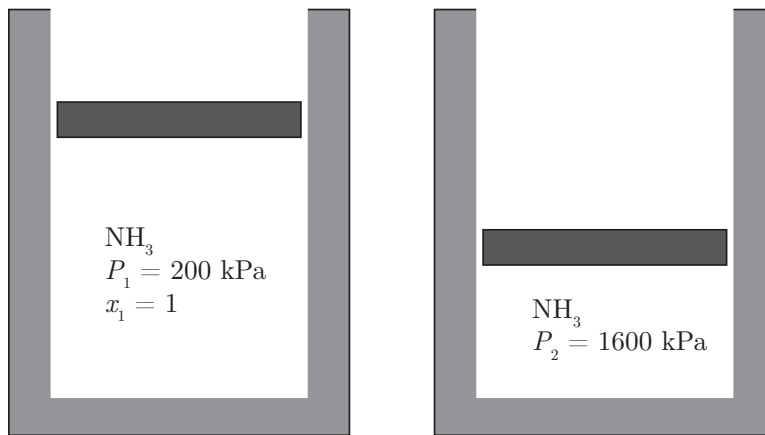

Figure 6.8: Schematic for adiabatic reversible (isentropic) compression of ammonia problem.

implies that it is an isentropic process. If this were a CPIG, we could use algebraic equations, to be developed, to calculate state 2. But these equations are not valid for materials such as ammonia (NH_3) near the vapor dome. So, we consult the tables.

Interpolation of Table B.2.1 of BS tells us that

$$s_1 = 5.6034 \frac{\text{kJ}}{\text{kg K}}, \quad u_1 = 1301.3 \frac{\text{kJ}}{\text{kg}}, \quad T_1 = -18 \text{ }^\circ\text{C}, \quad v_1 = 0.598902 \frac{\text{m}^3}{\text{kg}}. \quad (6.47)$$

Because the process is isentropic,

$$s_2 = s_1 = 5.6034 \frac{\text{kJ}}{\text{kg K}}. \quad (6.48)$$

The saturation tables, BS's B.2.1, tell us that near $P_2 = 1600$ kPa, that $s_g \sim 4.8$ kJ/kg/K. Because $s_2 > s_g$, the ammonia is superheated at this state. Knowing P_2 and s_2 , we turn to BS's Table B.2.2 to find by linear interpolation that

$$T_2 = 134.9 \text{ }^\circ\text{C}, \quad u_2 = 1548.4 \frac{\text{kJ}}{\text{kg}}, \quad v_2 = 0.118337 \frac{\text{m}^3}{\text{kg}}. \quad (6.49)$$

Note that T_2 is just above the critical temperature of ammonia, that is $T_c = 132.3\text{ }^\circ\text{C}$. But P_2 is well below the critical pressure, that is $P_c = 11333.2\text{ kPa}$. Note also that $v_2 < v_1$.

Now, the first law of thermodynamics tells us that

$$u_2 - u_1 = \underbrace{{}_1q_2}_{=0} - {}_1w_2. \quad (6.50)$$

Because the process is isentropic, ${}_1q_2 = 0$, and

$${}_1w_2 = u_1 - u_2 = \left(1301.3 \frac{\text{kJ}}{\text{kg}}\right) - \left(1548.4 \frac{\text{kJ}}{\text{kg}}\right) = \boxed{-247 \frac{\text{kJ}}{\text{kg}}}. \quad (6.51)$$

With considerable effort we could have also constructed ${}_1w_2$ by integration of the $P - v$ diagram along an isentrope.

The process is sketched in Fig. 6.9.

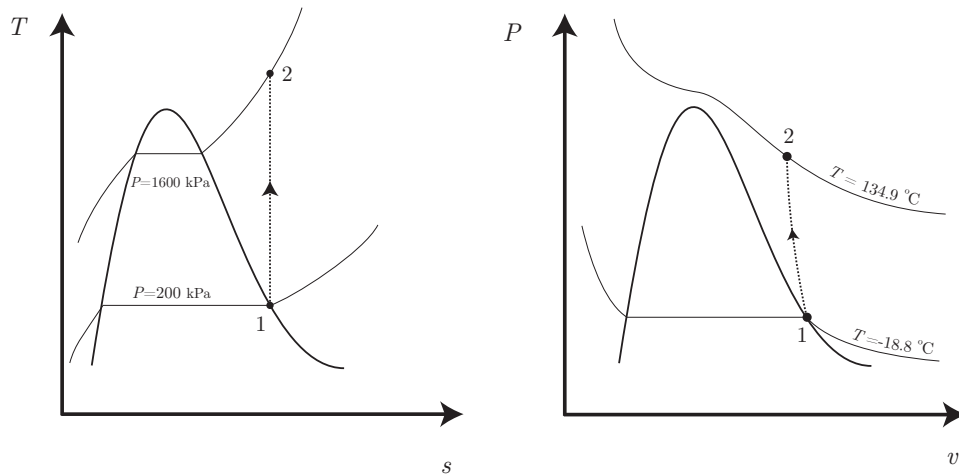

Figure 6.9: $T - s$ and $P - v$ diagrams for adiabatic reversible (isentropic) compression of ammonia problem.

Example 6.4

Liquid water at $P_1 = 100\text{ kPa}$, $x_1 = 0$ is heated isobarically until $T_2 = 200\text{ }^\circ\text{C}$. Find the heat added.

The tables tell us that at state 1, we have $T_1 = 99.62\text{ }^\circ\text{C}$, $v_1 = 0.001043\text{ m}^3/\text{kg}$, $h_1 = 417.44\text{ kJ/kg}$, and $s_1 = 1.3025\text{ kJ/kg/K}$. We note an intermediate stage i when $x_g = 1$ that $T_g = T_1 = 99.62\text{ }^\circ\text{C}$, $h_g = 2675.46\text{ kJ/kg}$, and $s_g = 7.3593\text{ kJ/kg/K}$. At the final state, the superheat tables give us $v_2 = 2.17226\text{ m}^3/\text{kg}$, $h_2 = 2875.27\text{ kJ/kg}$, and $s_2 = 7.8342\text{ kJ/kg/K}$.

For the isobaric process, we have the heat transfer given by Δh . For the part of the process under the dome, we have

$${}_1q_g = h_g - h_1 = \left(2675.46 \frac{\text{kJ}}{\text{kg}}\right) - \left(417.44 \frac{\text{kJ}}{\text{kg}}\right) = 2258.02 \frac{\text{kJ}}{\text{kg}}. \quad (6.52)$$

This quantity is the latent heat. It represents heat added without increase in temperature. It is easily calculated by an independent method. We also have ${}_1q_g = \int_1^g T ds$. Because an isobaric process under the vapor dome is also isothermal, we can say ${}_1q_g = T(s_g - s_1)$, so

$${}_1q_g = (99.62 + 273.15) (\text{K}) \left(\left(7.2593 \frac{\text{kJ}}{\text{kg K}}\right) - \left(1.3025 \frac{\text{kJ}}{\text{kg K}}\right) \right) = 2257.79 \frac{\text{kJ}}{\text{kg}}. \quad (6.53)$$

The difference in the two predictions can be attributed to rounding error.

For the part of the process outside of the dome, we have

$${}_gq_2 = h_2 - h_g = \left(2875.27 \frac{\text{kJ}}{\text{kg}}\right) - \left(2675.46 \frac{\text{kJ}}{\text{kg}}\right) = 199.81 \frac{\text{kJ}}{\text{kg}}. \quad (6.54)$$

This quantity is the sensible heat. It represents heat added with an increase in temperature. We can sense it. It could also be calculated via numerical integration of ${}_gq_2 = \int_g^2 T ds$ for this non-isothermal process; we omit this calculation.

The total heat added, work, and total entropy change are

$${}_1q_2 = h_2 - h_1 = \left(2875.27 \frac{\text{kJ}}{\text{kg}}\right) - \left(417.44 \frac{\text{kJ}}{\text{kg}}\right) = \boxed{2457.83 \frac{\text{kJ}}{\text{kg}}}, \quad (6.55)$$

$${}_1w_2 = P(v_2 - v_1) = (100 \text{ kPa}) \left(\left(2.17226 \frac{\text{m}^3}{\text{kg}}\right) - \left(0.001043 \frac{\text{m}^3}{\text{kg}}\right) \right) = 217.12 \frac{\text{kJ}}{\text{kg}}, \quad (6.56)$$

$$s_2 - s_1 = \left(7.8342 \frac{\text{kJ}}{\text{kg K}}\right) - \left(1.3025 \frac{\text{kJ}}{\text{kg K}}\right) = 6.5317 \frac{\text{kJ}}{\text{kg K}}. \quad (6.57)$$

Note that ${}_1w_2 \neq {}_1q_2$ because there is a change in internal energy for this process. The process is sketched in Fig. 6.10.

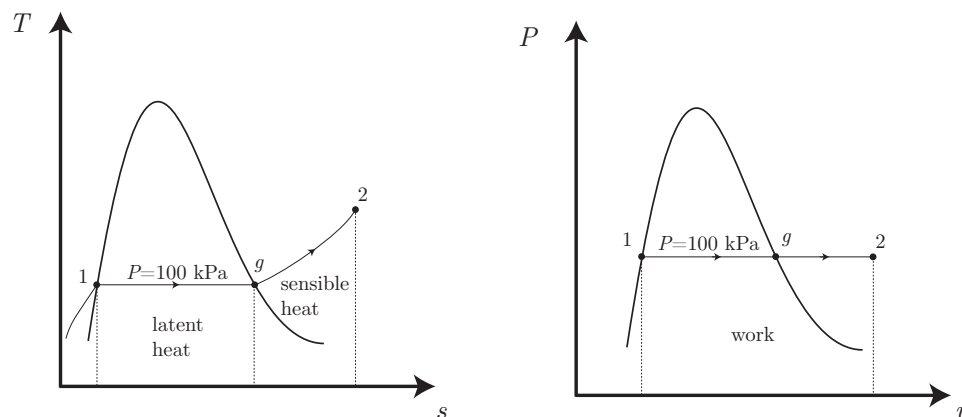

Figure 6.10: $T - s$ and $P - v$ diagrams for isobaric heating of water problem.

6.3 The Gibbs equation

We are now in a position to obtain one of the most important relations in thermodynamics, the Gibbs equation, named for the great nineteenth century American engineer, physicist, chemist, and mathematician, depicted in Fig. 6.11.

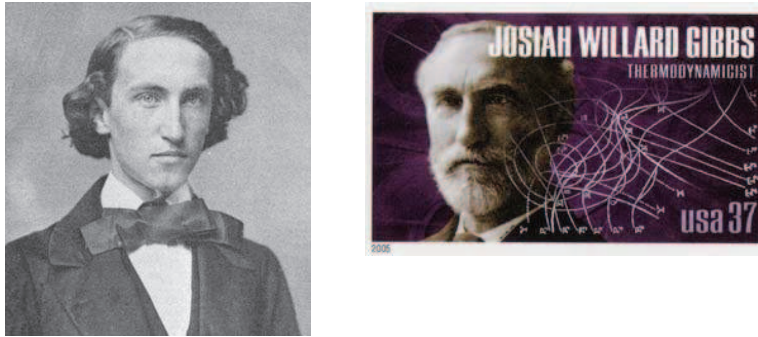

Figure 6.11: Josiah Willard Gibbs (1839-1903), American mechanical engineer who revolutionized the science of classical and statistical thermodynamics; images from <http://mathshistory.st-andrews.ac.uk/Biographies/Gibbs.html>.

The Gibbs equation is a re-capitulation of the first law of thermodynamics. It is taken in the limit that

- all processes are assumed to be reversible.

And we shall only consider the Gibbs equation for simple compressible substances, neglecting changes in kinetic and potential energy, though other forms are possible.

We first recall the differential form of the first law, Eq. (3.160), $dE = \delta Q - \delta W$, neglect⁴ changes in KE and PE , so that $dE = dU$, and then consider this on a per mass basis, obtaining

$$du = \delta q - \delta w. \quad (6.58)$$

Now, for a simple compressible substance undergoing pressure-volume work, we have Eq. (3.67) cast on a per mass basis, $\delta w = P dv$. For the same substance undergoing simultaneous reversible heat transfer, we have from Eq. (6.20), $\delta q = T ds$. So we can recast Eq. (6.58) as

⁴The justification of neglecting changes in KE and PE is rarely stated. If we retained the total energy, we would be led ultimately to $ds = de/T + (P/T) dv$. Moreover, we would conclude that changes in KE or PE could lead to a change in entropy. However, we choose to specifically retain an accounting for mechanical energy via Newton's second law. Detailed analysis of Newton's second law would show that work done by certain classes of forces, *e.g.* gravity forces and forces due to pressure differences, was reversible, and does not dissipate mechanical energy. That class of change of KE and PE should not be thought of as entropy-generating, because of its reversibility. However, work done by other types of forces, *e.g.* viscous shear forces, does dissipate mechanical energy into thermal energy. Such a conversion is irreversible, and should contribute to an entropy change. These notions are best understood in the context of the full mass, momenta, and energy equations for a continuum. Details may be found in <https://www3.nd.edu/~powers/ame.60635/notes.pdf>.

the Gibbs equation⁵:

$$\boxed{du = \underbrace{T ds}_{\delta q} - \underbrace{P dv}_{\delta w}.} \quad (6.59)$$

Gibbs presented this now famous equation in an obscure journal, that was the only journal in which he ever published. A reproduction from that journal of the page where his equation first appeared⁶ is given in Fig. 6.12.

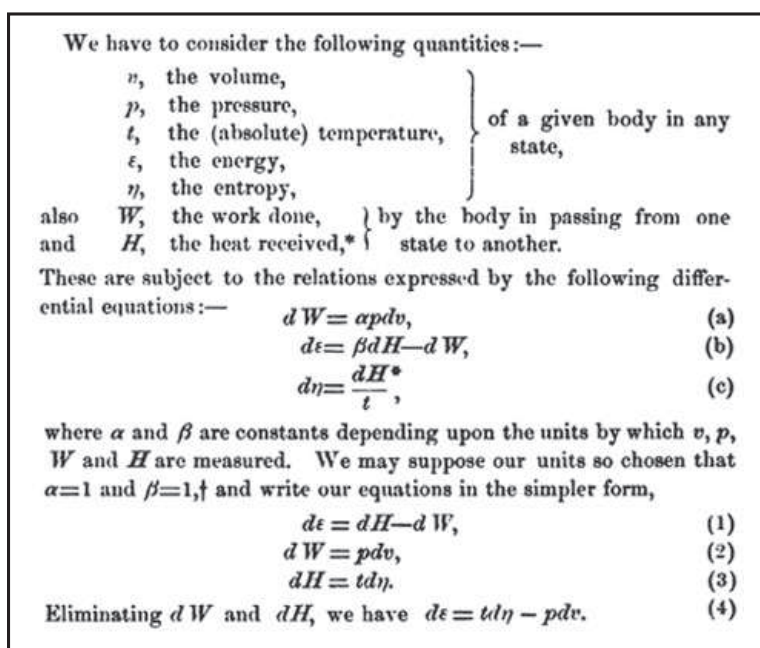

Figure 6.12: An image of the 1873 first appearance of the Gibbs equation in print.

Note that the Gibbs equation is generally valid for all materials. We have said nothing about either a thermal or caloric equation of state. It is thus valid for ideal gases, non-ideal gases, liquids, solids, or two-phase mixtures. And though we considered reversible processes in its derivation, once we have it, we note that only properties are defined, and so we do not have to restrict ourselves to reversible processes. It is commonly rearranged in a way that allows the entropy to be determined:

$$\boxed{T ds = du + P dv.} \quad (6.60)$$

⁵In this usage, similar to that given by BS, we are not alone, but may be in the minority. Some texts call Eq. (6.59) the “first Gibbs equation.” Perhaps a more common name for a variant of Eq. (6.59) is the “Fundamental Thermodynamic Relation,” that is commonly described for the extensive analog, $dU = T dS - P dV$.

⁶J. W. Gibbs, 1873, “Graphical methods in the thermodynamics of fluids,” *Transactions of the Connecticut Academy of Arts and Sciences*, 2: 309-342.

The Gibbs equation can also be written in terms of enthalpy. Recall Eq. (3.204), $h = u + Pv$, also valid for general materials. Elementary calculus then tells us

$$h = u + Pv, \quad (6.61)$$

$$dh = du + P dv + v dP, \quad (6.62)$$

$$du = dh - P dv - v dP. \quad (6.63)$$

Substitute Eq. (6.63) into the Gibbs relation Eq. (6.60) to yield

$$T ds = \underbrace{dh - P dv - v dP}_{du} + P dv, \quad (6.64)$$

$$= dh - v dP. \quad (6.65)$$

So we can say⁷

$$\boxed{dh = T ds + v dP.} \quad (6.66)$$

Example 6.5

Given the enthalpy change, calculate the entropy change for water going from saturated liquid to saturated vapor along a $T = 100^\circ\text{C}$ isotherm.

Under the vapor dome, an isotherm is an isobar, so $dP = 0$. So Eq. (6.66) reduces to

$$dh = T ds. \quad (6.67)$$

Because T is constant, the integration is easy,

$$\int_f^g dh = \int_f^g T ds, \quad (6.68)$$

$$= T \int_f^g ds, \quad (6.69)$$

$$h_g - h_f = T(s_g - s_f), \quad (6.70)$$

$$h_{fg} = T s_{fg}, \quad (6.71)$$

$$s_{fg} = \frac{h_{fg}}{T}. \quad (6.72)$$

From Table B.1.1 of BS, we find at $T = 100^\circ\text{C}$, $h_{fg} = 2257.03 \text{ kJ/kg}$. Thus, we must have

$$s_{fg} = \frac{2257.03 \frac{\text{kJ}}{\text{kg}}}{(100 + 273.15) \text{ K}} = \boxed{6.04859 \frac{\text{kJ}}{\text{kg K}}}. \quad (6.73)$$

We compare this to the value listed in BS's Table B.1.1 of $s_{fg} = 6.0480 \text{ kJ/kg/K}$. The difference is likely due to round-off errors. Note that the entropy of the vapor is greater than that of the liquid, $s_{fg} = s_g - s_f > 0$. We easily envision the vapor as having less structure or less order than the liquid.

⁷Equation (6.66) is called in some texts the “second Gibbs equation.” BS considers it to be a “Gibbs equation.”

6.4 Entropy for ideal gases

Let us find how to write the entropy for an ideal gas. We first use the Gibbs equation, Eq. (6.60), to solve for ds to get

$$ds = \frac{du}{T} + \underbrace{\frac{P}{T}}_{=R/v} dv. \quad (6.74)$$

Now, ideal gases have $Pv = RT$, so $P/T = R/v$, so we have

$$ds = \frac{du}{T} + \frac{R}{v} dv. \quad (6.75)$$

Now, ideal gases also have from Eq. (3.228), $du = c_v(T) dT$, so

$$ds = \frac{c_v(T) dT}{T} + R \frac{dv}{v}. \quad (6.76)$$

We will first consider a CPIG, and then a CIIG.

6.4.1 Calorically perfect

For a CPIG, c_v is a constant, and Eq. (6.76) reduces to

$$ds = \frac{c_v dT}{T} + R \frac{dv}{v}. \quad (6.77)$$

This is easily integrated as follows

$$\int_1^2 ds = \int_1^2 \frac{c_v dT}{T} + \int_1^2 R \frac{dv}{v}, \quad (6.78)$$

$$= c_v \int_1^2 \frac{dT}{T} + R \int_1^2 \frac{dv}{v}. \quad (6.79)$$

So we get

$$\boxed{s_2 - s_1 = c_v \ln \frac{T_2}{T_1} + R \ln \frac{v_2}{v_1}.} \quad (6.80)$$

In general for a CPIG we can say

$$\boxed{s(T, v) = s_o + c_v \ln \frac{T}{T_o} + R \ln \frac{v}{v_o},} \quad (6.81)$$

where o denotes a reference state. We can invert to solve for T/T_o as follows

$$\frac{T(s, v)}{T_o} = \left(\frac{v_o}{v}\right)^{R/c_v} \exp\left(\frac{s - s_o}{c_v}\right). \quad (6.82)$$

Because $R/c_v = (c_P - c_v)/c_v = k - 1$, we also write

$$\boxed{\frac{T(s, v)}{T_o} = \left(\frac{v_o}{v}\right)^{k-1} \exp\left(\frac{s - s_o}{c_v}\right)}. \quad (6.83)$$

Now, we can also rearrange Eq. (6.66) to get

$$ds = \frac{dh}{T} - \frac{v}{T} dP. \quad (6.84)$$

Now, the ideal gas gives us $v/T = R/P$, and the calorically perfect assumption gives us $dh = c_P dT$, with c_P a constant. Thus, Eq. (6.84) reduces to

$$ds = c_P \frac{dT}{T} - R \frac{dP}{P}. \quad (6.85)$$

We integrate Eq. (6.85) to get

$$\int_1^2 ds = c_P \int_1^2 \frac{dT}{T} - R \int_1^2 \frac{dP}{P}. \quad (6.86)$$

Thus,

$$\boxed{s_2 - s_1 = c_P \ln \frac{T_2}{T_1} - R \ln \frac{P_2}{P_1}}. \quad (6.87)$$

In general, for a CPIG we can say

$$\boxed{s(T, P) = s_o + c_P \ln \frac{T}{T_o} - R \ln \frac{P}{P_o}}, \quad (6.88)$$

where o denotes a reference state. We can invert Eq. (6.88) to form

$$\frac{T(s, P)}{T_o} = \left(\frac{P}{P_o}\right)^{R/c_P} \exp\left(\frac{s - s_o}{c_P}\right). \quad (6.89)$$

Because $R/c_P = (c_P - c_v)/c_P = 1 - 1/k = (k - 1)/k$, we have

$$\boxed{\frac{T(s, P)}{T_o} = \left(\frac{P}{P_o}\right)^{(k-1)/k} \exp\left(\frac{s - s_o}{c_P}\right)}. \quad (6.90)$$

Straightforward algebra also shows that

$$\boxed{s(P, v) = s_o + c_P \ln \frac{v}{v_o} + c_v \ln \frac{P}{P_o}}, \quad (6.91)$$

$$\boxed{Pv^k = P_o v_o^k \exp\left(\frac{s - s_o}{c_v}\right)}. \quad (6.92)$$

6.4.2 Calorically imperfect

For the CIIG, we integrate Eq. (6.76) to get

$$\int_1^2 ds = \int_1^2 \frac{c_v(T) dT}{T} + R \int_1^2 \frac{dv}{v}. \quad (6.93)$$

This gives

$$s_2 - s_1 = \int_1^2 \frac{c_v(T) dT}{T} + R \ln \frac{v_2}{v_1}. \quad (6.94)$$

For the CIIG, we have Eq. (3.230), $dh = c_p(T) dT$, along with the ideal gas result $v/T = R/P$; thus, Eq. (6.84) reduces to

$$ds = \frac{c_p(T) dT}{T} - R \frac{dP}{P}. \quad (6.95)$$

Integrating, we get

$$s_2 - s_1 = \int_1^2 \frac{c_p(T) dT}{T} - R \ln \frac{P_2}{P_1}. \quad (6.96)$$

In general we can say

$$s = s_o + \underbrace{\int_{T_o}^T \frac{c_p(\hat{T}) d\hat{T}}{\hat{T}}}_{=s_T^o} - R \ln \frac{P}{P_o}. \quad (6.97)$$

Here, the “hat” notation indicates a dummy variable of integration. Here, s_T^o is a function of temperature and represents the entropy when the pressure is evaluated at its reference value of $P = P_o$. In BS, Table A.8 gives values of s_T^o . Note that

- in this course a superscript o denotes evaluation at a reference pressure. Typically $P_o = 100$ kPa.

So for the CIIG, we have

$$s(T, P) = s_o + \underbrace{\int_{T_o}^T \frac{c_p(\hat{T}) d\hat{T}}{\hat{T}}}_{=s_T^o} - R \ln \frac{P}{P_o} = s_T^o - R \ln \frac{P}{P_o}. \quad (6.98)$$

We could also say

$$s_2 - s_1 = s_{T_2}^o - s_{T_1}^o - R \ln \frac{P_2}{P_1}. \quad (6.99)$$

Example 6.6

Consider a mass of air, $m = 10$ kg cooled isochorically from $P_1 = 1$ MPa, $T_1 = 500$ K to the temperature of the surroundings, $T_2 = 300$ K. Find the entropy change of the air, the surroundings, and the universe. Assume a CPIG model and then compare to results for a CIIG model.

The scenario is sketched in Fig. 6.13. For air, we take $R = 0.287$ kJ/kg/K, $c_v = 0.7175$ kJ/kg/K.

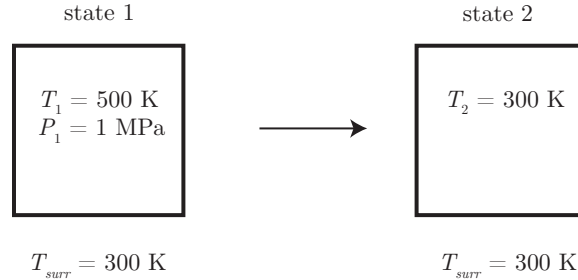

Figure 6.13: Sketch of air cooling in a large surroundings.

Thus, $c_p = R + c_v = 1.0045$ kJ/kg/K.

CPIG model

Let us consider the CPIG model. Now, $v_1 = v_2$ for the isochoric problem. The ideal gas law gives

$$\frac{P_2 v_2}{T_2} = \frac{P_1 v_1}{T_1}, \quad (6.100)$$

$$\frac{P_2 v_1}{T_2} = \frac{P_1 v_1}{T_1}, \quad (6.101)$$

$$P_2 = P_1 \frac{T_2}{T_1}, \quad (6.102)$$

$$= (1000 \text{ kPa}) \left(\frac{300 \text{ K}}{500 \text{ K}} \right), \quad (6.103)$$

$$= 600 \text{ kPa}. \quad (6.104)$$

The first law for the isochoric process tells us

$$U_2 - U_1 = {}_1Q_2 - \underbrace{{}_1W_2}_{=0}, \quad (6.105)$$

$$m c_v (T_2 - T_1) = {}_1Q_2, \quad (6.106)$$

$${}_1Q_2 = (10 \text{ kg}) \left(0.7175 \frac{\text{kJ}}{\text{kg K}} \right) ((300 \text{ K}) - (500 \text{ K})), \quad (6.107)$$

$$= -1435 \text{ kJ}. \quad (6.108)$$

The negative sign indicates the energy left the system. This is the energy that entered the surroundings.

We get the entropy change of the air via the non-specific version of Eq. (6.80):

$$S_2 - S_1 = m \left(c_v \ln \frac{T_2}{T_1} + R \ln \frac{v_2}{v_1} \right), \quad (6.109)$$

$$= (10 \text{ kg}) \left(\left(0.7175 \frac{\text{kJ}}{\text{kg K}} \right) \ln \frac{300 \text{ K}}{500 \text{ K}} + \left(0.287 \frac{\text{kJ}}{\text{kg K}} \right) \underbrace{\ln 1}_{=0} \right), \quad (6.110)$$

$$\boxed{S_2 - S_1 = -3.66517 \frac{\text{kJ}}{\text{K}}.} \quad (6.111)$$

The entropy went down for the system. Note this is consistent with $ds = \delta q/T$. When $\delta q < 0$, the entropy drops. The system becomes more ordered as it cools.

Now, the surroundings gained thermal energy, $Q = 1435 \text{ kJ}$. However, they are so massive that the surroundings' temperature remained constant. So the entropy change of the surroundings is found from

$$S_{2,surr} - S_{1,surr} = \int_1^2 \frac{\delta Q}{T_{surr}}, \quad (6.112)$$

$$= \frac{1}{T_{surr}} \int_1^2 \delta Q, \quad (6.113)$$

$$= \frac{Q_{surr}}{T_{surr}}, \quad (6.114)$$

$$= \frac{1435 \text{ kJ}}{300 \text{ K}}, \quad (6.115)$$

$$\boxed{S_{2,surr} - S_{1,surr} = 4.78333 \frac{\text{kJ}}{\text{K}}.} \quad (6.116)$$

So the energy addition to the surroundings raised its entropy.

The entropy change of the universe is that of the combination of the surroundings' change and the system's change:

$$\Delta S_{univ} = (S_{2,surr} - S_{1,surr}) + (S_2 - S_1), \quad (6.117)$$

$$= \left(4.78333 \frac{\text{kJ}}{\text{K}}\right) + \left(-3.66517 \frac{\text{kJ}}{\text{K}}\right), \quad (6.118)$$

$$\boxed{\Delta S_{univ} = 1.11816 \frac{\text{kJ}}{\text{K}}.} \quad (6.119)$$

The universe is isolated, and its entropy went up in this process, consistent with the second law of thermodynamics.

CIIG model

Let us repeat the analysis with a CIIG model. First, $P_2 = 600 \text{ kPa}$, unchanged from the CPIG model. The first law for the isochoric, work-free process gives

$${}_1Q_2 = m(u_2 - u_1). \quad (6.120)$$

But here, we use Table A.7.1 from BS to obtain the internal energies. Doing so, we get

$${}_1Q_2 = (10 \text{ kg}) \left(\left(214.36 \frac{\text{kJ}}{\text{kg}}\right) - \left(359.84 \frac{\text{kJ}}{\text{kg}}\right) \right), \quad (6.121)$$

$$= -1454.8 \text{ kJ}. \quad (6.122)$$

Note this value is very close to the CPIG prediction of -1435 kJ .

We can adapt Eq. (6.99) to calculate the entropy change of the system:

$$S_2 - S_1 = m \left(s_{T_2}^o - s_{T_1}^o - R \ln \frac{P_2}{P_1} \right). \quad (6.123)$$

Table A.7.1 from BS gives us $s_{T_2}^o = 6.86926 \text{ kJ/kg/K}$ and $s_{T_1}^o = 7.38692 \text{ kJ/kg/K}$. Thus

$$S_2 - S_1 = (10 \text{ kg}) \left(\left(6.86926 \frac{\text{kJ}}{\text{kg K}} \right) - \left(7.38692 \frac{\text{kJ}}{\text{kg K}} \right) - \left(0.287 \frac{\text{kJ}}{\text{kg K}} \right) \ln \frac{600 \text{ kPa}}{1000 \text{ kPa}} \right), \quad (6.124)$$

$$= -3.71053 \frac{\text{kJ}}{\text{K}}. \quad (6.125)$$

This is very close to the CPIG prediction of -3.66517 kJ/K .

For the entropy change of the surroundings, we get

$$S_{2,surr} - S_{1,surr} = \frac{Q_{surr}}{T_{surr}}, \quad (6.126)$$

$$= \frac{1454.8 \text{ kJ}}{300 \text{ K}}, \quad (6.127)$$

$$= 4.84933 \frac{\text{kJ}}{\text{K}}. \quad (6.128)$$

Combining the entropy changes of the surroundings and system, we get that for the universe,

$$\Delta S_{univ} = \left(4.84933 \frac{\text{kJ}}{\text{K}} \right) + \left(-3.71053 \frac{\text{kJ}}{\text{K}} \right), \quad (6.129)$$

$$= 1.1388 \frac{\text{kJ}}{\text{K}}. \quad (6.130)$$

This is very close to the CPIG estimate of 1.11816 kJ/K .

6.5 Entropy for an incompressible solid or liquid

For an incompressible solid or liquid we have $dv = 0$, so the Gibbs equation, Eq. (6.59), reduces to

$$T ds = du. \quad (6.131)$$

If we take $du = c dT$, we get

$$T ds = c dT, \quad (6.132)$$

$$ds = \frac{c dT}{T}, \quad (6.133)$$

$$s - s_o = \int_{T_o}^T \frac{c(\hat{T}) d\hat{T}}{\hat{T}}. \quad (6.134)$$

And if the solid or liquid is calorically perfect with c a true constant, we get

$$s - s_o = c \ln \frac{T}{T_o}. \quad (6.135)$$

6.6 Iso- curves

Let us use the Gibbs equation in its various forms to identify a few important curves.

6.6.1 Isochores

To identify isochores, let us consider Eq. (6.60),

$$T ds = du + P \underbrace{dv}_{=0}, \quad (6.136)$$

$$T ds = du, \quad (6.137)$$

$$T = \left. \frac{\partial u}{\partial s} \right|_v. \quad (6.138)$$

This is valid for a general material. Iff we have an ideal gas, then $du = c_v(T) dT$, and on an isochore, Eq. (6.60) becomes

$$T ds = \underbrace{du}_{=c_v(T) dT} + P \underbrace{dv}_{=0}, \quad (6.139)$$

$$T ds = c_v(T) dT, \quad (6.140)$$

$$\frac{T}{c_v(T)} = \left. \frac{\partial T}{\partial s} \right|_v. \quad (6.141)$$

Thus, the slope of an isochore in the $T - s$ plane for an ideal gas is T/c_v .

6.6.2 Isobars

To identify isobars, let us consider Eq. (6.65),

$$T ds = dh - v \underbrace{dP}_{=0}, \quad (6.142)$$

$$T ds = dh, \quad (6.143)$$

$$T = \left. \frac{\partial h}{\partial s} \right|_P. \quad (6.144)$$

This is valid for a general material. Iff we have an ideal gas, then $dh = c_P(T) dT$, and on an isobar, Eq. (6.65) becomes

$$T ds = \underbrace{dh}_{=c_P(T) dT} - v \underbrace{dP}_{=0}, \quad (6.145)$$

$$T ds = c_P(T) dT, \quad (6.146)$$

$$\frac{T}{c_P(T)} = \left. \frac{\partial T}{\partial s} \right|_P. \quad (6.147)$$

Thus, the slope of an isobar in the $T-s$ plane for an ideal gas is T/c_P . Because $c_P(T) > c_v(T)$, *the slope of the isochore is greater than the slope of an isobar at a given point.*

For air as a CPIG with $k = 7/5$, $R = 0.287$ kJ/kg/K, the scenario is sketched in Fig. 6.14. For materials such as water, the behavior is similar. The slope of the isochore is greater at

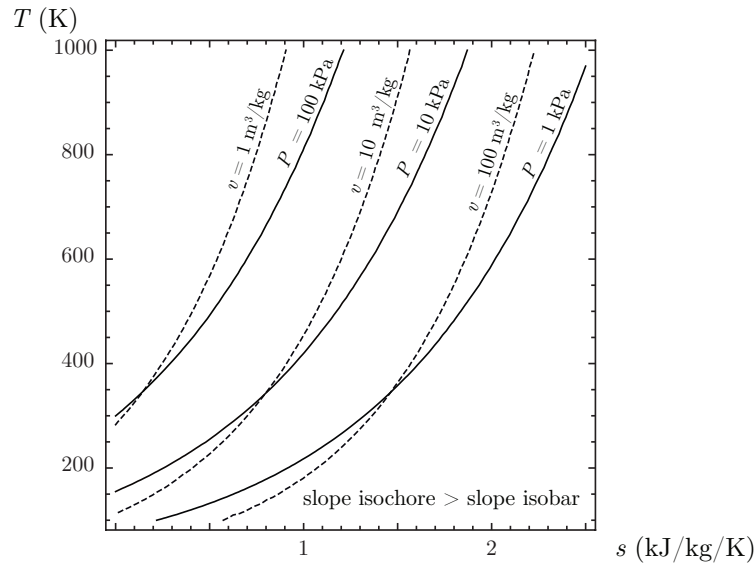

Figure 6.14: Sketch of isochores and isobars in the $T-s$ plane for CPIG air, $k = 7/5$, $R = 0.287$ kJ/kg/K, $s_o = 0$ kJ/kg/K.

a given point than that of an isobar.

6.6.3 Isentropes

We introduce an

- **ISENTROPE:** a curve on which entropy is constant.

For general materials, we identify isentropes by considering Eq. (6.60) with $ds = 0$:

$$T \underbrace{ds}_{=0} = du + P dv, \quad (6.148)$$

$$0 = du + P dv, \quad (6.149)$$

$$du = -P dv. \quad (6.150)$$

Because there is no heat transfer on an isentrope, for such a process, all of the $P dv$ work goes into changing the internal energy of the system. We could also say

$$\left. \frac{\partial u}{\partial v} \right|_s = -P. \quad (6.151)$$

Similarly,

$$T \underbrace{ds}_{=0} = dh - v dP, \quad (6.152)$$

$$0 = dh - v dP, \quad (6.153)$$

$$dh = v dP. \quad (6.154)$$

We could also say

$$\left. \frac{\partial h}{\partial P} \right|_s = v. \quad (6.155)$$

6.7 Isentropic relations for an ideal gas

Here, we will consider algebraic relations for ideal gases undergoing isentropic processes. The results are simple for CPIGs and a little more complicated for CIIGs.

6.7.1 Calorically perfect

Let us consider the important case of a CPIG undergoing an isentropic process. Start with the Gibbs equation, Eq. (6.60), $T ds = du + P dv$. Now, for an isentropic CPIG, we have $ds = 0$, $P = RT/v$, and $du = c_v dT$, so we get

$$0 = c_v dT + \frac{RT}{v} dv, \quad (6.156)$$

$$0 = c_v \frac{dT}{T} + R \frac{dv}{v}, \quad (6.157)$$

$$-c_v \frac{dT}{T} = R \frac{dv}{v}, \quad (6.158)$$

$$-c_v \int_1^2 \frac{dT}{T} = R \int_1^2 \frac{dv}{v}, \quad (6.159)$$

$$-c_v \ln \frac{T_2}{T_1} = R \ln \frac{v_2}{v_1}, \quad (6.160)$$

$$\ln \frac{T_2}{T_1} = \frac{R}{c_v} \ln \frac{v_1}{v_2}, \quad (6.161)$$

$$= \ln \left(\frac{v_1}{v_2} \right)^{R/c_v}, \quad (6.162)$$

$$= \ln \left(\frac{v_1}{v_2} \right)^{k-1}, \quad (6.163)$$

$$\frac{T_2}{T_1} = \left(\frac{v_1}{v_2} \right)^{k-1}. \quad (6.164)$$

Now, because $T = Pv/R$, we can also say

$$\frac{\frac{P_2 v_2}{R}}{\frac{P_1 v_1}{R}} = \left(\frac{v_1}{v_2}\right)^{k-1}, \quad (6.165)$$

$$\frac{P_2 v_2}{P_1 v_1} = \left(\frac{v_1}{v_2}\right)^{k-1}, \quad (6.166)$$

$$\frac{P_2}{P_1} = \left(\frac{v_1}{v_2}\right)^k, \quad (6.167)$$

$$\left(\frac{P_2}{P_1}\right)^{\frac{k-1}{k}} = \left(\frac{v_1}{v_2}\right)^{k-1}. \quad (6.168)$$

We can summarize by combining Eqs. (6.164, 6.168) to get an important result, that we emphasize *is valid for isentropic calorically perfect ideal gases only*:

$$\boxed{\frac{T_2}{T_1} = \left(\frac{P_2}{P_1}\right)^{\frac{k-1}{k}} = \left(\frac{v_1}{v_2}\right)^{k-1}}. \quad (6.169)$$

Another useful form is given by rearranging Eq. (6.168) to get the result, again *valid for isentropic calorically perfect ideal gases only*:

$$\boxed{P_1 v_1^k = P_2 v_2^k}. \quad (6.170)$$

We see that the isentropic relation between P and v is that for a polytropic process, see p. 94, with the polytropic exponent $n = k$. Recall for an ideal gas undergoing an isothermal process, we have $P_1 v_1 = P_2 v_2$, that is polytropic with $n = 1$.

Example 6.7

Compare the slope of an isentrope and isotherm through the same point in the $P - v$ plane for a CPIG.

For an isotherm in the $P - v$ plane for a CPIG, we can say

$$Pv = P_o v_o, \quad (6.171)$$

$$P = P_o v_o \frac{1}{v}, \quad (6.172)$$

$$\left. \frac{\partial P}{\partial v} \right|_T = -P_o v_o \frac{1}{v^2}, \quad (6.173)$$

$$\boxed{\left. \frac{\partial P}{\partial v} \right|_{T=v=v_o} = -\frac{P_o}{v_o}}. \quad (6.174)$$

For an isentrope in the $P - v$ plane for a CPIG, we can say

$$Pv^k = P_o v_o^k, \quad (6.175)$$

$$P = P_o v_o^k \frac{1}{v^k}, \quad (6.176)$$

$$\left. \frac{\partial P}{\partial v} \right|_s = -k P_o v_o^k \frac{1}{v^{1+k}}, \quad (6.177)$$

$$\boxed{\left. \frac{\partial P}{\partial v} \right|_{s, v=v_o} = -k \frac{P_o}{v_o}.} \quad (6.178)$$

Both slopes are negative, because $P_o > 0$ and $v_o > 0$. Because $k > 1$, the magnitude of the isentrope's slope is steeper than that of the isotherm. We give a sketch of the behavior of an isentrope and isotherm for a CPIG, each passing through the point (P_o, v_o) in the (P, v) plane, in Fig. 6.15.

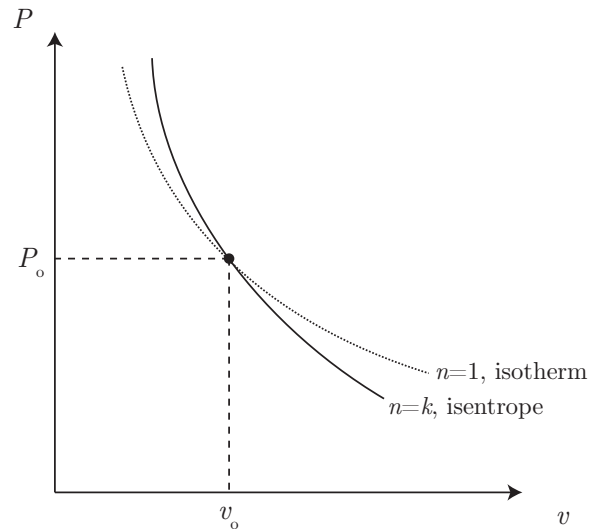

Figure 6.15: Sketch of isentrope and isotherm for a CPIG in the $P - v$ plane.

Example 6.8

Show that dT/dz is constant in an isentropic atmosphere, and give an estimate for it.

We must consider the forces acting on a differential slice of the atmosphere. Consider the free body diagram in Fig. 6.16. Newton's second law for the fluid gives rise to

$$\underbrace{\rho A dz \frac{d^2 z}{dt^2}}_{=0} = PA - (P + dP)A - \rho g A dz. \quad (6.179)$$

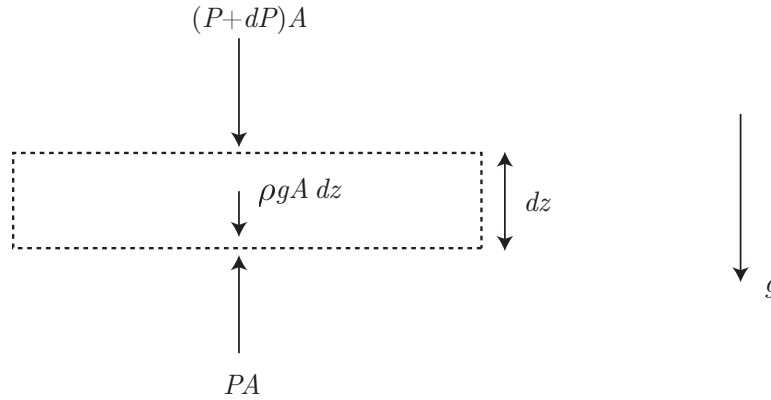

Figure 6.16: Free body diagram for differential slice of the atmosphere.

For an atmosphere in mechanical equilibrium, we neglect fluid acceleration and arrive at a force balance of surface forces against the weight of the fluid:

$$PA = (P + dP)A + \rho g A dz, \quad (6.180)$$

$$= PA + A dP + \rho g A dz, \quad (6.181)$$

$$0 = A dP + \rho g A dz, \quad (6.182)$$

$$= dP + \rho g dz, \quad (6.183)$$

$$\frac{dP}{dz} = -\rho g. \quad (6.184)$$

As $\rho > 0$ and $g > 0$, we see that the pressure gradient $dP/dz < 0$. That is, the pressure goes down as we go up in height. If the density were constant, as it would be for liquid water, we could easily integrate this to get a linear relationship between P and z . In fact we did assume constant density in an earlier analysis, which led to the simple Eq. (1.65), $\Delta P = \rho g H$. However, for air, ρ is not constant; it too varies with z . So a more complicated analysis is required.

Let us eliminate both P and ρ from Eq. (6.184) in favor of T because we are seeking to show dT/dz is a constant. Let us first impose the CPIG assumption. Thus

$$P = \rho RT. \quad (6.185)$$

Now, let us invoke an isentropic relation for a CPIG. From Eq. (6.169), we can easily deduce that

$$P = P_o \left(\frac{T}{T_o} \right)^{\frac{k}{k-1}}. \quad (6.186)$$

Now, take d/dz of Eq. (6.186), using the chain rule, to get

$$\frac{dP}{dz} = \frac{P_o}{T_o} \frac{k}{k-1} \left(\frac{T}{T_o} \right)^{\frac{k}{k-1}-1} \frac{dT}{dz}. \quad (6.187)$$

Now, use Eq. (6.185) to eliminate ρ in Eq. (6.184) and use Eq. (6.187) to eliminate dP/dz in Eq. (6.184), yielding

$$\underbrace{\frac{P_o}{T_o} \frac{k}{k-1} \left(\frac{T}{T_o} \right)^{\frac{1}{k-1}} \frac{dT}{dz}}_{dP/dz} = - \underbrace{\frac{P}{RT}}_{\rho} g. \quad (6.188)$$

Now, use Eq. (6.186) to eliminate P to get

$$\frac{P_o}{T_o} \frac{k}{k-1} \left(\frac{T}{T_o}\right)^{\frac{1}{k-1}} \frac{dT}{dz} = -\frac{P_o \left(\frac{T}{T_o}\right)^{\frac{k}{k-1}}}{RT} g, \quad (6.189)$$

$$\frac{k}{k-1} \left(\frac{T}{T_o}\right)^{\frac{1}{k-1}} \frac{dT}{dz} = -\frac{\left(\frac{T}{T_o}\right)^{\frac{k}{k-1}}}{R \frac{T}{T_o}} g, \quad (6.190)$$

$$= -\frac{\left(\frac{T}{T_o}\right)^{\frac{1}{k-1}}}{R} g, \quad (6.191)$$

$$\frac{dT}{dz} = -\frac{k-1}{k} \frac{g}{R}, \quad (6.192)$$

$$= -\frac{\frac{c_P}{c_v} - 1}{\frac{c_P}{c_v}} \frac{g}{c_P - c_v}, \quad (6.193)$$

$$= -\frac{g}{c_P}. \quad (6.194)$$

So dT/dz is indeed a constant. Let us use numerical values to estimate the gradient:

$$\frac{dT}{dz} = -\frac{9.81 \frac{\text{m}}{\text{s}^2}}{1004.5 \frac{\text{J}}{\text{kg K}}} = -0.009766 \frac{\text{K}}{\text{m}} = -9.766 \frac{\text{K}}{\text{km}}. \quad (6.195)$$

Commercial airplanes fly around at altitude near 10 km. So we might expect temperatures at this altitude to be about 100 K less than on the ground with this simple estimate. Mountain climbers of Denali have to rise 5.5 km from its base to its peak; thus, they might expect to experience a 53 K temperature drop during the ascent, that is a drop of roughly 95 °F. Climbers of Pike's Peak have only a 1.6 km rise, and so can expect at 15 K (27 °F) drop. There are other mitigating effects that can modulate these temperature changes that we have not included.

The predictions of Eq. (6.195) are compared to data for a standard atmosphere from Kuethe and Chow⁸ in Fig. 6.17. Obviously, the theory and data have some mismatch. For $z < 10000$ m, the slopes of the curves are different, with our theory predicting a drop of roughly 10 K/km. The observed rate of drop in this region is linear but at a rate of 6.5 K/km. Kundu and Cohen⁹ attribute the discrepancy to the neglect of the influence of moisture in the air in the atmosphere. For $z > 10000$ m, the difference becomes more pronounced. At this stage, we have reached the end of the troposphere and entered the stratosphere, where different physics are at work. The predictions of an adiabatic theory for pressure variation with altitude compare what better to the data as shown in Fig. 6.18.

Example 6.9

We are given a cylinder divided by a frictionless, mobile, adiabatic piston, with air on one side and water on the other side as shown in Fig. 6.19. The air is thermally insulated from the water

⁸A. M. Kuethe and C.-Y. Chow, 1998, *Foundations of Aerodynamics*, Fifth Edition, John Wiley, New York, p. 533.

⁹P. K. Kundu and I. M. Cohen, 2008, *Fluid Mechanics*, Fourth Edition, Academic Press, Amsterdam, p. 605.

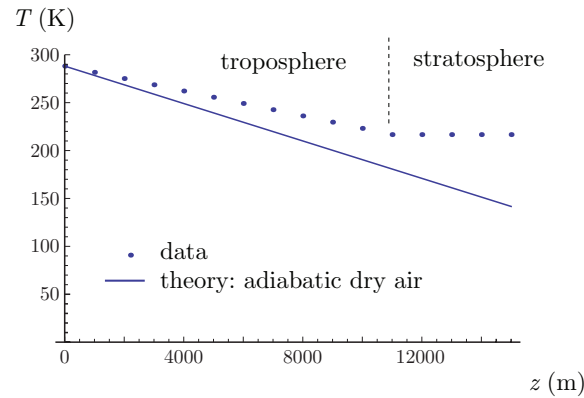

Figure 6.17: Atmospheric temperature as a function of altitude: predictions of Eq. (6.195) compared with data from Kuethe and Chow.

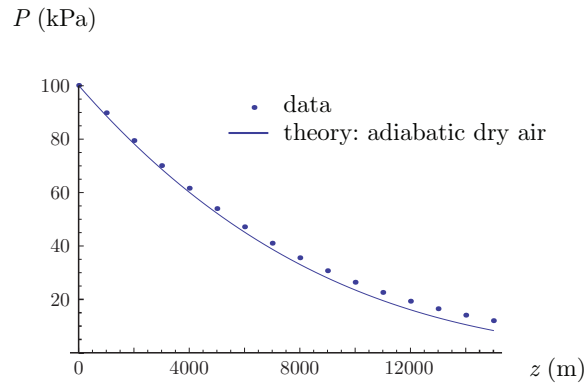

Figure 6.18: Atmospheric pressure as a function of altitude: predictions of an adiabatic theory compared with data from Kuethe and Chow.

and the surroundings. The water is in thermal contact with its surroundings. Initially $V_{a1} = 0.1 \text{ m}^3$, $V_{w1} = 0.1 \text{ m}^3$, $T_{a1} = 40 \text{ }^\circ\text{C}$, $T_{w1} = 90 \text{ }^\circ\text{C}$, $x_{w1} = 0.1$, where a stands for air and w for water. Heat is added until $x_{w2} = 1$. Find the final pressure and the heat added.

Because the piston is frictionless and mobile, we can say at all times that the air and water are in mechanical equilibrium:

$$P_a = P_w. \quad (6.196)$$

The pressure will vary throughout the process, but air and water will always have the same pressure. We also can see that the total volume will be constant:

$$V_a + V_w = 0.2 \text{ m}^3. \quad (6.197)$$

Now, the air undergoes a reversible adiabatic process, i.e. isentropic. The water undergoes a non-adiabatic process; hence, it is not isentropic.

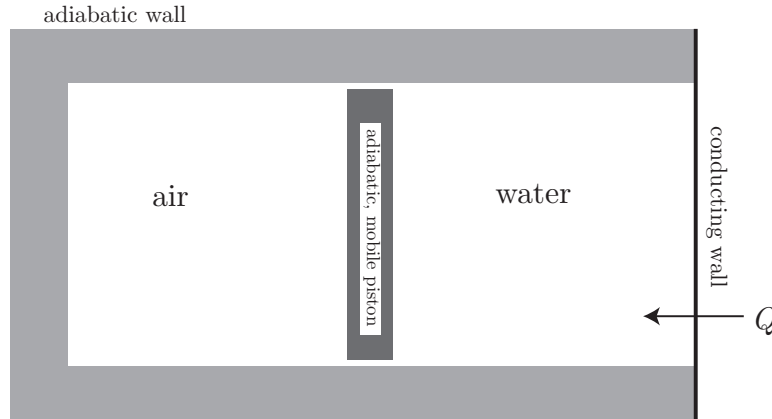

Figure 6.19: Schematic of piston-cylinder arrangement with air on one side and water on the other.

At the initial state the water is saturated at 90°C , $x = 0.1$. We learn from the tables that

$$P_{w1} = 70.14 \text{ kPa}, \quad (6.198)$$

$$v_{w1} = v_f + x_1 v_{fg}, \quad (6.199)$$

$$= \left(0.001036 \frac{\text{m}^3}{\text{kg}}\right) + (0.1) \left(2.35953 \frac{\text{m}^3}{\text{kg}}\right), \quad (6.200)$$

$$= 0.2370 \frac{\text{m}^3}{\text{kg}}, \quad (6.201)$$

$$u_{w1} = u_f + x_1 u_{fg}, \quad (6.202)$$

$$= \left(376.85 \frac{\text{kJ}}{\text{kg}}\right) + (0.1) \left(2117.7 \frac{\text{kJ}}{\text{kg}}\right), \quad (6.203)$$

$$= 588.62 \frac{\text{kJ}}{\text{kg}}, \quad (6.204)$$

$$s_{w1} = s_f + x_1 s_{fg}, \quad (6.205)$$

$$= \left(1.1925 \frac{\text{kJ}}{\text{kg K}}\right) + (0.1) \left(6.2866 \frac{\text{kJ}}{\text{kg K}}\right), \quad (6.206)$$

$$= 1.8212 \frac{\text{kJ}}{\text{kg K}}. \quad (6.207)$$

Now, we can find the mass of the water via

$$m_w = \frac{V_{w1}}{v_{w1}} = \frac{0.1 \text{ m}^3}{0.2370 \frac{\text{m}^3}{\text{kg}}} = 0.4219 \text{ kg}. \quad (6.208)$$

Now, because of pressure equilibrium,

$$P_{a1} = P_{w1} = 70.14 \text{ kPa}. \quad (6.209)$$

From the ideal gas law,

$$v_{a1} = \frac{RT_{a1}}{P_{a1}} = \frac{\left(0.287 \frac{\text{kJ}}{\text{kg K}}\right) (40 + 273) \text{ K}}{70.14 \text{ kPa}} = 1.281 \frac{\text{m}^3}{\text{kg}}. \quad (6.210)$$

| P_w (kPa) | $v_g \frac{\text{m}^3}{\text{kg}}$ | $RHS \frac{\text{m}^3}{\text{kg}}$ |
|-------------|------------------------------------|------------------------------------|
| 100 | 1.6940 | 0.5923 |
| 300 | 0.6058 | 0.0910 |
| 400 | 0.4625 | 0.0240 |
| 450 | 0.4140 | 0.0011 |
| 453 | 0.4133 | 0.0008 |
| 500 | 0.3749 | -0.0172 |

Table 6.1: Iteration results for water-air problem.

So the mass of the air is

$$m_a = \frac{V_{A1}}{v_{a1}} = \frac{0.1 \text{ m}^3}{1.281 \frac{\text{m}^3}{\text{kg}}} = 0.07808 \text{ kg}. \quad (6.211)$$

Now, for the isentropic process for the air, we have

$$P_{a1} V_{a1}^k = P_{a2} V_{a2}^k, \quad (6.212)$$

$$V_{a2} = V_{a1} \left(\frac{P_{a1}}{P_{a2}} \right)^{1/k}. \quad (6.213)$$

Now, at state 2, Eq. (6.197) gives $V_{a2} + V_{w2} = 0.2 \text{ m}^3$. Substitute Eq. (6.213) into this and eliminate V_{w2} in favor of mass and specific volume to get

$$V_{a1} \underbrace{\left(\frac{P_{a1}}{P_{a2}} \right)^{1/k}}_{=V_{a2}} + \underbrace{m_w v_{w2}}_{=V_{w2}} = 0.2 \text{ m}^3. \quad (6.214)$$

Next use $P_a = P_w$ to get

$$V_{a1} \left(\frac{P_{w1}}{P_{w2}} \right)^{1/k} + m_w v_{w2} = 0.2 \text{ m}^3. \quad (6.215)$$

Substitute numbers we know to get

$$(0.1 \text{ m}^3) \left(\frac{70.14 \text{ kPa}}{P_{w2}} \right)^{1/1.4} + (0.4219 \text{ kg}) v_{w2} - 0.2 \text{ m}^3 = 0. \quad (6.216)$$

Now, this is a relation between P_{w2} and v_{w2} . It is not sufficient to fix the state. However, we know $x_2 = 1$. This gives us another curve in the $P - v$ space. Let us guess a value of P_{w2} , read the value of v_g from the tables, substitute both into Eq. (6.216), see how close the right hand side (RHS) comes to zero, and iterate until we have an acceptable estimate. We generate Table 6.1. After the iteration, we see that

$$P_{w2} = P_{a2} = 453 \text{ kPa}, \quad v_{w2} = 0.4133 \frac{\text{m}^3}{\text{kg}}. \quad (6.217)$$

The tables then give

$$T_{w2} = 148 \text{ }^\circ\text{C}, \quad s_{w2} = 6.856 \frac{\text{kJ}}{\text{kg K}}, \quad u_{w2} = 2557.7 \frac{\text{kJ}}{\text{kg}}. \quad (6.218)$$

Now

$$V_{w2} = m_w v_{w2} = (0.4219 \text{ kg}) \left(0.4133 \frac{\text{m}^3}{\text{kg}} \right) = 0.1744 \text{ m}^3. \quad (6.219)$$

Thus,

$$V_{a2} = (0.2 \text{ m}^3) - V_{w2} = (0.2 \text{ m}^3) - (0.1744 \text{ m}^3) = 0.0256 \text{ m}^3. \quad (6.220)$$

Thus,

$$v_{a2} = \frac{V_{a2}}{m_a} = \frac{0.0256 \text{ m}^3}{0.07808 \text{ kg}} = 0.3282 \frac{\text{m}^3}{\text{kg}}. \quad (6.221)$$

Now, we know two properties of the air, so we can get

$$T_{a2} = \frac{P_{a2} v_{a2}}{R} = \frac{(453 \text{ kPa}) \left(0.3282 \frac{\text{m}^3}{\text{kg}} \right)}{0.287 \frac{\text{kJ}}{\text{kg K}}} = 518.1 \text{ K}. \quad (6.222)$$

Now, consider the first law of thermodynamics for the entire system. The work is zero because the entire system is isochoric. So the first law gives

$$U_2 - U_1 = {}_1Q_2 - \underbrace{{}_1W_2}_{=0}, \quad (6.223)$$

$${}_1Q_2 = m_a c_v (T_{a2} - T_{a1}) + m_w (u_{w2} - u_{w1}), \quad (6.224)$$

$$\begin{aligned} &= (0.07808 \text{ kg}) \left(0.7175 \frac{\text{kJ}}{\text{kg K}} \right) ((518.1 \text{ K}) - (313 \text{ K})) \\ &+ (0.4219 \text{ kg}) \left(\left(2557.7 \frac{\text{kJ}}{\text{kg}} \right) - \left(588.62 \frac{\text{kJ}}{\text{kg}} \right) \right), \end{aligned} \quad (6.225)$$

$$\boxed{{}_1Q_2 = 842.2 \text{ kJ.}} \quad (6.226)$$

Let us keep on analyzing! Consider the air alone, that is adiabatic. The first law for the air alone says

$$U_{a2} - U_{a1} = \underbrace{{}_{a1}Q_{a2}}_{=0} - {}_{a1}W_{a2}, \quad (6.227)$$

$${}_{a1}W_{a2} = -(U_{a2} - U_{a1}), \quad (6.228)$$

$$= m_a c_v (T_{a1} - T_{a2}), \quad (6.229)$$

$$= (0.07808 \text{ kg}) \left(0.7175 \frac{\text{kJ}}{\text{kg K}} \right) ((313 \text{ K}) - (518.1 \text{ K})), \quad (6.230)$$

$$= -11.49 \text{ kJ}. \quad (6.231)$$

The work is negative as the air was compressed.

Let us calculate the entropy changes. For the combined system, we have

$$\Delta S_{system} = \underbrace{\Delta S_a}_{=0} + \Delta S_w, \quad (6.232)$$

$$= m_w (s_{w2} - s_{w1}), \quad (6.233)$$

$$= (0.4219 \text{ kg}) \left(\left(6.856 \frac{\text{kJ}}{\text{kg K}} \right) - \left(1.8212 \frac{\text{kJ}}{\text{kg K}} \right) \right), \quad (6.234)$$

$$= 2.124 \frac{\text{kJ}}{\text{K}}. \quad (6.235)$$

Now, in order for the process to occur, the surroundings must at least have been $T_{surr} = 148\text{ }^\circ\text{C} = 421\text{ K}$. The surroundings must have had $Q = -842.2\text{ kJ}$, so their entropy change was

$$\Delta S_{surr} = \frac{Q}{T_{surr}} = \frac{-842.2\text{ kJ}}{421\text{ K}} = -2.00\frac{\text{kJ}}{\text{K}}. \quad (6.236)$$

So the entropy change of the universe is

$$\Delta S_{univ} = \Delta S_{sys} + \Delta S_{surr} = \left(2.124\frac{\text{kJ}}{\text{K}}\right) + \left(-2.00\frac{\text{kJ}}{\text{K}}\right) = 0.124\frac{\text{kJ}}{\text{K}}. \quad (6.237)$$

Example 6.10

Consider the cannon shown in Fig. 6.20. At $t = 0\text{ s}$, the bore of the cannon between the projectile

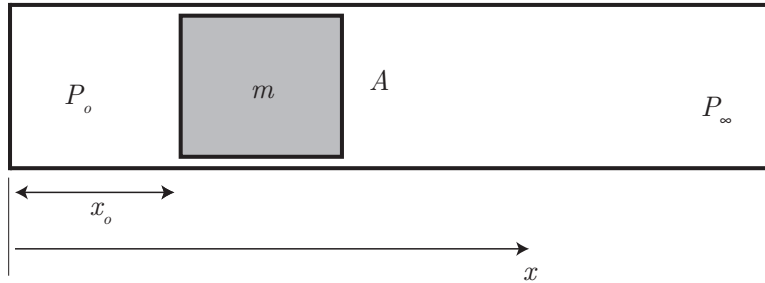

Figure 6.20: Sketch of cannon.

and its base is filled with a CPIG at P_o . The projectile is located at $x = x_o$. The projectile fits snugly in the cannon, has mass m , and cross-sectional area A . The ambient pressure is P_∞ . Find the equations of motion for the projectile. Assume the gas expands isentropically, and the local pressure is P . Assume a drag force, proportional to the cube of projectile velocity, retards its motion.

This is a problem that is not in mechanical equilibrium. Newton's law of motion for the projectile states

$$m\frac{d^2x}{dt^2} = (P - P_\infty)A - C\left(\frac{dx}{dt}\right)^3. \quad (6.238)$$

Here, the product of mass and acceleration is balanced by the net pressure force and the drag force. Let us define the velocity as

$$v = \frac{dx}{dt}. \quad (6.239)$$

So our equation of motion becomes

$$m\frac{dv}{dt} = (P - P_\infty)A - Cv^3. \quad (6.240)$$

Now, for an isentropic expansion of a CPIG we have

$$P_o V_o^k = P V^k, \quad (6.241)$$

$$P_o (A x_o)^k = P (A x)^k, \quad (6.242)$$

$$P = P_o \left(\frac{x_o}{x} \right)^k. \quad (6.243)$$

Thus, we can say

$$m \frac{dv}{dt} = \left(P_o \left(\frac{x_o}{x} \right)^k - P_\infty \right) A - C v^3. \quad (6.244)$$

We can thus form a system of two non-linear ordinary differential equations:

$$\frac{dv}{dt} = \frac{P_\infty A}{m} \left(\frac{P_o}{P_\infty} \left(\frac{x_o}{x} \right)^k - 1 \right) - \frac{C}{m} v^3, \quad v(0) = 0, \quad (6.245)$$

$$\frac{dx}{dt} = v, \quad x(0) = x_o. \quad (6.246)$$

For general parameters, an analytic solution is unlikely. However, we can form a numerical solution. Our equations are of the form

$$\frac{dv}{dt} = f(v, x), \quad v(0) = 0, \quad (6.247)$$

$$\frac{dx}{dt} = g(v, x), \quad x(0) = x_o. \quad (6.248)$$

We can use a finite difference method, here the first order explicit Euler method, to discretize these equations as

$$\frac{v_{n+1} - v_n}{\Delta t} = f(v_n, x_n), \quad (6.249)$$

$$\frac{x_{n+1} - x_n}{\Delta t} = g(v_n, x_n). \quad (6.250)$$

Here, n represents an old value and $n + 1$ represents a new value. We solve for the new to obtain

$$v_{n+1} = v_n + \Delta t f(v_n, x_n), \quad (6.251)$$

$$x_{n+1} = x_n + \Delta t g(v_n, x_n). \quad (6.252)$$

We start with known values of v_n and x_n . We use the above formulæ to get new values, then we repeat the process as long as necessary until we have a full solution. When we choose Δt sufficiently small, we should get a stable solution that is a good approximation of the actual solution. Linearization near the equilibrium point gives an estimate for Δt :

$$\Delta t < \sqrt{\frac{m x_o}{k P_o A} \left(\frac{P_o}{P_\infty} \right)^{\frac{1+k}{k}}}. \quad (6.253)$$

This estimate is only valid in the limit as $t \rightarrow \infty$, and so may not work for early time, where Δt may need to be much smaller. For early time, we can linearize near the initial point and find that we need

$$\Delta t < \sqrt{\frac{m x_o}{k P_o A}}, \quad (6.254)$$

to capture the early time dynamics.

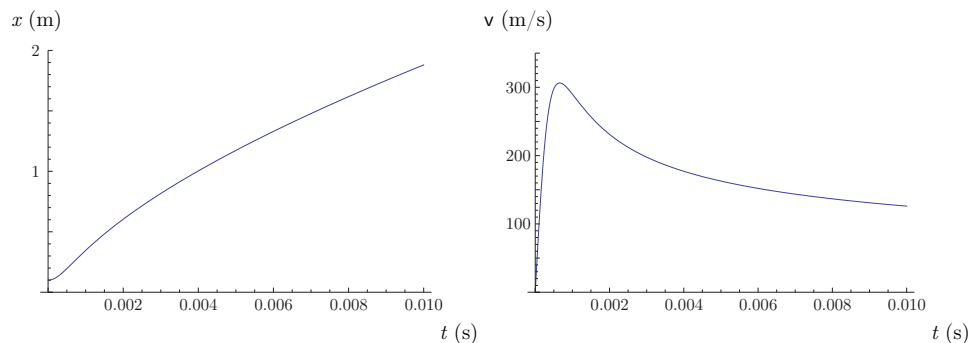

Figure 6.21: Position and velocity of projectile in cannon problem for early time.

For $m = 1$ kg, $A = 0.01$ m², $C = 0.01$ N/(m/s)³, $P_\infty = 10^5$ Pa, $P_o = 10^8$ Pa, $x_o = 0.1$ m, $k = 7/5$, we have obtained a numerical solution. Note that at such a high pressure, not unlike those in real cannons, the ideal gas law is likely not an accurate assumption.

A plot at early time for $x(t)$ and $v(t)$ is given in Fig. 6.21. This shows a window in time that is consistent with a realistic barrel length. For these values, our estimate, Eq. (6.254), for the time step to capture the early time dynamics gives $\Delta t < 2.6 \times 10^{-4}$ s. Note this is consistent with the rise time results shown in Fig. 6.21 that show the peak velocity of near 300 m/s reached in under 0.001 s. These muzzle velocities are a little low for actual cannons, that also may have higher initial pressures. Around $t = 0.01$ s, we have $x \sim 2$ m, that is not unlike a cannon barrel length.

Let us now assume an unrealistically long barrel length and calculate for a long time. A plot at late time for $x(t)$ and $v(t)$ is given in Fig. 6.22. At late time we see the projectile is approaching an

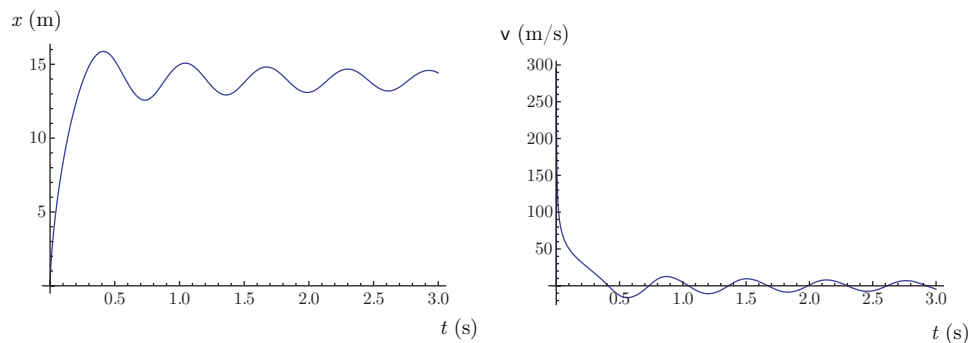

Figure 6.22: Position and velocity of projectile in cannon problem for late time.

equilibrium where the velocity goes to zero due to drag forces and the position oscillates about an equilibrium where there is a pressure balance. As $t \rightarrow \infty$, our estimate, Eq. (6.253) for Δt is applicable. For these values, our estimate for the time step near equilibrium, Eq. (6.253), gives $\Delta t < 0.10$ s. This time scale actually captures the period of oscillation effectively. It is surprising that the system came to equilibrium at such a short distance $x = 15$ m, and it is hard to imagine an actual artillery shell behaving in this way. It is likely that the drag model is highly inaccurate.

A clearer picture of the early, intermediate, and late time dynamics can be seen in the log-log scale plot of $x(t)$ given in Fig. 6.23. For early time $t < 10^{-4}$ s, the piston is effectively stationary. We call this a time of *inertial confinement*. For $t > 10^{-4}$ s, we see that x grows exponentially as time grows, reflected in the positive sloped line on the log-log plot of Fig. 6.23. During this phase of the expansion,

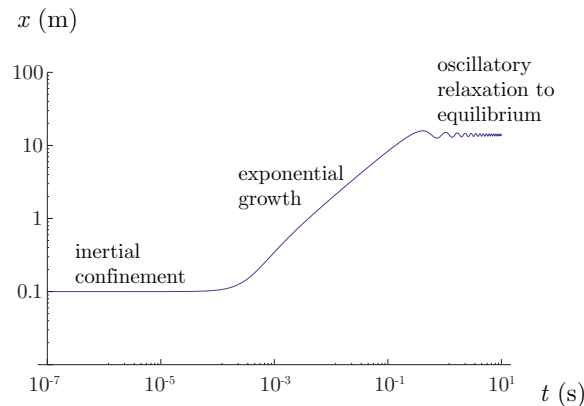

Figure 6.23: Position of projectile in cannon problem versus time, plotted on a log-log scale to reveal the regimes where different physics are dominant.

the pressure force of the compressed air dominates the resistive force of the atmospheric pressure and the drag force. As x rises, and as dx/dt rises, the resistance of the atmosphere and the drag force both become more prominent, until around $t \sim 1$ s, when the forces begin to balance one another. At this point, there is overcompensation due to the inertia of the piston, and the atmospheric pressure dominates the charge pressure. This sets up an oscillation, that ultimately decays due to the drag force.

Example 6.11

For the previous example problem, show details of the linearized analysis in the late time limit so as to derive Eqs. (6.253).

At equilibrium, we must have $dv/dt = 0$ and $dx/dt = 0$. So, as with all equilibrium states, we solve the corresponding *algebra* problem deduced from Eqs. (6.245), 6.246):

$$0 = \frac{P_\infty A}{m} \left(\frac{P_o}{P_\infty} \left(\frac{x_o}{x_{eq}} \right)^k - 1 \right) - \frac{C}{m} v_{eq}^3, \quad (6.255)$$

$$0 = v_{eq}. \quad (6.256)$$

Equations (6.255, 6.256) form two algebraic equations for the two unknowns v_{eq} and x_{eq} at the equilibrium state. One root is obvious, and the other is easily found with simple algebra. The equilibrium state is thus seen to be

$$x_{eq} = x_o \left(\frac{P_o}{P_\infty} \right)^{\frac{1}{k}}, \quad (6.257)$$

$$v_{eq} = 0. \quad (6.258)$$

Note

- The equilibrium state is one of rest, $v_{eq} = 0$. This is consistent with a mechanical equilibrium.

- x_{eq} rises if x_o increases, P_o increases, or P_∞ decreases.
- The equilibrium state is independent of the mass of the projectile, and the cross-sectional area.

Now, let us examine the local *dynamics* in the neighborhood of equilibrium. Consider Taylor series expansions about x_{eq} and v_{eq} of Eqs. (6.247, 6.248):

$$\frac{dv}{dt} = \underbrace{f(v_{eq}, x_{eq})}_{=0} + \left. \frac{\partial f}{\partial v} \right|_{eq} (v - v_{eq}) + \left. \frac{\partial f}{\partial x} \right|_{eq} (x - x_{eq}) + \dots, \quad (6.259)$$

$$\frac{dx}{dt} = \underbrace{g(v_{eq}, x_{eq})}_{=0} + \left. \frac{\partial g}{\partial v} \right|_{eq} (v - v_{eq}) + \left. \frac{\partial g}{\partial x} \right|_{eq} (x - x_{eq}) + \dots \quad (6.260)$$

We have constructed f and g to have values of zero at equilibrium. Now, because v_{eq} and x_{eq} are constants with derivatives of zero, we can rewrite Eqs. (6.259, 6.260) as

$$\frac{d}{dt}(v - v_{eq}) = \left. \frac{\partial f}{\partial v} \right|_{eq} (v - v_{eq}) + \left. \frac{\partial f}{\partial x} \right|_{eq} (x - x_{eq}) + \dots, \quad (6.261)$$

$$\frac{d}{dt}(x - x_{eq}) = \left. \frac{\partial g}{\partial v} \right|_{eq} (v - v_{eq}) + \left. \frac{\partial g}{\partial x} \right|_{eq} (x - x_{eq}) + \dots \quad (6.262)$$

Now, with

$$f(v, x) = \frac{P_\infty A}{m} \left(\frac{P_o}{P_\infty} \left(\frac{x_o}{x} \right)^k - 1 \right) - \frac{C}{m} v^3, \quad (6.263)$$

We have

$$\frac{\partial f}{\partial v} = -3 \frac{C}{m} v^2. \quad (6.264)$$

At equilibrium, where $v = 0$, this gives

$$\left. \frac{\partial f}{\partial v} \right|_{eq} = 0. \quad (6.265)$$

We also get

$$\frac{\partial f}{\partial x} = -k \frac{P_o A}{m x} \left(\frac{x_o}{x} \right)^k. \quad (6.266)$$

Evaluating $\partial f / \partial x$ at the equilibrium point, we find

$$\left. \frac{\partial f}{\partial x} \right|_{eq} = -k \frac{P_o A}{m x_o} \left(\frac{P_\infty}{P_o} \right)^{\frac{1+k}{k}}. \quad (6.267)$$

By inspection, we see that $\partial g / \partial v = 1$ and $\partial g / \partial x = 0$. Thus, Eqs. (6.261, 6.262) become

$$\frac{d}{dt}(v - v_{eq}) = -k \frac{P_o A}{m x_o} \left(\frac{P_\infty}{P_o} \right)^{\frac{1+k}{k}} (x - x_{eq}) + \dots, \quad (6.268)$$

$$\frac{d}{dt}(x - x_{eq}) = (v - v_{eq}) + \dots \quad (6.269)$$

Let us define two new variables:

$$\hat{x}(t) = x(t) - x_{eq}, \quad (6.270)$$

$$\hat{v}(t) = v(t) - v_{eq}. \quad (6.271)$$

With the definitions of Eqs. (6.270, 6.271), Eqs. (6.268, 6.269) reduce to

$$\frac{d\hat{v}}{dt} = -k \frac{P_o A}{m x_o} \left(\frac{P_\infty}{P_o} \right)^{\frac{1+k}{k}} \hat{x}, \quad (6.272)$$

$$\frac{d\hat{x}}{dt} = \hat{v}. \quad (6.273)$$

Take now the time derivative of Eq. (6.273) and substitute it into Eq. (6.272) to get the second order linear differential equation:

$$\frac{d^2 \hat{x}}{dt^2} + k \frac{P_o A}{m x_o} \left(\frac{P_\infty}{P_o} \right)^{\frac{1+k}{k}} \hat{x} = 0. \quad (6.274)$$

We can rewrite this in the form of a mass-spring type problem as

$$m \frac{d^2 \hat{x}}{dt^2} + k_s \hat{x} = 0, \quad (6.275)$$

$$k_s = k \frac{P_o A}{x_o} \left(\frac{P_\infty}{P_o} \right)^{\frac{1+k}{k}}. \quad (6.276)$$

The solution of this equation is well known to be

$$x(t) = C_1 \sin \left(\sqrt{\frac{k_s}{m}} t \right) + C_2 \cos \left(\sqrt{\frac{k_s}{m}} t \right). \quad (6.277)$$

The solution is oscillatory and has time constant

$$\tau = \sqrt{\frac{m}{k_s}} = \sqrt{\frac{m x_o}{k P_o A} \left(\frac{P_o}{P_\infty} \right)^{\frac{k+1}{k}}}. \quad (6.278)$$

At early time one can also do a similar linear analysis in the neighborhood of $x \sim x_o$ and $v \sim 0$. One can define new variables $\tilde{x} = x - x_o$, $\tilde{v} = v$, linearize the equations, and solve at early time.

6.7.2 Calorically imperfect

Consider now an isentropic relation for a CIIG. Recall from Eq. (6.98) that there is no simple way to write the algebraic form of the entropy, that relies on an integral, available in tabular form. Consideration of CIIGs usually relies on an unusual combination of table look-up and equations.

We can use Eq. (6.98) to write the entropy at states 1 and 2 as

$$s_1 = s_{T_1}^o - R \ln \frac{P_1}{P_o}, \quad (6.279)$$

$$s_2 = s_{T_2}^o - R \ln \frac{P_2}{P_o}. \quad (6.280)$$

Recall o denotes the reference pressure, and s_T^o is a temperature-dependent function, that is available in tabular form. So the entropy difference, $s_2 - s_1$, is

$$s_2 - s_1 = s_{T_2}^o - s_{T_1}^o - R \left(\ln \frac{P_2}{P_o} - \ln \frac{P_1}{P_o} \right), \quad (6.281)$$

$$= s_{T_2}^o - s_{T_1}^o - R \ln \left(\frac{P_2 P_o}{P_o P_1} \right), \quad (6.282)$$

$$= s_{T_2}^o - s_{T_1}^o - R \ln \left(\frac{P_2}{P_1} \right). \quad (6.283)$$

If the process is isentropic, we have $s_2 = s_1$, and so

$$0 = s_{T_2}^o - s_{T_1}^o - R \ln \frac{P_2}{P_1}, \quad (6.284)$$

$$s_{T_2}^o - s_{T_1}^o = R \ln \frac{P_2}{P_1}. \quad (6.285)$$

Example 6.12

Air is isentropically compressed from $T_1 = 300$ K, $P_1 = 100$ kPa to $T_2 = 2000$ K. Find the final pressure with a CIIG and CPIG model. Find the work per unit mass of compression for CIIG and CPIG models.

First consider the first law, $u_2 - u_1 = {}_1q_2 - {}_1w_2$. Because the process is isentropic, ${}_1q_2 = 0$, so

$${}_1w_2 = u_1 - u_2, \quad (6.286)$$

for both the CIIG and CPIG.

- *CIIG analysis:* For the CIIG, we find from Table A.7.1 of BS that

$$u_1 = 214.36 \frac{\text{kJ}}{\text{kg}}, \quad u_2 = 1677.52 \frac{\text{kJ}}{\text{kg}}. \quad (6.287)$$

So

$${}_1w_2 = u_1 - u_2 = \boxed{-1463.16 \frac{\text{kJ}}{\text{kg}}}. \quad (6.288)$$

The work is negative because the fluid is being worked upon.

For this system, Table A.7.1 gives

$$s_{T_1}^o = 6.86926 \frac{\text{kJ}}{\text{kg K}}, \quad s_{T_2}^o = 8.96611 \frac{\text{kJ}}{\text{kg K}}. \quad (6.289)$$

Now, apply Eq. (6.285) for the isentropic process:

$$s_{T_2}^o - s_{T_1}^o = R \ln \frac{P_2}{P_1}, \quad (6.290)$$

$$P_2 = P_1 \exp \left(\frac{s_{T_2}^o - s_{T_1}^o}{R} \right), \quad (6.291)$$

$$= (100 \text{ kPa}) \exp \left(\frac{\left(8.96611 \frac{\text{kJ}}{\text{kg K}} \right) - \left(6.86926 \frac{\text{kJ}}{\text{kg K}} \right)}{0.287 \frac{\text{kJ}}{\text{kg K}}} \right), \quad (6.292)$$

$$= \boxed{148935 \text{ kPa}}. \quad (6.293)$$

- *CPIG analysis*: For the CPIG, with $c_v = 0.7175 \text{ kJ/kg/K}$, we have

$${}_1w_2 = u_1 - u_2 = c_v(T_1 - T_2) = \left(0.7175 \frac{\text{kJ}}{\text{kg K}}\right) ((300 \text{ K}) - (2000 \text{ K})) = \boxed{-1219.75 \frac{\text{kJ}}{\text{kg}}}. \quad (6.294)$$

And we have from Eq. (6.169) for an isentropic CPIG, with $k = 7/5$

$$P_2 = P_1 \left(\frac{T_2}{T_1}\right)^{\frac{k}{k-1}} = (100 \text{ kPa}) \left(\frac{2000 \text{ K}}{300 \text{ K}}\right)^{\frac{7/5}{7/5-1}} = \boxed{76503.4 \text{ kPa}}. \quad (6.295)$$

Note the pressure from the CPIG model is half that from the CIIG model! This illustrates the dangers of using a CPIG model for high temperature applications.

If we had chosen $T_2 = 400 \text{ K}$, the CIIG model would have given $P_2 = 274.7 \text{ kPa}$, and the CPIG model would have given $P_2 = 273.7 \text{ kPa}$. This emphasizes at low temperatures, the CPIG is an accurate model.

6.8 Two cycles

In this section, we describe two important thermodynamic cycles. The most scientifically important is the *Carnot cycle*, and we spend some effort in its exposition. We contrast this with the *Otto cycle*, that is used to model the operation of gasoline engines.

6.8.1 Carnot

Motivated by a practical desire to improve French industry in the aftermath of military defeats of earlier decades, Nicolas Léonard Sadi Carnot (1796-1832), (son of the mathematician and architect of the military success of the early French revolution, Lazare Carnot) developed an *impractical* engine with great theoretical importance. Though the so-called Carnot engine has never been built, it represents the best heat engine that could be built, and imposes useful restrictions for practical engineers with visions of unrealizable efficiencies. Most importantly, the analysis of Carnot demonstrates how perpetual motion machines of the first and second kind cannot exist. Those of the first kind violate the first law of thermodynamics; those of the second kind violate the second law of thermodynamics.

Let us use a piston-cylinder arrangement to illustrate a Carnot cycle. See the sketch of Fig. 6.24. A sketch of the process in both the $P - v$ and $T - s$ planes for a CPIG is given in Fig. 6.25.

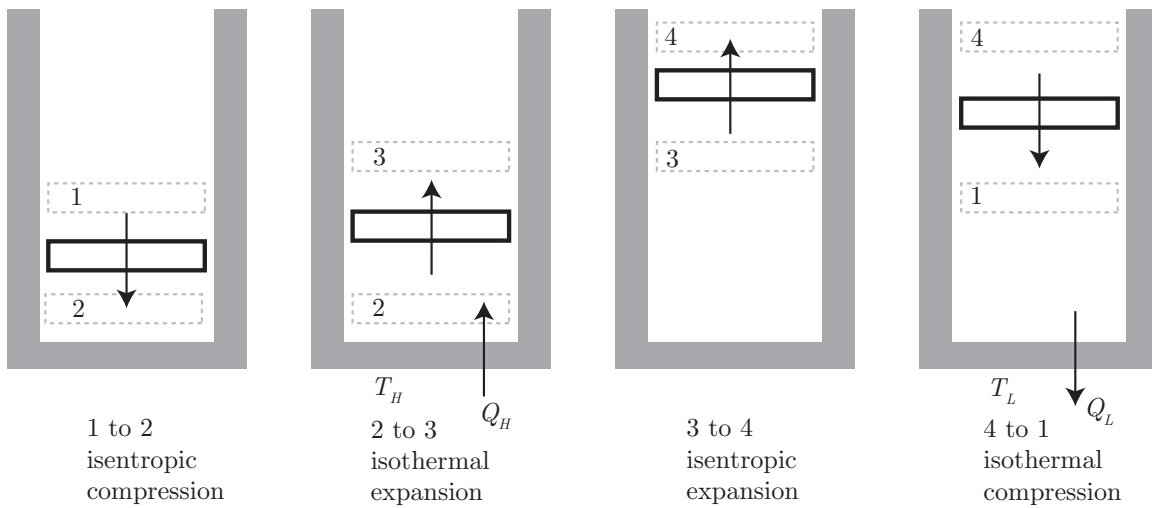
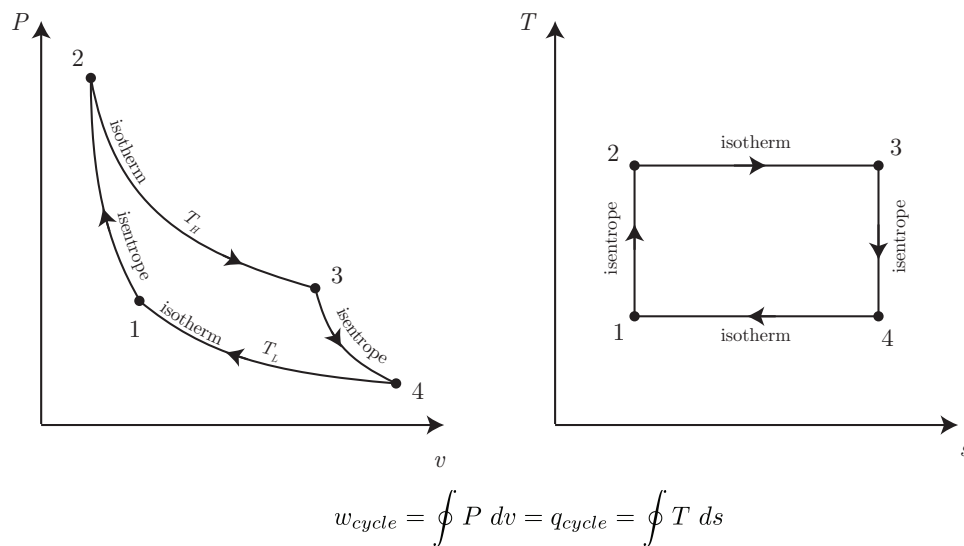

Figure 6.24: Sketch of Carnot cycle piston-cylinder device.

Figure 6.25: Sketch of a Carnot cycle for a CPIG represented in the $P - v$ and $T - s$ planes.

The Carnot cycle is defined in four stages. Here, we use a different identification of the states 1, 2, 3, and 4 than do BS to be consistent with more common notation that will be used later for other engines by BS and most other texts. The four stages are

- 1 \rightarrow 2: adiabatic reversible (isentropic) compression ($Q = 0$) from T_L to T_H ,
- 2 \rightarrow 3: isothermal reversible expansion at T_H ,
- 3 \rightarrow 4: adiabatic reversible (isentropic) expansion from T_H to T_L , and
- 4 \rightarrow 1: isothermal compression at T_L .

We always assume the same fluid is present within the Carnot engine, and ignore the effects of valves. We also ignore the effect of mixtures of combustible gases.

The Carnot cycle for a CPIG is such a foundational idealization for mechanical engineers that it is centrally incorporated in the logo of the international mechanical engineering academic honor society, Pi Tau Sigma ($\Pi\tau\sigma$). The logo is reproduced in Fig. 6.26.



Figure 6.26: Logo of the international mechanical engineering honor society, Pi Tau Sigma ($\Pi\tau\sigma$) featuring the Carnot cycle for a CPIG in the $P - v$ plane as displayed on the campus of the University of Notre Dame.

Example 6.13

Given k , R , $T_L = T_1 = T_4$, $T_H = T_2 = T_3$, v_1 and v_4 , demonstrate for a CPIG undergoing a Carnot cycle, that the earlier derived Eq. (5.23), $\eta = 1 - T_L/T_H$, is true. Also find the net work and heat transfer.

First note that $c_v = R/(k - 1)$.

- For process 1 → 2, we have the first law

$$\underbrace{u_2 - u_1}_{=c_v(T_2-T_1)} = \underbrace{{}_1q_2}_{=0} - \underbrace{{}_1w_2}_{=\int_1^2 P dv}, \quad (6.296)$$

$$c_v(T_2 - T_1) = - \int_1^2 P dv, \quad (6.297)$$

$$c_v(T_H - T_L) = - \int_1^2 P dv, \quad (6.298)$$

$$\left(\frac{R}{k-1}\right)(T_H - T_L) = - \int_1^2 P dv. \quad (6.299)$$

For the isentropic process $Pv^k = P_1v_1^k$, and we know from the per mass version of Eq. (3.79) for work for a polytropic process that when $n = k$, the work must be

$${}_1w_2 = \frac{P_2v_2 - P_1v_1}{1-k}, \quad (6.300)$$

$$= \frac{RT_2 - RT_1}{1-k}, \quad (6.301)$$

$$= -\frac{R}{k-1}(T_2 - T_1), \quad (6.302)$$

$$= -\frac{R}{k-1}(T_H - T_L). \quad (6.303)$$

This is consistent with the change in internal energy being the negative of the work done.

- For process 2 → 3, the first law gives

$$u_3 - u_2 = {}_2q_3 - {}_2w_3, \quad (6.304)$$

$$c_v \underbrace{(T_3 - T_2)}_{=0} = {}_2q_3 - \int_2^3 P dv, \quad (6.305)$$

$${}_2q_3 = \int_2^3 P dv, \quad (6.306)$$

$$= RT_H \int_2^3 \frac{dv}{v}, \quad (6.307)$$

$$= RT_H \ln \frac{v_3}{v_2}. \quad (6.308)$$

Now, we have from the isentropic relations that

$$v_2 = v_1 \left(\frac{T_1}{T_2}\right)^{\frac{1}{k-1}} = v_1 \left(\frac{T_L}{T_H}\right)^{\frac{1}{k-1}}, \quad v_3 = v_4 \left(\frac{T_L}{T_H}\right)^{\frac{1}{k-1}}. \quad (6.309)$$

So

$${}_2q_3 = RT_H \ln \left(\frac{v_4 \left(\frac{T_L}{T_H}\right)^{\frac{1}{k-1}}}{v_1 \left(\frac{T_L}{T_H}\right)^{\frac{1}{k-1}}} \right) = RT_H \ln \frac{v_4}{v_1}. \quad (6.310)$$

- For process 3 → 4, the first law gives

$$u_4 - u_3 = \underbrace{3q_4}_{=0} - {}_3w_4, \quad (6.311)$$

$$c_v(T_4 - T_3) = -{}_3w_4, \quad (6.312)$$

$$\left(\frac{R}{k-1}\right)(T_L - T_H) = -{}_3w_4. \quad (6.313)$$

- For process 4 → 1, the first law gives

$$u_1 - u_4 = {}_4q_1 - {}_4w_1, \quad (6.314)$$

$$\underbrace{c_v(T_1 - T_4)}_{=0} = {}_4q_1 - \int_4^1 P \, dv, \quad (6.315)$$

$${}_4q_1 = \int_4^1 P \, dv, \quad (6.316)$$

$$= RT_L \int_1^4 \frac{dv}{v}, \quad (6.317)$$

$$= RT_L \ln \frac{v_1}{v_4}. \quad (6.318)$$

Now, we know the thermal efficiency is from Eq. (5.10)

$$\eta = 1 - \frac{Q_L}{Q_H}. \quad (6.319)$$

For us

$$Q_L \sim |{}_4q_1| = \left| RT_L \ln \frac{v_1}{v_4} \right| = RT_L \ln \frac{v_4}{v_1}, \quad (6.320)$$

$$Q_H \sim |{}_2q_3| = \left| RT_H \ln \frac{v_4}{v_1} \right| = RT_H \ln \frac{v_4}{v_1}. \quad (6.321)$$

So

$$\eta = 1 - \frac{RT_L \ln \frac{v_4}{v_1}}{RT_H \ln \frac{v_4}{v_1}}, \quad (6.322)$$

$$\boxed{\eta = 1 - \frac{T_L}{T_H}}, \quad Q.E.D.^{10} \quad (6.323)$$

Also, we easily get the net work and heat transfer via

$$w_{cycle} = q_{cycle} = {}_2q_3 + {}_4q_1 = RT_H \ln \frac{v_4}{v_1} + RT_L \ln \frac{v_1}{v_4} = \boxed{R(T_H - T_L) \ln \frac{v_4}{v_1}}. \quad (6.324)$$

We summarize the first law statements in Table 6.2.

¹⁰abbreviation of the Latin phrase, *quod erat demonstrandum*, “that which was to have been demonstrated.” The original Greek version, used by Euclid and Archimedes, was $\acute{o}\pi\epsilon\rho\acute{\epsilon}\delta\epsilon\iota\delta\epsilon\iota\zeta\alpha\iota$, translated as “precisely what was required to be proved,” (<https://en.wikipedia.org/wiki/Q.E.D.>).

| Process | Δu | q | w |
|-------------------|-----------------------------|------------------------------------|------------------------------------|
| 1 \rightarrow 2 | $\frac{R}{k-1}(T_H - T_L)$ | 0 | $-\frac{R}{k-1}(T_H - T_L)$ |
| 2 \rightarrow 3 | 0 | $RT_H \ln \frac{v_3}{v_2}$ | $RT_H \ln \frac{v_3}{v_2}$ |
| 3 \rightarrow 4 | $-\frac{R}{k-1}(T_H - T_L)$ | 0 | $\frac{R}{k-1}(T_H - T_L)$ |
| 4 \rightarrow 1 | 0 | $RT_L \ln \frac{v_1}{v_4}$ | $RT_L \ln \frac{v_1}{v_4}$ |
| Total | 0 | $R(T_H - T_L) \ln \frac{v_3}{v_2}$ | $R(T_H - T_L) \ln \frac{v_3}{v_2}$ |

Table 6.2: First law analysis summary for our CPIG undergoing a Carnot cycle.

Example 6.14

A mass of $m = 1$ kg of water executes a Carnot cycle. The high temperature isothermal expansion is from $P_2 = 15$ bar, $x_2 = 0.25$ to the saturated vapor state. The adiabatic expansion is to $P_4 = 1$ bar. Analyze the system.

The system is sketched in Fig. 6.27. We have $P_2 = 1500$ kPa, $x_2 = 0.25$. From the tables we find

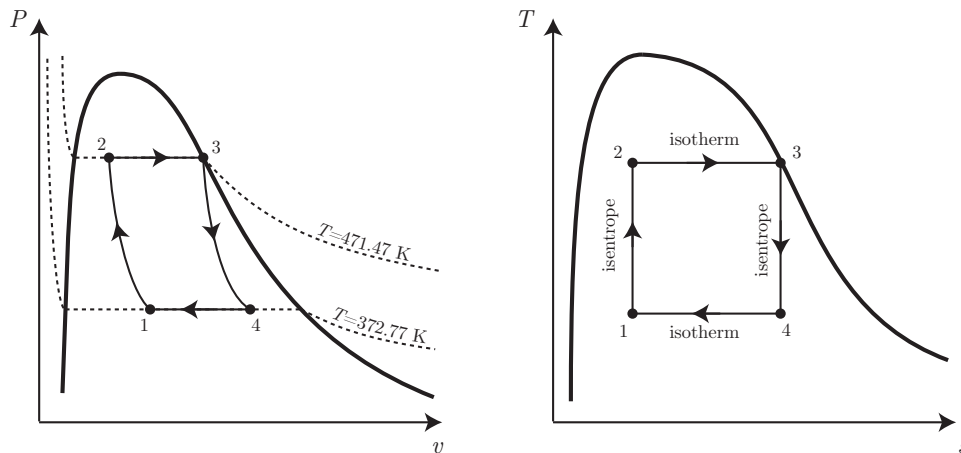
Figure 6.27: Sketch of a Carnot cycle for water represented in the $P - v$ and $T - s$ planes.

the following

$$T_2 = 198.32 \text{ }^\circ\text{C} = 471.47 \text{ K}, \quad (6.325)$$

$$v_{f2} = 0.001154 \frac{\text{m}^3}{\text{kg}}, \quad v_{fg2} = 0.13062 \frac{\text{m}^3}{\text{kg}}. \quad (6.326)$$

$$u_{f2} = 843.14 \frac{\text{kJ}}{\text{kg}}, \quad u_{fg2} = 1751.3 \frac{\text{kJ}}{\text{kg}}, \quad (6.327)$$

$$s_{f2} = 2.3150 \frac{\text{kJ}}{\text{kg K}}, \quad s_{fg2} = 4.1298 \frac{\text{kJ}}{\text{kg K}}. \quad (6.328)$$

So we get the properties of state 2 via

$$v_2 = v_{f2} + x_2 v_{fg2} = 0.033809 \frac{\text{m}^3}{\text{kg}}, \quad (6.329)$$

$$u_2 = u_{f2} + x_2 u_{fg2} = 1280.97 \frac{\text{kJ}}{\text{kg}}, \quad (6.330)$$

$$s_2 = s_{f2} + x_2 s_{fg2} = 3.3475 \frac{\text{kJ}}{\text{kg K}}. \quad (6.331)$$

At state 3, we know $P_3 = P_2 = 1500$ kPa, and $x_3 = 1$, so the properties can be read from the saturated water tables for $x_3 = 1$. We find

$$v_3 = 0.13177 \frac{\text{m}^3}{\text{kg}}, \quad (6.332)$$

$$u_3 = 2594.5 \frac{\text{kJ}}{\text{kg}}, \quad (6.333)$$

$$s_3 = 6.4448 \frac{\text{kJ}}{\text{kg K}}. \quad (6.334)$$

At state 4, we know $P_4 = 100$ kPa. We also know that $s_4 = s_3 = 6.4448$ kJ/kg/K. So the state is fixed. At state 4, the tables give

$$T_4 = 99.62 \text{ }^\circ\text{C} = 372.77 \text{ K}, \quad (6.335)$$

$$v_{f4} = 0.001043 \frac{\text{m}^3}{\text{kg}}, \quad v_{fg4} = 1.69296 \frac{\text{m}^3}{\text{kg}}, \quad (6.336)$$

$$u_{f4} = 417.33 \frac{\text{kJ}}{\text{kg}}, \quad u_{fg4} = 2088.72 \frac{\text{kJ}}{\text{kg}}, \quad (6.337)$$

$$s_{f4} = 1.3025 \frac{\text{kJ}}{\text{kg K}}, \quad s_{fg4} = 6.0568 \frac{\text{kJ}}{\text{kg K}}. \quad (6.338)$$

Knowing s_4 , we can find the quality x_4 via

$$x_4 = \frac{s_4 - s_{f4}}{s_{fg4}} = \frac{\left(6.4448 \frac{\text{kJ}}{\text{kg K}}\right) - \left(1.3025 \frac{\text{kJ}}{\text{kg K}}\right)}{6.0568 \frac{\text{kJ}}{\text{kg K}}} = 0.849013. \quad (6.339)$$

We then find

$$v_4 = v_{f4} + x_4 v_{fg4} = 1.43838 \frac{\text{m}^3}{\text{kg}}, \quad (6.340)$$

$$u_4 = u_{f4} + x_4 u_{fg4} = 2190.68 \frac{\text{kJ}}{\text{kg}}. \quad (6.341)$$

Now, we know that for state 1, $s_1 = s_2 = 3.3475$ kJ/kg/K, and $s_{f1} = s_{f4}$, $s_{fg1} = s_{fg4}$. So

$$x_1 = \frac{s_1 - s_{f1}}{s_{fg1}} = 0.337629. \quad (6.342)$$

We also know that $T_1 = T_4 = 372.77$ K. We also know that $v_{f1} = v_{f4}$, $v_{fg1} = v_{fg4}$, $u_{f1} = u_{f4}$, $u_{fg1} = u_{fg4}$. So

$$v_1 = v_{f1} + x_1 v_{fg1} = 0.572634 \frac{\text{m}^3}{\text{kg}}, \quad (6.343)$$

$$u_1 = u_{f1} + x_1 u_{fg1} = 1122.54 \frac{\text{kJ}}{\text{kg}}. \quad (6.344)$$

Now, let us consider the first law for each process.

- 1 → 2: The first law gives

$$u_2 - u_1 = \underbrace{{}_1q_2}_{=0} - {}_1w_2, \quad (6.345)$$

$${}_1w_2 = u_1 - u_2, \quad (6.346)$$

$${}_1w_2 = \left(1122.54 \frac{\text{kJ}}{\text{kg}} \right) - \left(1280.97 \frac{\text{kJ}}{\text{kg}} \right), \quad (6.347)$$

$$= -158.423 \frac{\text{kJ}}{\text{kg}}. \quad (6.348)$$

- 2 → 3: The first law gives

$$u_3 - u_2 = {}_2q_3 - {}_2w_3. \quad (6.349)$$

Now,

$${}_2w_3 = \int_2^3 P dv, \quad (6.350)$$

$$= P_3(v_3 - v_2), \quad (6.351)$$

$$= (1500 \text{ kPa}) \left(\left(0.13177 \frac{\text{m}^3}{\text{kg}} \right) - \left(0.033809 \frac{\text{m}^3}{\text{kg}} \right) \right), \quad (6.352)$$

$$= 146.942 \frac{\text{kJ}}{\text{kg}}. \quad (6.353)$$

So

$${}_2q_3 = (u_3 - u_2) + {}_2w_3, \quad (6.354)$$

$$= \left(\left(2594.5 \frac{\text{kJ}}{\text{kg}} \right) - \left(1280.97 \frac{\text{kJ}}{\text{kg}} \right) \right) + \left(146.942 \frac{\text{kJ}}{\text{kg}} \right), \quad (6.355)$$

$$= 1460.48 \frac{\text{kJ}}{\text{kg}}. \quad (6.356)$$

- 3 → 4: The first law gives

$$u_4 - u_3 = \underbrace{{}_3q_4}_{=0} - {}_3w_4. \quad (6.357)$$

So

$${}_3w_4 = u_3 - u_4, \quad (6.358)$$

$$= \left(2594.5 \frac{\text{kJ}}{\text{kg}} \right) - \left(2190.68 \frac{\text{kJ}}{\text{kg}} \right), \quad (6.359)$$

$$= 403.82 \frac{\text{kJ}}{\text{kg}}. \quad (6.360)$$

- $4 \rightarrow 1$: The first law gives

$$u_1 - u_4 = {}_4q_1 - {}_4w_1. \quad (6.361)$$

Now

$${}_4w_1 = \int_4^1 P \, dv, \quad (6.362)$$

$$= P_1(v_1 - v_4), \quad (6.363)$$

$$= (100 \text{ kPa}) \left(\left(0.572634 \frac{\text{m}^3}{\text{kg}} \right) - \left(1.43838 \frac{\text{m}^3}{\text{kg}} \right) \right), \quad (6.364)$$

$$= -86.5751 \frac{\text{kJ}}{\text{kg}}. \quad (6.365)$$

So

$${}_4q_1 = (u_1 - u_4) + {}_4w_1, \quad (6.366)$$

$$= \left(\left(1122.54 \frac{\text{kJ}}{\text{kg}} \right) - \left(2190.68 \frac{\text{kJ}}{\text{kg}} \right) \right) + \left(-86.5751 \frac{\text{kJ}}{\text{kg}} \right), \quad (6.367)$$

$$= -1154.71 \frac{\text{kJ}}{\text{kg}}. \quad (6.368)$$

The net work for the cycle is

$$w_{cycle} = {}_1w_2 + {}_2w_3 + {}_3w_4 + {}_4w_1, \quad (6.369)$$

$$= \left(-158.423 \frac{\text{kJ}}{\text{kg}} \right) + \left(146.942 \frac{\text{kJ}}{\text{kg}} \right) + \left(403.82 \frac{\text{kJ}}{\text{kg}} \right) + \left(-86.5751 \frac{\text{kJ}}{\text{kg}} \right), \quad (6.370)$$

$$= 305.764 \frac{\text{kJ}}{\text{kg}}. \quad (6.371)$$

The net heat transfer for the cycle is

$$q_{cycle} = {}_2q_3 + {}_4q_1, \quad (6.372)$$

$$= \left(1460.48 \frac{\text{kJ}}{\text{kg}} \right) + \left(-1154.71 \frac{\text{kJ}}{\text{kg}} \right), \quad (6.373)$$

$$= 305.764 \frac{\text{kJ}}{\text{kg}}. \quad (6.374)$$

Note that, as expected $w_{cycle} = q_{cycle}$. Now, let us calculate the thermal efficiency.

$$\eta = \frac{w_{cycle}}{q_{in}}, \quad (6.375)$$

$$= \frac{w_{cycle}}{{}_2q_3}, \quad (6.376)$$

$$= \frac{305.764 \frac{\text{kJ}}{\text{kg}}}{1460.48 \frac{\text{kJ}}{\text{kg}}}, \quad (6.377)$$

$$= 0.209359. \quad (6.378)$$

This should be the same as the Carnot theory's prediction

$$\eta = 1 - \frac{T_L}{T_H}, \quad (6.379)$$

$$= 1 - \frac{372.77 \text{ K}}{471.47 \text{ K}}, \quad (6.380)$$

$$= 0.209345. \quad (6.381)$$

| Process | Δu $\left(\frac{\text{kJ}}{\text{kg}}\right)$ | q $\left(\frac{\text{kJ}}{\text{kg}}\right)$ | w $\left(\frac{\text{kJ}}{\text{kg}}\right)$ |
|-------------------|---|--|--|
| 1 \rightarrow 2 | 158.423 | 0 | -158.423 |
| 2 \rightarrow 3 | 1313.54 | 1460.48 | 146.942 |
| 3 \rightarrow 4 | -403.82 | 0 | 403.82 |
| 4 \rightarrow 1 | -1068.14 | -1154.71 | -86.5751 |
| Total | 0 | 305.764 | 305.764 |

Table 6.3: First law analysis summary for our water undergoing a Carnot cycle.

The small differences are likely due to interpolation error from using the tables. We summarize the first law statements in Table 6.3.

6.8.2 Otto

The Otto cycle approximates the gasoline engine using what is known as an *air standard* approximation. The air standard will be considered in more detail in Ch. 8.2. It is named for Nikolaus Otto, depicted in Fig. 6.28. Many details are ignored (like inlet and exhaust),



Figure 6.28: Nikolaus August Otto (1832-1891), German developer of the internal combustion engine. Image from https://en.wikipedia.org/wiki/Nicholas_Otto.

and all material properties are taken to be those of air modeled as a CPIG. It employs a *fixed mass* approach. Diagrams for $P - v$ and $T - s$ for the Otto cycle are shown in Fig. 6.29. One can outline the Otto cycle as follows:

- 1 \rightarrow 2: isentropic compression in the compression stroke,
- 2 \rightarrow 3: isochoric heating in the combustion stroke during spark ignition,

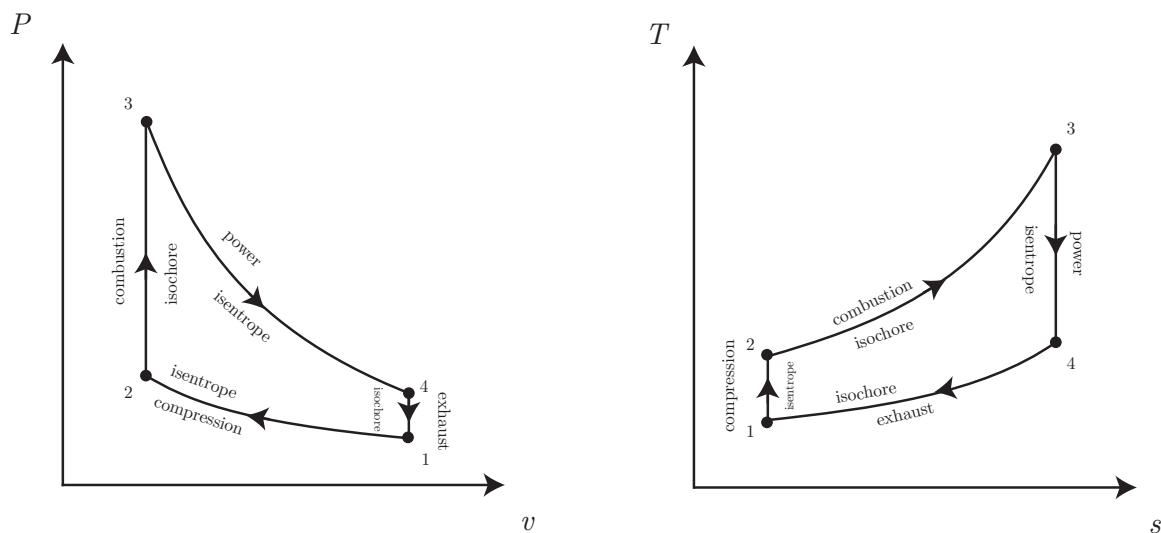
Figure 6.29: $P - v$ and $T - s$ diagrams for the Otto cycle.

- 3 \rightarrow 4: isentropic expansion in power stroke, and
- 4 \rightarrow 1: isochoric rejection of heat to the surroundings.

Clearly, the cycle is not a Carnot cycle. The heat transfer during the combustion and exhaust strokes does not take place at constant temperature. Roughly speaking, *we might expect degradation of the thermal efficiency, relative to an equivalent Carnot engine operating between the same temperature bounds, because some of the heat transfer of the Otto cycle occurs at lower temperatures than other parts of the cycle.* Recall that for maximum Carnot efficiency, we would like T_H as high as possible. Just past state 2, the heat transferred at T_2 is at a lower temperature than the heat transferred at T_3 .

Note for isochoric heating, such as 2 \rightarrow 3, in a fixed mass environment, the first law gives

$$u_3 - u_2 = 2q_3 - 2w_3, \quad (6.382)$$

$$= 2q_3 - \int_{v_2}^{v_3} P \, dv, \quad \text{but } v_2 = v_3, \quad (6.383)$$

$$= 2q_3 - \underbrace{\int_{v_2}^{v_2} P \, dv}_{=0}, \quad (6.384)$$

$$2q_3 = u_3 - u_2, \quad (6.385)$$

$$= c_v(T_3 - T_2), \quad \text{if CPIG.} \quad (6.386)$$

This will give us

$$Q_H = mc_v(T_3 - T_2). \quad (6.387)$$

Similarly for the isochoric heat rejection, we have

$$Q_L = m|_4q_1| = mc_v|T_1 - T_4| = mc_v(T_4 - T_1). \quad (6.388)$$

The thermal efficiency is found as follows:

$$\eta = \frac{W_{net}}{Q_H}, \quad (6.389)$$

$$= \frac{Q_H - Q_L}{Q_H}, \quad (6.390)$$

$$= 1 - \frac{Q_L}{Q_H}, \quad (6.391)$$

$$= 1 - \frac{mc_v(T_4 - T_1)}{mc_v(T_3 - T_2)}, \quad (6.392)$$

$$= 1 - \frac{T_4 - T_1}{T_3 - T_2}, \quad (6.393)$$

$$= 1 - \frac{T_1 \left(\frac{T_4}{T_1} - 1 \right)}{T_2 \left(\frac{T_3}{T_2} - 1 \right)}. \quad (6.394)$$

Now, one also has the isentropic relations:

$$\frac{T_2}{T_1} = \left(\frac{V_1}{V_2} \right)^{k-1}, \quad (6.395)$$

$$\frac{T_3}{T_4} = \left(\frac{V_4}{V_3} \right)^{k-1}. \quad (6.396)$$

But $V_4 = V_1$ and $V_2 = V_3$, so

$$\frac{T_3}{T_4} = \left(\frac{V_1}{V_2} \right)^{k-1} = \frac{T_2}{T_1}. \quad (6.397)$$

Cross multiplying the temperatures, one finds

$$\frac{T_3}{T_2} = \frac{T_4}{T_1}. \quad (6.398)$$

Thus, the thermal efficiency reduces to

$$\eta = 1 - \frac{T_1}{T_2}. \quad (6.399)$$

This looks a lot like the Carnot efficiency. But for a Carnot engine operating between the same temperature bounds, we would have found $\eta = 1 - T_1/T_3$. Because $T_3 > T_2$, the Carnot engine is more efficient than the ideal Otto engine. This identifies an important

- **THERMAL ENGINE DESIGN PRINCIPLE:** To optimize the performance of a thermal engine, the $T - s$ diagram describing its behavior should be as close to a rectangle as possible, with the highest possible T_H and the lowest possible T_L .

One often finds commercial engines characterized by their compression ratios. Modern gasoline engines may have compression ratios of $r_v = 10$. In terms of the compression ratio $r_v = V_1/V_2$, one has

$$\eta = 1 - r_v^{1-k} = 1 - \frac{1}{r_v^{k-1}}. \quad (6.400)$$

Note if the compression ratio increases, the thermal efficiency increases, so this is desirable, in principle. However, high compression ratios introduces a variety of problems including 1) loss of material strength of hot metals in the engine, 2) higher incidence of detonation or knock in the combustion process, 3) greater tendency to form harmful pollutants such as NO_x .

Some deviations of actual performance from that of the air-standard Otto cycle are as follows:

- specific heats actually vary with temperature,
- combustion may be incomplete (induces pollution and lowers fuel efficiency),
- work of inlet and exhaust is ignored, and
- losses of heat transfer to engine walls are ignored.

Example 6.15

The temperature prior to compression in an air-standard Otto cycle with a compression ratio of 7 is 500°R , and the pressure is 1 atm. The maximum temperature is 3500°R . Find

- temperature and pressure at each stage of the process, and
- thermal efficiency.

For the isentropic compression,

$$T_2 = T_1 \left(\frac{V_1}{V_2} \right)^{k-1}, \quad (6.401)$$

$$= (500^\circ\text{R})(7)^{1.4-1}, \quad (6.402)$$

$$= 1088.95^\circ\text{R}. \quad (6.403)$$

One can use the ideal gas law to get the pressure at state 2:

$$\frac{P_2 V_2}{T_2} = \frac{P_1 V_1}{T_1}, \quad (6.404)$$

$$P_2 = P_1 \frac{V_1 T_2}{V_2 T_1}, \quad (6.405)$$

$$= (1 \text{ atm})(7) \left(\frac{1088.95^\circ\text{R}}{500^\circ\text{R}} \right), \quad (6.406)$$

$$= 15.2453 \text{ atm}. \quad (6.407)$$

Now, $V_3 = V_2$ because the combustion is isochoric. And the maximum temperature is $T_3 = 3500 \text{ }^\circ\text{R}$. This allows use of the ideal gas law to get P_3 :

$$\frac{P_3 V_3}{T_3} = \frac{P_2 V_2}{T_2}, \quad (6.408)$$

$$P_3 = P_2 \underbrace{\frac{V_2}{V_3}}_{=1} \frac{T_3}{T_2}, \quad (6.409)$$

$$= (15.2453 \text{ atm})(1) \left(\frac{3500 \text{ }^\circ\text{R}}{1088.95 \text{ }^\circ\text{R}} \right), \quad (6.410)$$

$$= 49 \text{ atm}. \quad (6.411)$$

One uses the isentropic relations for state 4:

$$\frac{T_3}{T_4} = \left(\frac{V_4}{V_3} \right)^{k-1}, \quad (6.412)$$

$$\frac{T_4}{T_3} = \left(\frac{V_3}{V_4} \right)^{k-1}, \quad (6.413)$$

$$T_4 = T_3 \left(\frac{V_2}{V_1} \right)^{k-1}, \quad (6.414)$$

$$= T_3 \left(\frac{V_1}{V_2} \right)^{1-k}, \quad (6.415)$$

$$= (3500 \text{ }^\circ\text{R})(7)^{1-1.4}, \quad (6.416)$$

$$= 1607.05 \text{ }^\circ\text{R}. \quad (6.417)$$

For the pressure at state 4, use the ideal gas law:

$$\frac{P_4 V_4}{T_4} = \frac{P_3 V_3}{T_3}, \quad (6.418)$$

$$P_4 = P_3 \frac{V_3 T_4}{V_4 T_3}, \quad (6.419)$$

$$= P_3 \frac{V_2 T_4}{V_1 T_3}, \quad (6.420)$$

$$= (49 \text{ atm}) \left(\frac{1}{7} \right) \frac{1607.05 \text{ }^\circ\text{R}}{3500 \text{ }^\circ\text{R}}, \quad (6.421)$$

$$= 3.2141 \text{ atm}. \quad (6.422)$$

The thermal efficiency is

$$\eta = 1 - \frac{1}{r_v^{k-1}}, \quad (6.423)$$

$$= 1 - \frac{1}{7^{1.4-1}}, \quad (6.424)$$

$$= 0.54083. \quad (6.425)$$

A Carnot engine operating between the same upper and lower temperature limits would have had thermal efficiency $\eta = 1 - (500 \text{ }^\circ\text{R})/(3500 \text{ }^\circ\text{R}) = 0.857143$.

6.9 Entropy of thermo-mechanical mixing

We believe from experience that mixing is most likely a process that is entropy-generating. For instance, it is easy to mix water and ink together, but hard to separate them into their original components. Separation can be accomplished, but it takes energy. Now, we can also mix the energy of components. We might imagine two gases at different states. This is a structured arrangement. When the two gases mix, they come to a new equilibrium without external impetus. There is consequently less structure in the universe, and the entropy should go up. Moreover, it would require an external action to return the system to its original state. Let us first demonstrate this with a simple example of thermo-mechanically mixing of two CPIGs initially at different temperatures and pressures, but with otherwise identical properties. We will enforce thermal equilibrium via temperature equilibration and mechanical equilibrium via pressure equilibration.

Example 6.16

Consider a fixed volume chamber that is thermally insulated from its outer surroundings and thus globally adiabatic. The fixed volume chamber is initially divided into two compartments A and B , by a thin, thermally insulated barrier. Both compartments contain CPIG air ($R = 0.287$ kJ/kg/K, $c_v = 0.7175$ kJ/kg/K). We have $P_A = 100$ kPa, $T_A = 300$ K, $m_A = 10$ kg, $P_B = 200$ kPa, $T_B = 500$ K, and $m_B = 2$ kg. The thin barrier is removed, and the combined system comes to a new mechanical and thermal equilibrium at state C . Find the entropy change of the universe.

The process is sketched in Fig. 6.30. Use the ideal gas law to get the various volumes:

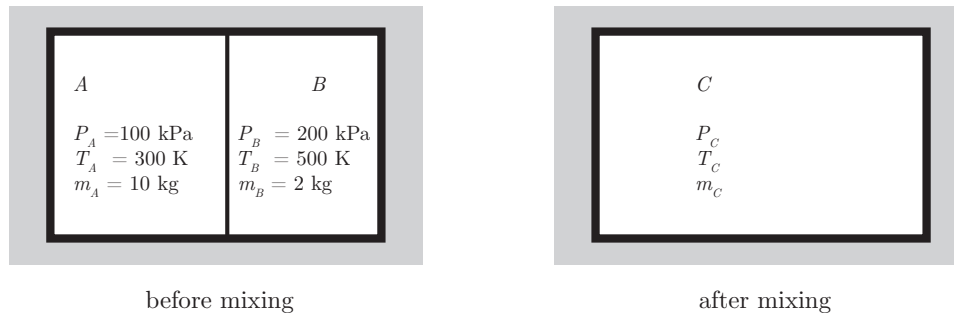

Figure 6.30: Schematic for globally adiabatic thermo-mechanical mixing problem.

$$v_A = \frac{RT_A}{P_A}, \quad v_B = \frac{RT_B}{P_B}. \quad (6.426)$$

$$V_A = m_A v_A = \frac{m_A R T_A}{P_A}, \quad V_B = m_B v_B = \frac{m_B R T_B}{P_B}. \quad (6.427)$$

Now, mass conservation gives

$$m_C = m_A + m_B, \quad (6.428)$$

$$= (10 \text{ kg}) + (2 \text{ kg}), \quad (6.429)$$

$$= 12 \text{ kg}. \quad (6.430)$$

By geometry, we have

$$V_C = V_A + V_B = \frac{m_A R T_A}{P_A} + \frac{m_B R T_B}{P_B} = R \left(\frac{m_A T_A}{P_A} + \frac{m_B T_B}{P_B} \right). \quad (6.431)$$

So we can get one intensive property at the final state:

$$v_C = \frac{V_C}{m_C} = \frac{R \left(\frac{m_A T_A}{P_A} + \frac{m_B T_B}{P_B} \right)}{m_A + m_B}. \quad (6.432)$$

We can use the first law of thermodynamics to get a second property at the final state:

$$U_C - (U_A + U_B) = \underbrace{1Q_2}_{=0} - \underbrace{1W_2}_{=0}. \quad (6.433)$$

Because the combined system is adiabatic and isochoric, there is no global heat transfer or work during the process, so

$$U_C - (U_A + U_B) = 0, \quad (6.434)$$

$$U_C = U_A + U_B, \quad (6.435)$$

$$m_C c_v (T_C - T_o) = m_A c_v (T_A - T_o) + m_B c_v (T_B - T_o), \quad (6.436)$$

$$(m_A + m_B)(T_C - T_o) = m_A (T_A - T_o) + m_B (T_B - T_o), \quad (6.437)$$

$$(m_A + m_B)T_C = m_A T_A + m_B T_B, \quad (6.438)$$

$$T_C = \frac{m_A T_A + m_B T_B}{m_A + m_B}. \quad (6.439)$$

The mixture temperature, T_C is the mass-weighted average of the two initial temperatures. Note it would not matter if we used K or °C to get the mixture temperature. The final temperature for our system is

$$T_C = \frac{(10 \text{ kg})(300 \text{ K}) + (2 \text{ kg})(500 \text{ K})}{(10 \text{ kg}) + (2 \text{ kg})} = 333.333 \text{ K}. \quad (6.440)$$

Now, we can use the ideal gas to find the final pressure:

$$P_C = \frac{R T_C}{v_C} = R \frac{\frac{m_A T_A + m_B T_B}{m_A + m_B}}{\frac{R \left(\frac{m_A T_A}{P_A} + \frac{m_B T_B}{P_B} \right)}{m_A + m_B}} = \frac{m_A T_A + m_B T_B}{\frac{m_A T_A}{P_A} + \frac{m_B T_B}{P_B}}. \quad (6.441)$$

The final pressure is

$$P_C = \frac{(10 \text{ kg})(300 \text{ K}) + (2 \text{ kg})(500 \text{ K})}{\frac{(10 \text{ kg})(300 \text{ K})}{100 \text{ kPa}} + \frac{(2 \text{ kg})(500 \text{ K})}{200 \text{ kPa}}} = 114.286 \text{ kPa}. \quad (6.442)$$

Now, there are no interactions with the surroundings, so we need only consider the entropy changes of A and B . First consider the gas that starts at state A and finishes at state C

$$\Delta S_A = m_A \left(c_P \ln \frac{T_C}{T_A} - R \ln \frac{P_C}{P_A} \right), \quad (6.443)$$

$$\frac{\Delta S_A}{R} = m_A \left(\frac{c_P}{R} \ln \frac{T_C}{T_A} - \ln \frac{P_C}{P_A} \right), \quad (6.444)$$

$$= m_A \left(\frac{c_P}{c_P - c_v} \ln \frac{T_C}{T_A} - \ln \frac{P_C}{P_A} \right), \quad (6.445)$$

$$= m_A \left(\frac{k}{k-1} \ln \frac{T_C}{T_A} - \ln \frac{P_C}{P_A} \right), \quad (6.446)$$

$$\frac{\Delta S_A}{R(m_A + m_B)} = \frac{m_A}{m_A + m_B} \left(\ln \left(\frac{T_C}{T_A} \right)^{\frac{k}{k-1}} - \ln \frac{P_C}{P_A} \right), \quad (6.447)$$

$$= \frac{10 \text{ kg}}{(10 \text{ kg}) + (2 \text{ kg})} \left(\ln \left(\frac{333.333 \text{ K}}{300 \text{ K}} \right)^{\frac{1.4}{1.4-1}} - \ln \frac{114.286 \text{ kPa}}{100 \text{ kPa}} \right), \quad (6.448)$$

$$= 0.196025. \quad (6.449)$$

Here, we have generated a dimensionless entropy rise by scaling by Rm_C . Gas A saw its scaled entropy rise.

Similarly, for the gas that starts at B and ends at C , we have

$$\frac{\Delta S_B}{R(m_A + m_B)} = \frac{m_B}{m_A + m_B} \left(\ln \left(\frac{T_C}{T_B} \right)^{\frac{k}{k-1}} - \ln \frac{P_C}{P_B} \right), \quad (6.450)$$

$$= \frac{2 \text{ kg}}{(10 \text{ kg}) + (2 \text{ kg})} \left(\ln \left(\frac{333.333 \text{ K}}{500 \text{ K}} \right)^{\frac{1.4}{1.4-1}} - \ln \frac{114.286 \text{ kPa}}{200 \text{ kPa}} \right), \quad (6.451)$$

$$= -0.143252. \quad (6.452)$$

Gas B saw its scaled entropy fall.

The combined system has

$$\frac{\Delta S_A + \Delta S_B}{R(m_A + m_B)} = 0.196025 - 0.143252 = 0.0527733. \quad (6.453)$$

Dimensionally

$$\Delta S_A + \Delta S_B = (0.0527733)Rm_C = (0.0527733) \left(0.287 \frac{\text{kJ}}{\text{kg K}} \right) (12 \text{ kg}) = \boxed{0.181751 \frac{\text{kJ}}{\text{K}}}. \quad (6.454)$$

With some more effort, we could prove that the mixing of *arbitrary* initial states would result in a global entropy increase.

We note

- The entropy of the universe increased, and we were able to quantify it.
- The adiabatic mixing process we described is irreversible. That is to say, once mixed, we do not expect to see a spontaneous return to the initial state.
- The entropy of the universe will increase whenever two systems, initially not in equilibrium, come to an equilibrium.
- Had the initial states been identical, $T_A = T_B$, $P_A = P_B$, we would have found $T_A = T_B = T_C$ and $P_A = P_B = P_C$ and $\Delta S_A + \Delta S_B = 0$. This is a consequence of both A and B being formed of the same gas that was *indistinguishable* from chamber A to chamber B .

- Had gas A been *distinguishable* from gas B , for example A may have been entirely O_2 and B may have been entirely N_2 , the analysis would be considerably more nuanced. Such an analysis would require the development of a *mixture theory*, not considered here. One would find that even if $T_A = T_B = T_C$ and $P_A = P_B = P_C$, that there would be an *entropy of mixing*, not related to thermo-mechanical effects. This reflects the fact that once mixed, A and B do not spontaneously return to their original unmixed state without external energy input. Such a mixture theory is the foundation for the science of chemistry. The more one is able to distinguish gases, the more one has information about them, and this is related to the entropy. The relation of entropy to information is foundational and discussed in the following section.

The previous example showed the second law was satisfied if the system came to equilibrium because the entropy change was positive for the globally adiabatic problem. Let us turn this around and demonstrate a stronger result: *the equilibrium state is the one that maximizes entropy in an adiabatic mixing problem.*

To do this let us consider a simpler mixing problem: globally adiabatic mixing of the thermal energy of two incompressible, immobile calorically perfect solids, initially with distinct temperatures and thus not in thermal equilibrium. Rather than assert that the temperatures equilibrate, we take a different approach. We consider all the possible final states that satisfy the first law of thermodynamics, and select as the final state the one that maximizes the final entropy of the mixture.

Example 6.17

Consider a chamber that is thermally insulated from its outer surroundings. The chamber is initially divided into two compartments A and B , by a thin, thermally insulated barrier. Both compartments contain the same incompressible solid with identical mass m and identical constant specific heat c . One mass is initially at $T = T_{A1}$, and the other is at $T = T_{B1}$. The thin barrier is removed, and the combined system comes to a new state consistent with energy conservation. Show the state that conserves energy and maximizes entropy is one of thermal equilibrium at the mean temperature $T_{A2} = T_{B2} = (T_{A1} + T_{B1})/2$.

The process is sketched in Fig. 6.31.

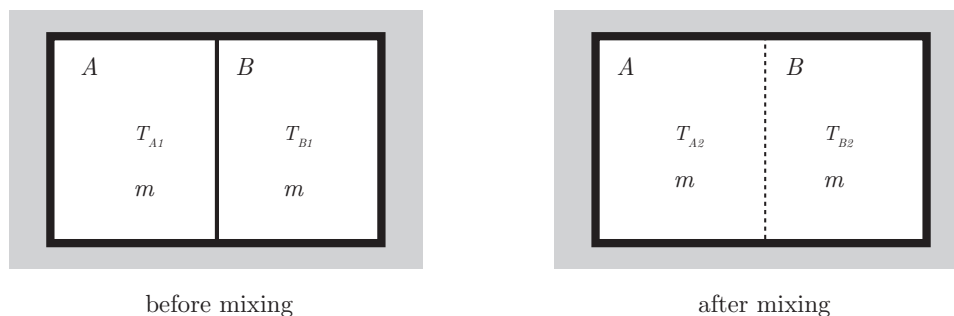

Figure 6.31: Schematic for globally adiabatic thermal mixing problem.

Energy conservation for the mixture requires that

$$U_2 - U_1 = \underbrace{{}_1Q_2}_0 - \underbrace{{}_1W_2}_0, \quad (6.455)$$

$$mc(T_{A2} - T_{A1}) + mc(T_{B2} - T_{B1}) = 0, \quad (6.456)$$

$$(T_{A2} - T_{A1}) + (T_{B2} - T_{B1}) = 0, \quad (6.457)$$

$$(T_{A2} + T_{B2}) - (T_{A1} + T_{B1}) = 0. \quad (6.458)$$

Here we have not enforced temperature equilibrium at state 2. So there are an infinite number of ways to partition the energy at state 2 and still maintain energy conservation. One of those partitions of energy will result in a maximization of mixture entropy. Let us study that.

The entropy change is

$$S_2 - S_1 = mc \ln \frac{T_{A2}}{T_{A1}} + mc \ln \frac{T_{B2}}{T_{B1}}. \quad (6.459)$$

So

$$S_2 = S_1 + mc \ln \frac{T_{A2}}{T_{A1}} + mc \ln \frac{T_{B2}}{T_{B1}}. \quad (6.460)$$

We seek the T_{A2} and T_{B2} that both maximize entropy S_2 and simultaneously satisfy an energy conservation constraint. This is well suited for the method of Lagrange multipliers. Lagrange is depicted in Fig. 6.32. Let us define an auxiliary function S_* as

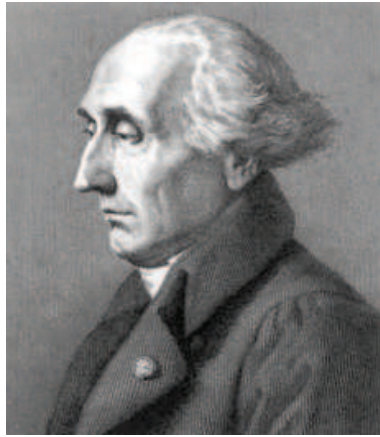

Figure 6.32: Joseph-Louis Lagrange (1736-1813), Franco-Italian mathematician and mechanician; image from https://en.wikipedia.org/wiki/Joseph-Louis_Lagrange.

$$S_* = \underbrace{S_1 + mc \ln \frac{T_{A2}}{T_{A1}} + mc \ln \frac{T_{B2}}{T_{B1}}}_{S_2} - \lambda \underbrace{((T_{A2} + T_{B2}) - (T_{A1} + T_{B1}))}_{=0}. \quad (6.461)$$

The term λ is known as the Lagrange multiplier. The term it multiplies is our energy conservation constraint, which must be zero. So if we maximize S_* , we also maximize S_2 . For S_* to be maximized, its partial derivatives with respect to both T_{A2} and T_{B2} must be zero. The partial derivatives are

$$\frac{\partial S_*}{\partial T_{A2}} = \frac{mc}{T_{A2}} - \lambda, \quad (6.462)$$

$$\frac{\partial S_*}{\partial T_{B2}} = \frac{mc}{T_{B2}} - \lambda. \quad (6.463)$$

Setting both the partial derivatives to zero, and simultaneously enforcing the energy conservation constraint, Eq. (6.458), gives three equations for the three unknowns T_{A2} , T_{B2} , and λ :

$$\frac{mc}{T_{A2}} - \lambda = 0, \quad (6.464)$$

$$\frac{mc}{T_{B2}} - \lambda = 0, \quad (6.465)$$

$$(T_{A2} + T_{B2}) - (T_{A1} + T_{B1}) = 0. \quad (6.466)$$

Subtracting the first from the second and dividing by mc gives

$$\frac{1}{T_{A2}} - \frac{1}{T_{B2}} = 0, \quad (6.467)$$

$$\frac{1}{T_{A2}} = \frac{1}{T_{B2}}, \quad (6.468)$$

$$T_{A2} = T_{B2}. \quad (6.469)$$

The final temperatures that maximize entropy must be equal. Let us apply this result to energy conservation, Eq. (6.458), to see what they are:

$$(T_{A2} + T_{A2}) - (T_{A1} + T_{B1}) = 0, \quad (6.470)$$

$$2T_{A2} = T_{A1} + T_{B1}, \quad (6.471)$$

$$T_{A2} = T_{B2} = \frac{T_{A1} + T_{B1}}{2}. \quad (6.472)$$

For the system we study, the equilibrium temperature is the mean of the original temperatures. Though not particularly important, the Lagrange multiplier is

$$\lambda = \frac{2mc}{T_{A1} + T_{B1}}. \quad (6.473)$$

We can see the mixture entropy maximized, not minimized, via an alternative related analysis. Let us first recast Eq. (6.460) so that it gives a dimensionless scaled mixture entropy change \hat{S} :

$$\hat{S} = \frac{S_2 - S_1}{mc} = \ln \left(\frac{T_{A2} T_{B2}}{T_{A1} T_{B1}} \right). \quad (6.474)$$

Obviously, if S_2 is maximized, so is \hat{S} . Operate further to get

$$T_{A1} T_{B1} e^{\hat{S}} = T_{A2} T_{B2}, \quad (6.475)$$

$$\underbrace{\frac{T_{A1} T_{B1}}{(T_{A1} + T_{B1})^2}}_{\tilde{S}} e^{\hat{S}} = \frac{T_{A2}}{T_{A1} + T_{B1}} \frac{T_{B2}}{T_{A1} + T_{B1}}, \quad (6.476)$$

With $\tilde{S} \equiv T_{A1} T_{B1} e^{\hat{S}} / (T_{A1} + T_{B1})^2$, we see that if we maximize S_2 , we maximize \hat{S} and \tilde{S} . Thus, we have

$$\tilde{S} = \frac{T_{A2}}{T_{A1} + T_{B1}} \frac{T_{B2}}{T_{A1} + T_{B1}}. \quad (6.477)$$

Next invoke energy conservation, Eq. (6.458) to eliminate T_{B2} and yield

$$\tilde{S} = \frac{T_{A2}}{T_{A1} + T_{B1}} \frac{\overbrace{(T_{B1} + T_{A1} - T_{A2})}^{T_{B2}}}{T_{A1} + T_{B1}}, \quad (6.478)$$

$$= \frac{T_{A2}}{T_{A1} + T_{B1}} \left(1 - \frac{T_{A2}}{T_{A1} + T_{B1}} \right). \quad (6.479)$$

With the dimensionless final temperature of A defined as $\hat{T}_{A2} = T_{A2}/(T_{A1} + T_{B1})$, we have

$$\tilde{S} = \hat{T}_{A2}(1 - \hat{T}_{A2}). \quad (6.480)$$

It takes on a critical value when its first derivative is zero:

$$\frac{d\tilde{S}}{d\hat{T}_{A2}} = 1 - 2\hat{T}_{A2} = 0. \quad (6.481)$$

This occurs when

$$\hat{T}_{A2} = \frac{1}{2}, \quad (6.482)$$

$$\frac{T_{A2}}{T_{A1} + T_{B1}} = \frac{1}{2}, \quad (6.483)$$

$$T_{A2} = \frac{T_{A1} + T_{B1}}{2}. \quad (6.484)$$

This is consistent with our result obtained using the method of Lagrange multipliers, Eq. (6.472). The second derivative test reveals the critical point is a maximum because it is negative:

$$\frac{d^2\tilde{S}}{d\hat{T}_{A2}^2} = -2. \quad (6.485)$$

A plot of the scaled entropy \tilde{S} as a function of the scaled final temperature \hat{T}_{A2} is given in Fig. 6.33.

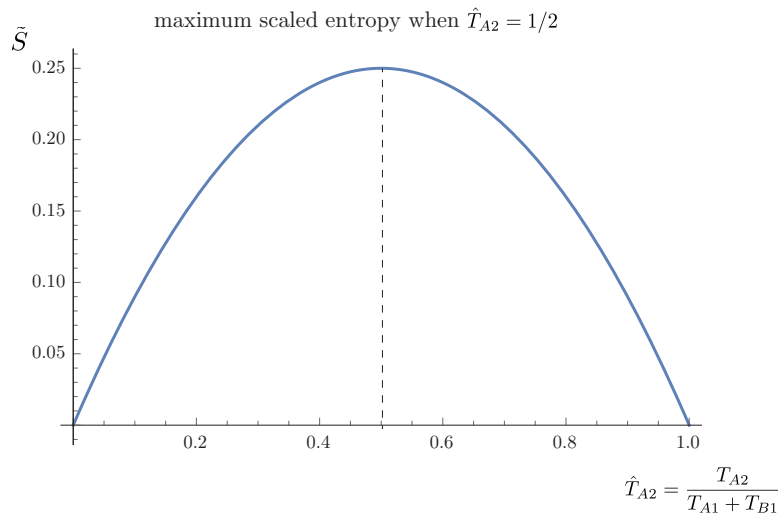
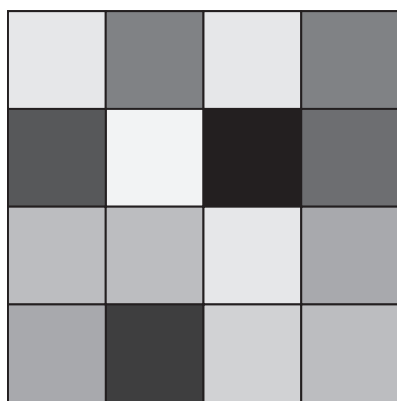

Figure 6.33: Scaled entropy as a function of scaled final temperature for globally adiabatic thermal mixing problem.

6.10 Probabilistic approach to entropy

One of the more difficult concepts regarding entropy is how it relates to the randomness of a system. In fact what constitutes randomness *vis-à-vis* structure may be open to question.

Consider the diagram of Fig. 6.34. Here, we take the level of the grey scale to be propor-



individual blocks at different temperatures: indication of structure, order, and low entropy

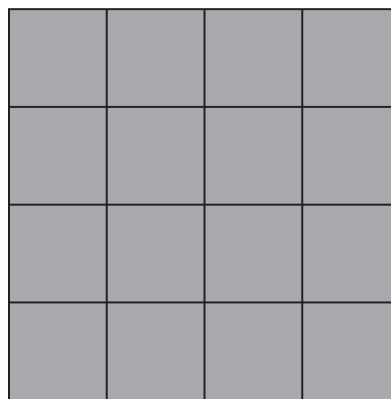

individual blocks at uniform intermediate temperature: indication of lack of structure, randomness, and high entropy

Figure 6.34: Two scenarios for the temperature field with the grey scale proportional to the temperature.

tional to the local temperature. The blocks on the left are held at a variety of temperatures, hot, intermediate, and cold. The blocks on the right are held at the same intermediate temperature. Let us restrict attention to the case where the hot and cold temperature blocks on the left just balance, so that when the net temperature of all the blocks on the left is calculated, it is precisely the intermediate temperature of the blocks on the right. For such a case, the total thermal energy of the left and right configurations is equal. Energy being equal, which configuration has the higher entropy? One is tempted to say that on the left because it looks to be more random. But in fact it is the configuration on the right, that is equivalent to that on the left having come to equilibrium, while conserving energy. The configuration on the left has each block at a different temperature. This is properly considered, in the sense of thermodynamics, to be a structure. Left to itself, the thermal energy would diffuse, giving rise to the configuration on the right. Now, the grey-level of each block on the left is representative of that block's average kinetic energy. Within each block, there will be a distribution of kinetic energy for each individual molecule. For the blocks on the right, there is an overall distribution of randomness, the same for each block. That randomness is not represented by the uniform grey shade, that only captures the average kinetic energy.

It may be possible to better understand the relationship between entropy and randomness, such as that depicted in Fig. 6.34, by the following discussion. Let us consider a radically

different approach to entropy, first advocated by Boltzmann in the late nineteenth century. Boltzmann, depicted at two disparate stages in his life in Fig. 6.35, had to struggle mightily



Figure 6.35: Ludwig Boltzmann (1844-1906), Austrian physicist whose statistical approach to thermodynamics laid the foundation for quantum mechanics; images from <http://mathshistory.st-andrews.ac.uk/Biographies/Boltzmann.html>.

for his theories to gain acceptance in a time when the atomic theory of matter was not widely understood. His arguments have become accepted over time relative to those of his many detractors. Let us define a set of N possible states, each with a probability of p_n . By the nature of probability, we must have

$$\sum_{n=1}^N p_n = 1. \quad (6.486)$$

Because of the nature of probability, we will demand that

$$p_n \in [0, 1]. \quad (6.487)$$

That is to say neither negative probability or probability greater than unity has any meaning. Let us define the entropy of the system according to what has become known as the *Gibbs entropy formula*:

$$S = -k_B \sum_{n=1}^N p_n \ln p_n. \quad (6.488)$$

where we take k_B to be the *Boltzmann constant*. Boltzmann's tomb has a variant of this equation cut into its stone, as shown in Fig. 6.35. As an aside, we note that operating on

Eq. (6.488) yields an alternative expression relating S to p_n :

$$-\frac{S}{k_B} = \sum_{n=1}^N p_n \ln p_n, \quad (6.489)$$

$$-\frac{S}{k_B} = \sum_{n=1}^N \ln p_n^{p_n}, \quad (6.490)$$

$$-\frac{S}{k_B} = \ln \prod_{n=1}^N p_n^{p_n}, \quad (6.491)$$

$$\exp\left(-\frac{S}{k_B}\right) = \prod_{n=1}^N p_n^{p_n}. \quad (6.492)$$

Boltzmann defined k_B such that

$$k_B \equiv \frac{\bar{R}}{\mathcal{N}}, \quad (6.493)$$

where \mathcal{N} is Avogadro's number, $\mathcal{N} = 6.02214179 \times 10^{23}$ molecule/mole. So

$$k_B = \frac{8.314472 \frac{\text{J}}{\text{K mole}}}{6.02214179 \times 10^{23} \frac{\text{molecule}}{\text{mole}}} = 1.380650 \times 10^{-23} \frac{\text{J}}{\text{K molecule}}. \quad (6.494)$$

Example 6.18

Consider a CPIG in terms of the Boltzmann constant.

We have

$$PV = n\bar{R}T, \quad (6.495)$$

$$= n\frac{\mathcal{N}}{\mathcal{N}}\bar{R}T, \quad (6.496)$$

$$= n\mathcal{N} \underbrace{\frac{\bar{R}}{\mathcal{N}}}_{=k_B} T, \quad (6.497)$$

$$= \underbrace{n\mathcal{N}}_{\mathbf{N}} k_B T. \quad (6.498)$$

We next define the number of molecules \mathbf{N} as the product of the number of moles, that we have taken to be n , and the number of molecules per mole, \mathcal{N} :

$$\mathbf{N} = n\mathcal{N}. \quad (6.499)$$

Thus, the ideal gas law becomes

$$PV = \mathbf{N}k_B T. \quad (6.500)$$

Consider next the internal energy. Neglecting the additive constant, we have

$$u = c_v T. \quad (6.501)$$

Now, scale by the molecular mass to cast this on a per mole basis:

$$\frac{u}{M} = \frac{c_v}{M}T, \quad (6.502)$$

$$\bar{u} = \bar{c}_v T, \quad (6.503)$$

$$\bar{u} = \frac{\bar{c}_v}{R} \bar{R}T, \quad (6.504)$$

$$\bar{u} = \frac{\bar{c}_v}{\bar{c}_P - \bar{c}_v} \bar{R}T, \quad (6.505)$$

$$\bar{u} = \frac{1}{\frac{\bar{c}_P}{\bar{c}_v} - 1} \bar{R}T, \quad (6.506)$$

$$\bar{u} = \frac{1}{k-1} \bar{R}T, \quad (6.507)$$

$$\bar{u} = \frac{\mathcal{N}}{k-1} \frac{\bar{R}}{\mathcal{N}} T, \quad (6.508)$$

$$\bar{u} = \frac{\mathcal{N}}{k-1} k_B T, \quad (6.509)$$

$$\frac{\bar{u}}{\mathcal{N}} = \frac{1}{k-1} k_B T. \quad (6.510)$$

Now, \bar{u} is the energy per mole. And \mathcal{N} is the number of molecules per mole. Now, define \hat{u} as the energy per molecule:

$$\hat{u} = \frac{\bar{u}}{\mathcal{N}}. \quad (6.511)$$

Thus,

$$\hat{u} = \frac{1}{k-1} k_B T, \quad (6.512)$$

$$\left[\frac{\text{J}}{\text{molecule}} \right] = \left[\frac{\text{J}}{\text{K molecule}} \right] [\text{K}]. \quad (6.513)$$

For a monatomic ideal gas, $k = 5/3$; therefore,

$$\hat{u} = \frac{3}{2} k_B T. \quad (6.514)$$

For monatomic ideal gases, there are three degrees of freedom, one for each of the three dimensions available for motion, x , y , z ; thus, each degree of freedom contributes $(1/2)k_B T$ to the internal energy of the molecule.

Example 6.19

Consider a system with four possible states, 1, 2, 3, and 4. Now, consider three configurations A , B , and C . For each configuration, that may correspond to a bulk energy level, we have a different set of probabilities for each state. Let us take:

- Energy level A : $p_1 = 1$, $p_2 = 0$, $p_3 = 0$, $p_4 = 0$.
- Energy level B : $p_1 = \frac{1}{2}$, $p_2 = \frac{1}{4}$, $p_3 = \frac{1}{8}$, $p_4 = \frac{1}{8}$.

| Roll | p_n | $-k_B p_n \ln p_n$ |
|-------|----------------|-------------------------------------|
| 2 | 1/36 | 0.0995 k_B |
| 3 | 2/36 | 0.1605 k_B |
| 4 | 3/36 | 0.2071 k_B |
| 5 | 4/36 | 0.2441 k_B |
| 6 | 5/36 | 0.2742 k_B |
| 7 | 6/36 | 0.2986 k_B |
| 8 | 5/36 | 0.2742 k_B |
| 9 | 4/36 | 0.2441 k_B |
| 10 | 3/36 | 0.2071 k_B |
| 11 | 2/36 | 0.1605 k_B |
| 12 | 1/36 | 0.0995 k_B |
| Total | $\sum p_n = 1$ | $-k_B \sum p_n \ln p_n = 2.2694k_B$ |

Table 6.4: Entropy associated with an ordinary pair of six-sided unbiased dice.

- Energy level C : $p_1 = \frac{1}{4}$, $p_2 = \frac{1}{4}$, $p_3 = \frac{1}{4}$, $p_4 = \frac{1}{4}$.

Find the entropy of each energy level via $S = -k_B \sum_{n=1}^4 p_n \ln p_n$.

- A : $S_A = -k_B (1 \ln 1 + 0 \ln 0 + 0 \ln 0 + 0 \ln 0) = 0$.
- B : $S_B = -k_B \left(\frac{1}{2} \ln \frac{1}{2} + \frac{1}{4} \ln \frac{1}{4} + \frac{1}{8} \ln \frac{1}{8} + \frac{1}{8} \ln \frac{1}{8} \right) = 1.21301k_B$.
- C : $S_C = -k_B \left(\frac{1}{4} \ln \frac{1}{4} + \frac{1}{4} \ln \frac{1}{4} + \frac{1}{4} \ln \frac{1}{4} + \frac{1}{4} \ln \frac{1}{4} \right) = 1.38629k_B$.

Note the least random is at energy level A , where there is certainty that the configuration is state 1. There is no randomness to this, and the entropy is formally zero. Loosely speaking, this might correspond to a temperature of absolute zero, where the probability of finding a molecule in its ground state is unity. Note that we have used the mathematical limit $\lim_{x \rightarrow 0} x \ln x = 0$, that can be shown with l'Hôpital's rule. Configuration B is less random, with some bias towards states 1 and 2. It has positive entropy. Configuration C has the highest entropy. In this configuration, all states are equally likely. It is the most random in this sense.

Example 6.20

Let us do the same exercise with a pair of ordinary dice.

We summarize the probability of rolling each number in Table 6.4. The entropy of this configuration is $S = 2.2694k_B$. Now, if each roll were equally likely, the entropy would be different. We would need a single die with eleven sides to achieve this! See Table 6.5. The entropy of this configuration is greater, and in fact, maximum: $S = 2.3979k_B$.

| Roll | p_n | $-k_B p_n \ln p_n$ |
|-------|----------------|-------------------------------------|
| 2 | 1/11 | $0.21799k_B$ |
| 3 | 1/11 | $0.21799k_B$ |
| 4 | 1/11 | $0.21799k_B$ |
| 5 | 1/11 | $0.21799k_B$ |
| 6 | 1/11 | $0.21799k_B$ |
| 7 | 1/11 | $0.21799k_B$ |
| 8 | 1/11 | $0.21799k_B$ |
| 9 | 1/11 | $0.21799k_B$ |
| 10 | 1/11 | $0.21799k_B$ |
| 11 | 1/11 | $0.21799k_B$ |
| 12 | 1/11 | $0.21799k_B$ |
| Total | $\sum p_n = 1$ | $-k_B \sum p_n \ln p_n = 2.3979k_B$ |

Table 6.5: Entropy of an equally weighted eleven-sided die.

Example 6.21

Consider the entropy associated with the results of rolling an ordinary unbiased six-sided die. Compare this with a variety of biased or so-called “loaded” die.

First consider the unbiased or non-“loaded” die. The probability of rolling each number 1 through 6 is $p_n = 1/6$. The entropy associated with each roll is $-k_B p_n \ln p_n = -k_B(1/6) \ln(1/6) = 0.298627k_B$. See Table 6.6. The total entropy is

$$S = -k_B \sum_{n=1}^6 p_n \ln p_n = 1.79176k_B. \quad (6.515)$$

Now, consider the average value of a roll of the die. A given roll will result in a value of $n = 1, \dots, 6$. Let us define the average value of n to be $\langle n \rangle$. Using the ordinary rules of probability, we expect that

$$\langle n \rangle = \sum_{n=1}^6 n p_n = 1 \left(\frac{1}{6}\right) + 2 \left(\frac{1}{6}\right) + 3 \left(\frac{1}{6}\right) + 4 \left(\frac{1}{6}\right) + 5 \left(\frac{1}{6}\right) + 6 \left(\frac{1}{6}\right) = \frac{7}{2}. \quad (6.516)$$

Let us turn our analysis around. Let us say we know $\langle n \rangle = 7/2$, but do not know p_n . Thermodynamically, this is equivalent to saying we know the mean kinetic energy of our molecules, but do not know the kinetic energy of an individual molecule. Given that there are six possible states of the system, we would like to know how this energy is distributed among the possible states. Now, we already know that $p_n = 1/6$ for $n = 1, \dots, 6$ is a possibility. But it is easy to check that $p_3 = p_4 = 1/2$, $p_1 = p_2 = p_5 = p_6 = 0$ is another possibility. In fact, there are an infinite set of p_n for which $\sum_{n=1}^6 p_n = 1$ and $\sum_{n=1}^6 n p_n = 7/2$. To fix our selection of the distribution of p_n , let us assert that the entropy is maximized, while simultaneously satisfying the two constraints $\sum_{n=1}^6 p_n = 1$ and $\sum_{n=1}^6 n p_n = 7/2$.

This gives rise to a problem in constrained optimization, that can be solved with the method of Lagrange multipliers. Thus, our problem is to select p_n so as to maximize

$$S^* = -k_B \sum_{n=1}^6 p_n \ln p_n + \lambda_1 \left(1 - \sum_{n=1}^6 p_n\right) + \lambda_2 \left(\frac{7}{2} - \sum_{n=1}^6 n p_n\right), \quad (6.517)$$

| Roll | p_n | $-k_B p_n \ln p_n$ |
|-------|----------------|--------------------------------------|
| 1 | 1/6 | 0.298627 k_B |
| 2 | 1/6 | 0.298627 k_B |
| 3 | 1/6 | 0.298627 k_B |
| 4 | 1/6 | 0.298627 k_B |
| 5 | 1/6 | 0.298627 k_B |
| 6 | 1/6 | 0.298627 k_B |
| Total | $\sum p_n = 1$ | $-k_B \sum p_n \ln p_n = 1.79176k_B$ |

Table 6.6: Entropy of an equally weighted six-sided die.

subject to the constraints

$$\sum_{n=1}^6 p_n = 1, \quad (6.518)$$

$$\sum_{n=1}^6 np_n = \frac{7}{2}. \quad (6.519)$$

Here $S^* = S + \lambda_1 \left(1 - \sum_{n=1}^6 p_n\right) + \lambda_2 \left(7/2 - \sum_{n=1}^6 np_n\right)$, and λ_1 and λ_2 are the Lagrange multipliers. If we maximize S^* , while satisfying the constraints, we also maximize S . To obtain a solution for values of p_n that maximize S^* , we differentiate Eq. (6.517) with respect to each p_n and set the result to zero. We thus get six equations:

$$\frac{\partial S^*}{\partial p_1} = -k_B (1 + \ln p_1) - \lambda_1 - \lambda_2 = 0, \quad (6.520)$$

$$\frac{\partial S^*}{\partial p_2} = -k_B (1 + \ln p_2) - \lambda_1 - 2\lambda_2 = 0, \quad (6.521)$$

$$\frac{\partial S^*}{\partial p_3} = -k_B (1 + \ln p_3) - \lambda_1 - 3\lambda_2 = 0, \quad (6.522)$$

$$\frac{\partial S^*}{\partial p_4} = -k_B (1 + \ln p_4) - \lambda_1 - 4\lambda_2 = 0, \quad (6.523)$$

$$\frac{\partial S^*}{\partial p_5} = -k_B (1 + \ln p_5) - \lambda_1 - 5\lambda_2 = 0, \quad (6.524)$$

$$\frac{\partial S^*}{\partial p_6} = -k_B (1 + \ln p_6) - \lambda_1 - 6\lambda_2 = 0. \quad (6.525)$$

These six equations take the general form

$$-k_B(1 + \ln p_n) - \lambda_1 - n\lambda_2 = 0, \quad n = 1, \dots, 6, \quad (6.526)$$

that reduces to

$$\ln p_n = -1 - \frac{\lambda_1}{k_B} - \frac{\lambda_2}{k_B}n, \quad (6.527)$$

$$p_n = \exp\left(-1 - \frac{\lambda_1}{k_B} - \frac{\lambda_2}{k_B}n\right), \quad (6.528)$$

$$p_n = \exp\left(-1 - \frac{\lambda_1}{k_B}\right) \exp\left(-n \frac{\lambda_2}{k_B}\right). \quad (6.529)$$

These six equations, embodied in Eq. (6.529), in conjunction with the two constraints, Eqs. (6.518,6.519), form eight equations for the eight unknowns $p_1, \dots, p_6, \lambda_1/k_B, \lambda_2/k_B$. They can be solved iteratively by Newton's method. We find

$$\langle n \rangle = \frac{7}{2} : \quad p_1 = p_2 = p_3 = p_4 = p_5 = p_6 = \frac{1}{6}. \quad (6.530)$$

From here on let us take $\lambda_1^* = \lambda_1/k_B$ and $\lambda_2^* = \lambda_2/k_B$. The values of the Lagrange multipliers are $\lambda_1^* = 0.79176$, $\lambda_2^* = 0$, but are not of particular importance. One could use a variety of methods to show the extreme value for S we found was actually a maximum. Thus, for $\langle n \rangle = 7/2$, the probability distribution function that maximizes entropy is in fact uniform, with $p_n = 1/6$. Thermodynamically, this implies that if the average energy is $7/2$, the six accessible states are equally likely to be populated,

as it is this distribution of probabilities that maximizes the system's entropy and thus satisfies the second law of thermodynamics.

Let us decrease the mean die roll to $\langle n \rangle = 2$ and ask what probability distribution now maximizes entropy. That is to say, we are going to employ a "loaded" die. Now, there are again an infinite number of ways to distribute p_n to obtain $\langle n \rangle = 2$. One obvious way is to take $p_2 = 1$ and $p_1 = p_3 = p_4 = p_5 = p_6 = 0$. But this will not maximize entropy; certainly, such a die has no randomness to it. Replacing Eq. (6.519) with $\sum_{n=1}^6 np_n = 2$ and solving the similar Lagrange multipliers problem to determine the set of p_n that maximizes S , we obtain

$$\langle n \rangle = 2 : \quad p_1 = 0.47812, \quad (6.531)$$

$$p_2 = 0.254752, \quad (6.532)$$

$$p_3 = 0.135737, \quad (6.533)$$

$$p_4 = 0.0723234, \quad (6.534)$$

$$p_5 = 0.0385354, \quad (6.535)$$

$$p_6 = 0.0205324. \quad (6.536)$$

A die loaded in this fashion will maximize entropy or randomness while simultaneously achieving the desired average behavior, that can be thought of as conserving energy.

If we choose a mildly loaded die, so that $\langle n \rangle = 4$, we find the distribution of p_n that maximizes entropy to be slightly biased:

$$\langle n \rangle = 4 : \quad p_1 = 0.103065, \quad (6.537)$$

$$p_2 = 0.122731, \quad (6.538)$$

$$p_3 = 0.146148, \quad (6.539)$$

$$p_4 = 0.174034, \quad (6.540)$$

$$p_5 = 0.207240, \quad (6.541)$$

$$p_6 = 0.246782. \quad (6.542)$$

The probability distribution functions $p_n(n)$ for a variety of $\langle n \rangle$ values are shown in Fig. 6.36. Obviously, if $\langle n \rangle = 1$, there is only one possibility: the die must be entirely weighted to always yield a 1; thus, $p_1 = 1$, and all others are zero. There is no randomness, and the entropy is zero. A similar condition holds for $\langle n \rangle = 6$. For $\langle n \rangle \in [1, 6]$, there is a non-trivial distribution of p_n that maximizes S for the given $\langle n \rangle$. Note that when $\langle n \rangle = 7/2$, that S is maximized, and the probability distribution is uniform with $p_n = 1/6$. A plot of S/k_B versus $\langle n \rangle$ is given in Fig. 6.37.

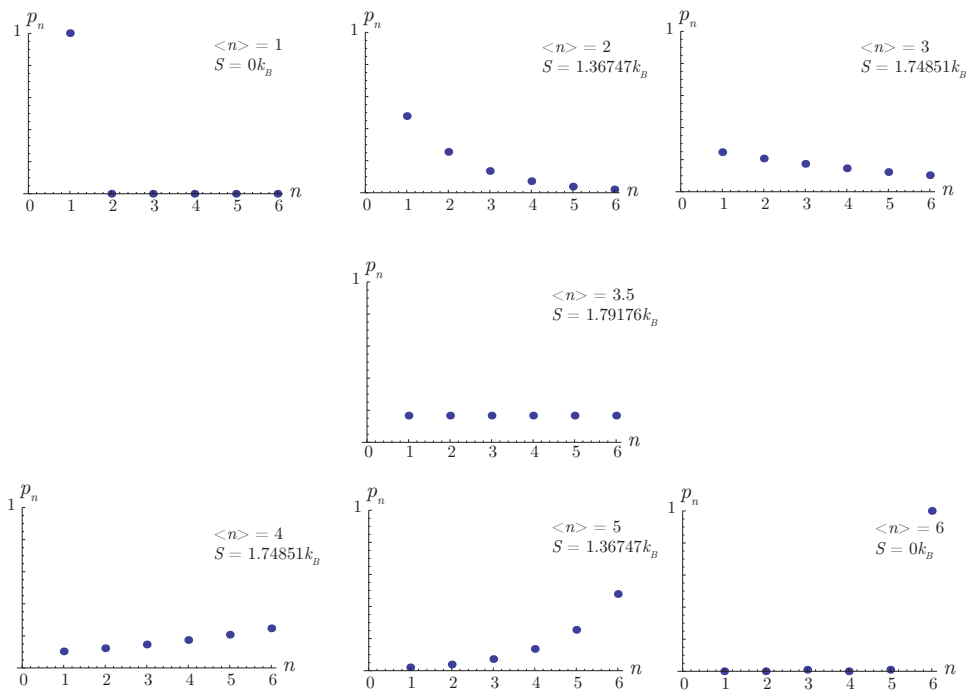

Figure 6.36: Probability distribution functions for a six-sided die weighted so as to achieve a variety of mean values $\langle n \rangle = 1, 2, 3, 7/2, 4, 5, 6$ while maximizing entropy.

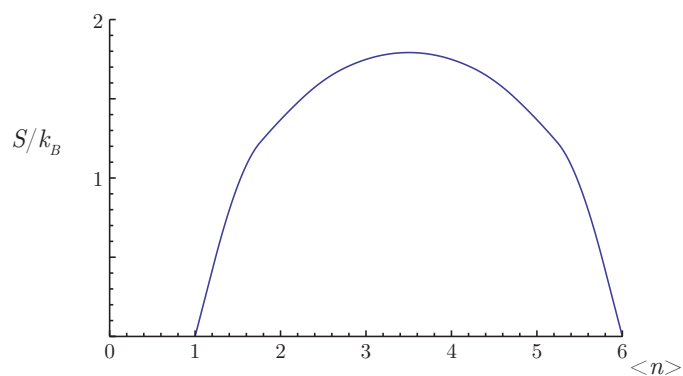

Figure 6.37: Scaled entropy as a function of mean value of the six-sided die.

As an aside, let us reconsider Eq. (6.529), that itself holds for any value of $\langle n \rangle$. Because $\sum_{n=1}^6 p_n = 1$, we can form

$$\sum_{n=1}^6 p_n = 1 = \exp(-1 - \lambda_1^*) \sum_{n=1}^6 \exp(-n\lambda_2^*). \quad (6.543)$$

Now, let us divide Eq. (6.529) by the left and right sides of Eq. (6.543) so as to get

$$p_n = \frac{\exp(-n\lambda_2^*)}{\sum_{n=1}^6 \exp(-n\lambda_2^*)}. \quad (6.544)$$

We next define the so-called *partition function*, $Z(\lambda_2^*)$, as

$$Z(\lambda_2^*) = \sum_{n=1}^6 \exp(-n\lambda_2^*). \quad (6.545)$$

Now, rewriting Eq. (6.527), we have

$$\ln p_n = -1 - \lambda_1^* - n\lambda_2^*. \quad (6.546)$$

Now, take the logarithm of Eq. (6.544) and employ the definition of the partition function, Eq. (6.545), to get

$$\ln p_n = -n\lambda_2^* - \ln Z. \quad (6.547)$$

Combining Eqs. (6.546) and (6.547), we get

$$1 + \lambda_1^* = \ln Z. \quad (6.548)$$

This relates the first Lagrange multiplier to the second, that is embodied within Z .

Now, let us uncover a non-obvious, but useful relation through the following sequence of operations. Let us prove that

$$\langle n \rangle = -\frac{d}{d\lambda_2^*} \ln Z. \quad (6.549)$$

We can show this by employing our definitions combined with a series of operations and see if we are led to an identity. First use the chain rule

$$\langle n \rangle = -\frac{dZ}{d\lambda_2^*} \frac{d}{dZ} \ln Z, \quad (6.550)$$

$$= -\frac{dZ}{d\lambda_2^*} \frac{1}{Z}, \quad (6.551)$$

$$= \left(-\frac{d}{d\lambda_2^*} \sum_{n=1}^6 \exp(-n\lambda_2^*) \right) \frac{1}{Z}, \quad (6.552)$$

$$= \left(\sum_{n=1}^6 n \exp(-n\lambda_2^*) \right) \frac{1}{Z}, \quad (6.553)$$

$$= \frac{\sum_{n=1}^6 n \exp(-n\lambda_2^*)}{\sum_{n=1}^6 \exp(-n\lambda_2^*)}. \quad (6.554)$$

Now, we also know by definition of the average and the probability p_n that

$$\langle n \rangle = \sum_{n=1}^6 n p_n. \quad (6.555)$$

Using Eq. (6.544) to remove p_n from Eq. (6.555), we recover exactly Eq. (6.554). Thus our assertion of Eq. (6.549) is true.

Lastly, we see that given $\langle n \rangle$, it is possible to solve Eq. (6.554) to find λ_2^* . With λ_2^* , one can then use Eq. (6.544) to find each of the p_n . In fact, the problem reduces to solving a polynomial equation. If we take $x = \exp(-\lambda_2^*)$, Eq. (6.554) reduces to

$$\langle n \rangle = \frac{x + 2x^2 + 3x^3 + 4x^4 + 5x^5 + 6x^6}{x + x^2 + x^3 + x^4 + x^5 + x^6}. \quad (6.556)$$

A factor of x cancels, and after rearrangement, we find a fifth order polynomial in x :

$$(6 - \langle n \rangle)x^5 + (5 - \langle n \rangle)x^4 + (4 - \langle n \rangle)x^3 + (3 - \langle n \rangle)x^2 + (2 - \langle n \rangle)x + (1 - \langle n \rangle) = 0. \quad (6.557)$$

There are five roots to this equation, and at least one real root. It is likely possible to prove that in cases of interest there is only one real root. Let us check for the special case in which $\langle n \rangle = 3.5 = 7/2$. In that case, we get

$$5x^5 + 3x^4 + x^3 - x^2 - 3x - 5 = 0, \quad (6.558)$$

$$(x - 1)(5x^4 + 8x^3 + 9x^2 + 8x + 5) = 0. \quad (6.559)$$

There is obviously one real root, $x = 1$. The other four roots are complex. For $x = \exp(-\lambda_2^*) = 1$, we must have $\lambda_2^* = 0$, as we have seen to be the case for the uniform distribution $p_n = 1/6$ associated with $\langle n \rangle = 7/2$.

Unaware of Boltzmann's theory, electrical engineer and mathematician Claude Shannon published in 1948 what amounts to precisely the same theory in the context of data communication. He arrived at a similar formula as Gibbs for the so-called *information entropy*, $S_{information}$:

$$S_{information} = - \sum_{n=1}^N p_i \ln p_i. \quad (6.560)$$

This is effectively a dimensionless version of the Gibbs entropy function, Eq. (6.488), differing only by a factor of k_B . When applied in such context, Boltzmann's theory is known as *information theory*. Information theory was constructed to quantify data lost in telephone line signals. The theory and its author has had a seminal effect on modern computer and communication technologies.^{11,12} Shannon as well as scenes from a public park dedicated to him in his hometown of Gaylord, Michigan, is depicted in Fig. 6.38.

¹¹C. E. Shannon, 1948, "A mathematical theory of communication," *Bell System Technical Journal*, 27(3): 379-423.

¹²C. E. Shannon, 1948, "A mathematical theory of communication," *Bell System Technical Journal*, 27(4): 623-656.



Figure 6.38: Claude Elwood Shannon (1916-2001), American electrical engineer and mathematician whose “information entropy” is mathematically identical to Boltzmann’s statistical definition of entropy; leftmost image from https://en.wikipedia.org/wiki/Claude_Elwood_Shannon.

6.11 Summary statement of thermodynamics

We have now covered the major ideas of the natural philosophy that is thermodynamics. We can summarize for an *isolated* universe by stating

- THE ENERGY OF THE UNIVERSE IS CONSTANT, AND ITS ENTROPY IS INCREASING.

This is a loose translation of the statement of Clausius,¹³

- *Die Energie der Welt ist konstant. Die Entropie der Welt strebt einem Maximum zu.*

It is a pessimistic set of principles! Thinking cosmologically, these laws would suggest that a large concentrated mass-energy complex, initially in a highly structured state, would ultimately deteriorate into spatially homogeneous space dust at a state of final equilibrium, the so-called *heat death* scenario posed initially in the nineteenth century by Kelvin and others. Present non-equilibrium thermodynamic theory would admit local structures to self-organize into ordered units such as a solar system or living beings. Such structures could potentially draw the energy necessary for self-organization from residual energy from the initial state.

Though some disagree, it is claimed here that the science of thermodynamics is incapable of definitively answering theological questions that often arise regarding the origin of the universe, its ultimate fate, and the evolution of structures within it. It simply gives a framework for what is admissible with a given set of assumptions. In that it can illuminate some aspects of theology by identifying those parts of it that are in and out of agreement with

¹³R. Clausius, 1865, “Ueber verschiedene für die Anwendung bequeme Formen der Hauptgleichungen der mechanischen Wärmetheorie,” *Annalen der Physik und Chemie*, 125(7): 353-390.

empirical observations and their consequences, it may be of some use to such disciplines that are outside its realm. More generally, many scientists follow the train of thought popularized by the Austrian philosopher of science Karl Popper (1902-1994) who restricted scientific theories to those that are empirically testable, or more specifically, “falsifiable.” Statements need not be falsifiable to be true, that thus admits the possibility of theological fact; they simply are not science.

So, *if* our universe is formally isolated, we can look forward to “heat death” and the ultimate equilibrium, first suggested by Thomson.¹⁴ *If* it is not isolated, there is more uncertainty, and perhaps less reason for pessimism. The so-called laws of thermodynamics are simply an efficient reflection of present-day empirical data. Science is in that sense radically pragmatic; if unimpeachable data is found that contradict our present axioms of thermodynamics, science resorts to new and improved axioms.

¹⁴W. Thomson, 1852, “On a universal tendency in nature to the dissipation of mechanical energy,” *Transactions of the Royal Society of Edinburgh*, 20(3): 139-142.

Chapter 7

Second law analysis for a control volume

Read BS, Chapter 7

In this chapter, we will apply notions from control volume analysis to problems that involve the second law of thermodynamics. Recall that the fundamental description of our axioms is written for systems. We simply modify these axioms when applying them to control volumes. We shall omit most of the details of the reduction of the second law to control volume formulation. It is not unlike that done for mass and energy conservation.

7.1 Irreversible entropy production

First recall an important form of the second law for a system, Eq. (6.31):

$$S_2 - S_1 \geq \int_1^2 \frac{\delta Q}{T}. \quad (7.1)$$

Let us introduce a convenient variable, the

- **IRREVERSIBLE ENTROPY PRODUCTION:** a quantity that characterizes that portion of entropy production that is irreversible.

We note that entropy can be produced by reversible heat transfer as well, that we segregate and do not consider here. We adopt the common notation of ${}_1\sigma_2$ for irreversible entropy production, with units of kJ/K. Our ${}_1\sigma_2$ is equivalent to ${}_1S_{2\ gen}$ of Eq. (7.11) of BS (p. 283), but is more aligned with the notation of non-equilibrium thermodynamics. We give it the subscripts to emphasize that it is path-dependent. Mathematically, we recast the second law for a system by the following two equations:

$$S_2 - S_1 = \int_1^2 \frac{\delta Q}{T} + {}_1\sigma_2, \quad (7.2)$$

$${}_1\sigma_2 \geq 0. \quad (7.3)$$

Clearly, this is just a notational convenience that moves the inequality from one equation to another. On a differential basis, we can say for a system

$$dS = \frac{\delta Q}{T} + \delta\sigma. \quad (7.4)$$

And for time-dependent processes, we say for a system

$$\frac{dS}{dt} = \frac{1}{T} \frac{\delta Q}{dt} + \frac{\delta\sigma}{dt}. \quad (7.5)$$

Now, let us expand to an unsteady control volume, that should be similar to that for a system, with corrections for inlets and exits. We get

$$\frac{dS_{cv}}{dt} = \sum_j \frac{\dot{Q}_j}{T_j} + \sum_i \dot{m}_i s_i - \sum_e \dot{m}_e s_e + \dot{\sigma}_{cv}. \quad (7.6)$$

Our irreversible entropy production rate, $\dot{\sigma}_{cv}$, with units of kW/K, is equivalent to \dot{S}_{gen} of Eq. (7.10) of BS (p. 283).

Let us study this equation in some common limits. First, if the problem is in steady state, then

$$0 = \sum_j \frac{\dot{Q}_j}{T_j} + \sum_i \dot{m}_i s_i - \sum_e \dot{m}_e s_e + \dot{\sigma}_{cv}, \quad (7.7)$$

steady state limit.

If it is in steady state and there is one entrance and one exit, then mass conservation gives $\dot{m}_i = \dot{m}_e = \dot{m}$, and

$$0 = \sum_j \frac{\dot{Q}_j}{T_j} + \dot{m}(s_i - s_e) + \dot{\sigma}_{cv}, \quad (7.8)$$

steady state, one entrance, one exit.

We can rearrange to say

$$s_e - s_i = \frac{1}{\dot{m}} \sum_j \frac{\dot{Q}_j}{T_j} + \frac{\dot{\sigma}_{cv}}{\dot{m}}. \quad (7.9)$$

If there is no heat transfer to the control volume, then

$$s_e - s_i = \frac{\dot{\sigma}_{cv}}{\dot{m}}, \quad (7.10)$$

no heat transfer to control volume, steady state, one entrance/exit.

Example 7.1

Let us revisit an earlier example problem from p. 193 involving throttling and find the irreversible entropy production flux. Consider calorically perfect ideal air flowing in a duct at $P_1 = 100000$ Pa, $T_1 = 300$ K, $v_1 = 10$ m/s. Take $c_P = 1000$ J/kg/K. The air is throttled down by a valve to $P_2 = 90000$ Pa.

We first repeat some of the earlier analysis. From the ideal gas law we get

$$\rho_1 = \frac{P_1}{RT_1} = \frac{100000 \text{ Pa}}{\left(287 \frac{\text{J}}{\text{kg K}}\right) (300 \text{ K})} = 1.16144 \frac{\text{kg}}{\text{m}^3}. \quad (7.11)$$

We write the mass, energy, thermal and caloric state equations as

$$\rho_2 v_2 = \rho_1 v_1, \quad (7.12)$$

$$h_2 + \frac{v_2^2}{2} = h_1 + \frac{v_1^2}{2}, \quad (7.13)$$

$$P_2 = \rho_2 R T_2, \quad (7.14)$$

$$h_2 - h_1 = c_P (T_2 - T_1). \quad (7.15)$$

This simplifies somewhat to

$$\rho_2 v_2 = \rho_1 v_1, \quad (7.16)$$

$$c_P T_2 + \frac{v_2^2}{2} = c_P T_1 + \frac{v_1^2}{2}, \quad (7.17)$$

$$P_2 = \rho_2 R T_2. \quad (7.18)$$

Substituting numbers, we get the system of non-linear algebraic equations

$$\rho_2 v_2 = \left(1.16144 \frac{\text{kg}}{\text{m}^3}\right) \left(10 \frac{\text{m}}{\text{s}}\right) = 11.6144 \frac{\text{kg}}{\text{m}^2 \text{ s}}, \quad (7.19)$$

$$\left(1000 \frac{\text{J}}{\text{kg K}}\right) T_2 + \frac{v_2^2}{2} = \left(1000 \frac{\text{J}}{\text{kg K}}\right) (300 \text{ K}) + \frac{\left(10 \frac{\text{m}}{\text{s}}\right)^2}{2} = 300050 \frac{\text{J}}{\text{kg}}, \quad (7.20)$$

$$90000 \text{ Pa} = \rho_2 \left(287 \frac{\text{J}}{\text{kg K}}\right) T_2. \quad (7.21)$$

This forms three equations in the three unknowns ρ_2, T_2, v_2 . Detailed manipulation can reduce this to a quadratic equation, with two roots. The first root yields

$$\rho_2 = 1.04533 \frac{\text{kg}}{\text{m}^3}, \quad (7.22)$$

$$T_2 = 299.988 \text{ K}, \quad (7.23)$$

$$v_2 = 11.1107 \frac{\text{m}}{\text{s}}. \quad (7.24)$$

This is the physical root. From Eq. (6.87), we have

$$s_2 - s_1 = c_P \ln \frac{T_2}{T_1} - R \ln \frac{P_2}{P_1}, \quad (7.25)$$

$$= \underbrace{\left(1000 \frac{\text{J}}{\text{kg K}}\right) \ln \frac{299.988 \text{ K}}{300 \text{ K}}}_{-0.0390793 \text{ J/kg/K}} - \underbrace{\left(287 \frac{\text{J}}{\text{kg K}}\right) \ln \frac{90000 \text{ Pa}}{100000 \text{ Pa}}}_{-30.2385 \text{ J/kg/K}}, \quad (7.26)$$

$$= 30.1994 \frac{\text{J}}{\text{kg K}}. \quad (7.27)$$

We can specialize Eq. (7.10) to say

$$\frac{\dot{\sigma}_{cv}}{\dot{m}} = s_2 - s_1, \quad (7.28)$$

$$\frac{\dot{\sigma}_{cv}}{A} = \rho_1 v_1 (s_2 - s_1), \quad (7.29)$$

$$= \left(1.16144 \frac{\text{kg}}{\text{m}^3} \right) \left(10 \frac{\text{m}}{\text{s}} \right) \left(30.1994 \frac{\text{J}}{\text{kg K}} \right), \quad (7.30)$$

$$= 350.748 \frac{\text{W}}{\text{m}^2 \text{K}}. \quad (7.31)$$

As required by the second law, this is a positive quantity. Note that because all the entropy change is associated with irreversibility, and none with heat transfer, the area under the curve on a $T - s$ diagram, while non-zero, does not represent any heat transfer. One could say

- If there is reversible heat transfer, there will be area under the curve in a $T - s$ diagram.
- If there is area under a curve in a $T - s$ diagram, it could be due to either irreversibility or heat transfer.

Example 7.2

A steam turbine has an inlet condition of $P_1 = 30$ bar, $T_1 = 400$ °C, $v_1 = 160$ m/s. Its exhaust condition is $T_2 = 100$ °C, $v_2 = 100$ m/s, $x_2 = 1$. The work for the turbine is $w_{cv} = 540$ kJ/kg. Find $\dot{\sigma}_{cv}/\dot{m}$. The surroundings are at 500 K. See Fig. 7.1.

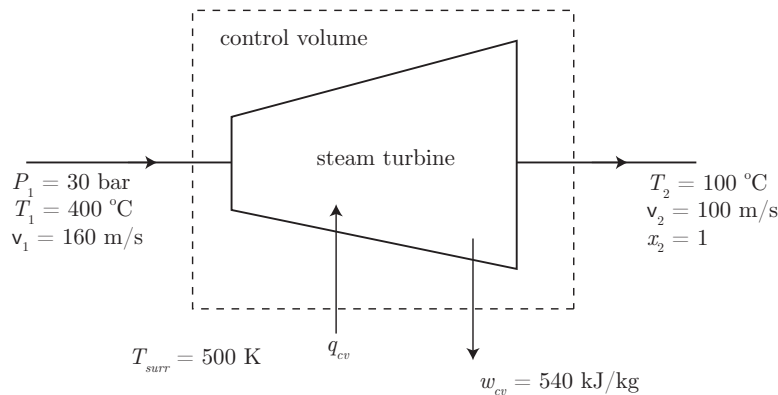

Figure 7.1: Steam turbine schematic.

Mass conservation tells us

$$\underbrace{\frac{dm_{cv}}{dt}}_{=0} = \dot{m}_1 - \dot{m}_2, \quad (7.32)$$

$$\dot{m}_1 = \dot{m}_2 = \dot{m}. \quad (7.33)$$

Energy conservation tells us

$$\underbrace{\frac{dE_{cv}}{dt}}_{=0} = \dot{Q}_{cv} - \dot{W}_{cv} + \dot{m} \left(h_1 + \frac{v_1^2}{2} \right) - \dot{m} \left(h_2 + \frac{v_2^2}{2} \right), \quad (7.34)$$

$$\frac{\dot{Q}_{cv}}{\dot{m}} = \frac{\dot{W}_{cv}}{\dot{m}} + (h_2 - h_1) + \frac{1}{2} (v_2^2 - v_1^2), \quad (7.35)$$

$$q_{cv} = w_{cv} + (h_2 - h_1) + \frac{1}{2} (v_2^2 - v_1^2). \quad (7.36)$$

We find from the tables that $P_2 = 101.3$ kPa, $h_2 = 2676.05$ kJ/kg, and $h_1 = 3230.82$ kJ/kg. So

$$\begin{aligned} q_{cv} &= \left(540 \frac{\text{kJ}}{\text{kg}} \right) + \left(\left(2676.05 \frac{\text{kJ}}{\text{kg}} \right) - \left(3230.82 \frac{\text{kJ}}{\text{kg}} \right) \right) \\ &\quad + \frac{1}{2} \left(\left(100 \frac{\text{m}}{\text{s}} \right)^2 - \left(160 \frac{\text{m}}{\text{s}} \right)^2 \right) \frac{\frac{\text{kJ}}{\text{kg}}}{1000 \frac{\text{m}^2}{\text{s}^2}}, \end{aligned} \quad (7.37)$$

$$= -22.6 \frac{\text{kJ}}{\text{kg}}. \quad (7.38)$$

This represents a loss of heat to the surroundings.

The second law, Eq. (7.9), tells us

$$s_2 - s_1 = \sum \frac{q_{cv,j}}{T_j} + \frac{\dot{\sigma}_{cv}}{\dot{m}}, \quad (7.39)$$

$$\frac{\dot{\sigma}_{cv}}{\dot{m}} = s_2 - s_1 - \frac{q_{cv}}{T}. \quad (7.40)$$

From the tables, we find $s_1 = 6.9212$ kJ/kg/K, $s_2 = 7.3549$ kJ/kg/K. So

$$\frac{\dot{\sigma}_{cv}}{\dot{m}} = \left(\left(7.3549 \frac{\text{kJ}}{\text{kg K}} \right) - \left(6.9212 \frac{\text{kJ}}{\text{kg K}} \right) \right) - \left(\frac{-22.6 \frac{\text{kJ}}{\text{kg}}}{500 \text{ K}} \right), \quad (7.41)$$

$$= 0.4789 \frac{\text{kJ}}{\text{kg K}} > 0. \quad (7.42)$$

The process is sketched in Fig. 7.2.

Example 7.3

Steam is flowing in a diffuser. At the entrance it has $P_1 = 0.2$ MPa, $T_1 = 200$ °C, $v_1 = 700$ m/s. At the exhaust it has $v_2 = 70$ m/s. Assume an adiabatic reversible process. Find the final pressure and temperature. See Fig. 7.3.

Because the process is reversible and adiabatic, the second law simply reduces to

$$s_2 = s_1. \quad (7.43)$$

We go to the tables and find $s_1 = 7.5066$ kJ/kg/K. So $s_2 = 7.5066$ kJ/kg/K.

Figure 7.2: $T - s$ and $P - v$ diagrams for steam turbine problem.

Figure 7.3: Steam diffuser schematic.

Now, the first law tells us

$$\underbrace{\frac{dE_{cv}}{dt}}_{=0} = \underbrace{\dot{Q}_{cv}}_{=0} - \underbrace{\dot{W}_{cv}}_{=0} + \dot{m} \left(h_1 + \frac{1}{2}v_1^2 + gz_1 \right) - \dot{m} \left(h_2 + \frac{1}{2}v_2^2 + gz_2 \right). \quad (7.44)$$

Now, we cannot neglect kinetic energy changes in a diffuser. We can neglect potential energy changes. We can also neglect unsteady effects as well as control volume work. We were told it is adiabatic, so heat transfer can be neglected. Thus, we get

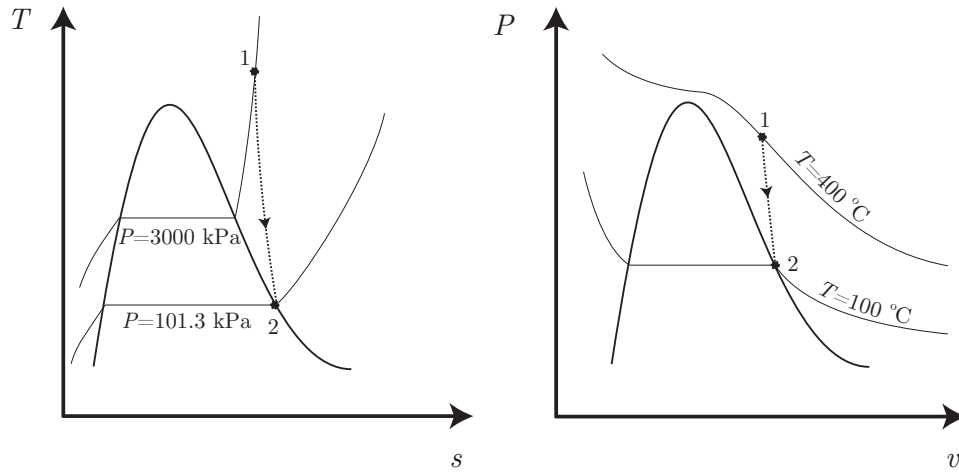
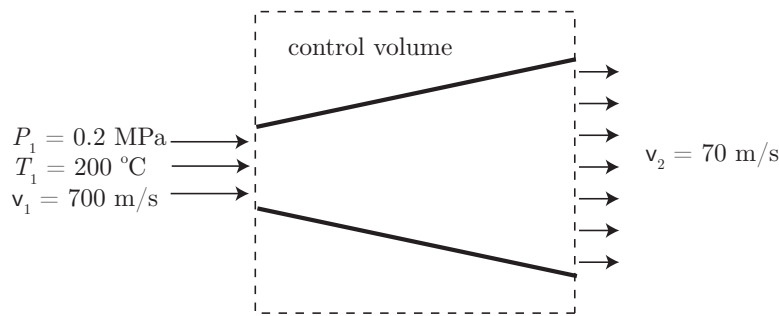
$$0 = \dot{m} \left(h_1 + \frac{1}{2}v_1^2 \right) - \dot{m} \left(h_2 + \frac{1}{2}v_2^2 \right), \quad (7.45)$$

$$h_2 = h_1 + \frac{1}{2}(v_1^2 - v_2^2). \quad (7.46)$$

The tables give us $h_1 = 2870.5$ kJ/kg. We thus can get

$$h_2 = \left(2870.5 \frac{\text{kJ}}{\text{kg}} \right) + \frac{1}{2} \left(\left(700 \frac{\text{m}}{\text{s}} \right)^2 - \left(70 \frac{\text{m}}{\text{s}} \right)^2 \right) \frac{\frac{\text{kJ}}{\text{kg}}}{1000 \frac{\text{m}^2}{\text{s}^2}} = 3113.05 \frac{\text{kJ}}{\text{kg}}. \quad (7.47)$$

Now, we know two properties, h_2 and s_2 . To find the final state, we have to double interpolate the

superheated steam tables. Doing so, we find

$$T_2 = 324.1 \text{ }^\circ\text{C}, \quad P_2 = 542 \text{ kPa.} \quad (7.48)$$

See Fig. 7.4 for a diagram of the process. Note the temperature rises in this process. The kinetic

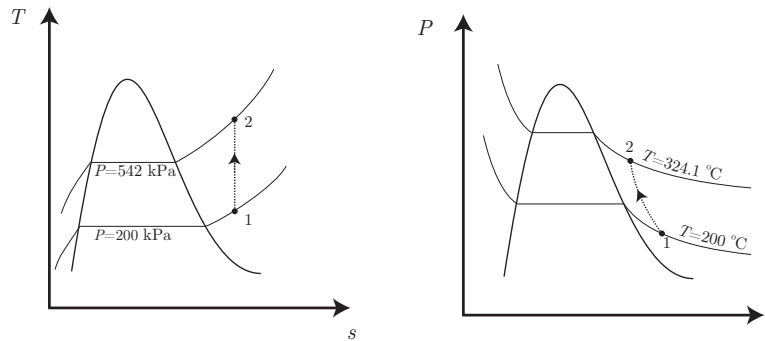

Figure 7.4: Steam diffuser schematic.

energy is being converted to thermal energy.

7.2 Bernoulli principle

Let us consider our thermodynamics in appropriate limit to develop the well known

- **BERNOULLI PRINCIPLE:** a useful equation in thermal science, often used beyond its realm of validity, relating pressure, fluid velocity, density, and fluid height, valid only in the limit in which mechanical energy is conserved.

The principle was first elucidated, though not without considerable turmoil within his prolific family, by Daniel Bernoulli,¹ depicted in Fig. 7.5.

For the Bernoulli principle to be formally valid requires some restrictive assumptions. We shall make them here in the context of thermodynamics. The same assumptions allow one to equivalently obtain the principle from an analysis of the linear momentum equation developed in fluid mechanics courses. In such a fluids development, we would need to make several additional, but roughly equivalent, assumptions. This equivalence is obtained because we shall develop the equation in the limit that *mechanical energy is not dissipated*. For our analysis here, we will make the following assumptions:

- the flow is steady,

¹D. Bernoulli, 1738, *Hydrodynamica, sive de Viribus et Motibus Fluidorum Commentarii*, J. H. Deckeri, Strasbourg.



Figure 7.5: Daniel Bernoulli (1700-1782), Dutch-born mathematician and physicist; image from http://mathshistory.st-andrews.ac.uk/Biographies/Bernoulli_Daniel.html.

- all processes are fully reversible,
- there is one inlet and exit, and
- there is contact with one thermal reservoir in which thermal energy is transferred reversibly.

Though we will not study it, there is another important version of the Bernoulli principle for unsteady flows.

Our second law, Eq. (7.6), reduces in the limits we study to

$$\underbrace{\frac{dS_{cv}}{dt}}_{=0} = \frac{\dot{Q}_{cv}}{T} + \dot{m}s_1 - \dot{m}s_2 + \underbrace{\dot{\sigma}_{cv}}_{=0}, \quad (7.49)$$

$$0 = \frac{\dot{Q}_{cv}}{T} + \dot{m}(s_1 - s_2), \quad (7.50)$$

$$\dot{m}(s_2 - s_1) = \frac{\dot{Q}_{cv}}{T}, \quad (7.51)$$

$$\dot{m}T(s_2 - s_1) = \dot{Q}_{cv}. \quad (7.52)$$

Now, let us non-rigorously generalize this somewhat and allow for differential heat transfer at a variety of temperatures so as to get

$$\dot{m} \int_1^2 T ds = \dot{Q}_{cv}. \quad (7.53)$$

In a more formal analysis from continuum mechanics, this step is much cleaner, but would require significant development. What we really wanted was a simplification for \dot{Q}_{cv} that we

could use in the relevant energy equation, Eq. (4.182), considered next:

$$\underbrace{\frac{dE_{cv}}{dt}}_{=0} = \underbrace{\dot{Q}_{cv}}_{=\dot{m} \int_1^2 T ds} - \dot{W}_{cv} + \dot{m} \left(h_1 + \frac{1}{2} \mathbf{v}_1^2 + gz_1 \right) - \dot{m} \left(h_2 + \frac{1}{2} \mathbf{v}_2^2 + gz_2 \right), \quad (7.54)$$

$$\underbrace{\frac{\dot{W}_{cv}}{\dot{m}}}_{w_{cv}} = \int_1^2 T ds + (h_1 - h_2) + \frac{1}{2}(\mathbf{v}_1^2 - \mathbf{v}_2^2) + g(z_1 - z_2). \quad (7.55)$$

Now, one form of the Gibbs equation, Eq. (6.65), has $T ds = dh - v dP$, so

$$\int_1^2 T ds = \int_1^2 dh - \int_1^2 v dP, \quad (7.56)$$

$$= h_2 - h_1 - \int_1^2 v dP, \quad (7.57)$$

$$\int_1^2 T ds + (h_1 - h_2) = - \int_1^2 v dP. \quad (7.58)$$

Now, substitute Eq. (7.58) into Eq. (7.55) to get

$$w_{cv} = \underbrace{\int_1^2 T ds + (h_1 - h_2)}_{=- \int_1^2 v dP} + \frac{1}{2}(\mathbf{v}_1^2 - \mathbf{v}_2^2) + g(z_1 - z_2), \quad (7.59)$$

$$= - \int_1^2 v dP + \frac{1}{2}(\mathbf{v}_1^2 - \mathbf{v}_2^2) + g(z_1 - z_2). \quad (7.60)$$

Now, if $w_{cv} = 0$, we get a rarely used, but valuable generalization of the Bernoulli principle:

$$0 = \int_1^2 v dP + \frac{1}{2}(\mathbf{v}_2^2 - \mathbf{v}_1^2) + g(z_2 - z_1). \quad (7.61)$$

7.2.1 Incompressible limit

In the important limit for liquids in which v is approximately constant, we recall that $\rho = 1/v$ and write Eq. (7.61) as

$$0 = v \int_1^2 dP + \frac{1}{2}(\mathbf{v}_2^2 - \mathbf{v}_1^2) + g(z_2 - z_1), \quad (7.62)$$

$$= v(P_2 - P_1) + \frac{1}{2}(\mathbf{v}_2^2 - \mathbf{v}_1^2) + g(z_2 - z_1), \quad (7.63)$$

$$= \frac{P_2 - P_1}{\rho} + \frac{1}{2}(\mathbf{v}_2^2 - \mathbf{v}_1^2) + g(z_2 - z_1). \quad (7.64)$$

We can rewrite this as

$$\boxed{\frac{P}{\rho} + \frac{1}{2}v^2 + gz = \text{constant},} \quad (7.65)$$

Bernoulli principle for an incompressible liquid.

In a different limit, that in which changes in kinetic and potential energy can be neglected, Eq. (7.60) reduces to

$$w_{cv} = - \int_1^2 v \, dP. \quad (7.66)$$

This integral is not the area under the curve in $P - v$ space. It is the area under the curve in $v - P$ space instead. Contrast this with the system result where we get ${}_1w_2 = \int_1^2 P \, dv$. In the important operation of pumping liquids, v is nearly constant, and we can say

$$w_{pump} = -v(P_2 - P_1), \quad (7.67)$$

$$\dot{W}_{pump} = \dot{m}v(P_1 - P_2). \quad (7.68)$$

7.2.2 Calorically perfect ideal gas limit

Let us consider the Bernoulli principle for a CPIG undergoing a reversible adiabatic process. For such a process, we have from Eq. (6.170) that $Pv^k = C$. Thus, $v = (C/P)^{1/k}$. Let us consider Eq. (7.61) for this case:

$$0 = \int_1^2 \left(\frac{C}{P}\right)^{\frac{1}{k}} dP + \frac{1}{2}(v_2^2 - v_1^2) + g(z_2 - z_1), \quad (7.69)$$

$$= \frac{k}{k-1} \left[P \left(\frac{C}{P}\right)^{\frac{1}{k}} \right]_{P_1}^{P_2} + \frac{1}{2}(v_2^2 - v_1^2) + g(z_2 - z_1), \quad (7.70)$$

$$= \frac{k}{k-1}(P_2v_2 - P_1v_1) + \frac{1}{2}(v_2^2 - v_1^2) + g(z_2 - z_1). \quad (7.71)$$

Thus, for a CPIG obeying the Bernoulli principle, we can say, taking $v = 1/\rho$,

$$\boxed{\frac{k}{k-1} \frac{P}{\rho} + \frac{1}{2}v^2 + gz = \text{constant},} \quad (7.72)$$

Bernoulli principle for a CPIG.

While this is fine and very similar to the form given for incompressible flow, it really should be simplified more because P is directly related to ρ for this compressible flow. Using, Eq. (6.170), $Pv^k = C = P_o v_o^k$ and $\rho_o = 1/v_o$, we can rewrite Eq. (7.72) as

$$\boxed{\frac{k}{k-1} \left(\frac{P}{P_o}\right)^{\frac{k-1}{k}} \frac{P_o}{\rho_o} + \frac{1}{2}v^2 + gz = \text{constant}.} \quad (7.73)$$

Similarly for isentropic pumps or turbines using CPIGs with negligible changes in kinetic and potential energies, Eq. (7.60) reduces to

$$w_{cv} = - \int_1^2 v \, dP, \quad (7.74)$$

$$= - \frac{k}{k-1} (P_2 v_2 - P_1 v_1), \quad (7.75)$$

$$= - \frac{k}{k-1} R (T_2 - T_1), \quad (7.76)$$

$$= - \frac{kRT_1}{k-1} \left(\frac{T_2}{T_1} - 1 \right), \quad (7.77)$$

$$= -c_P T_1 \left(\left(\frac{P_2}{P_1} \right)^{\frac{k-1}{k}} - 1 \right). \quad (7.78)$$

An isothermal pump or compressor using a CPIG has

$$w_{cv} = - \int_1^2 v \, dP, \quad (7.79)$$

$$= - \int_1^2 \frac{RT}{P} \, dP, \quad (7.80)$$

$$= -RT_1 \ln \frac{P_2}{P_1}, \quad (7.81)$$

$$= -P_1 v_1 \ln \frac{P_2}{P_1}. \quad (7.82)$$

7.2.3 Torricelli's formula

Let us consider a special case of the Bernoulli principle, known as Torricelli's formula, developed by Evangelista Torricelli,² the inventor of the barometer, and for whom the pressure unit torr is named (1 torr = 133.322 Pa = 1/760 atm.) Torricelli is sketched in Fig. 7.6.

Consider the scenario of Fig. 7.7. Here, a fluid is in an open container. The container has a small hole near its bottom. The fluid at the top of the container, $z = z_1$, is at $P_1 = P_{atm}$. The leaking fluid exhausts at the same pressure $P_2 = P_{atm}$. The fluid leaks at velocity \mathbf{v}_2 at a hole located at $z = z_2$. The fluid at the top of the container barely moves; so, it has negligible velocity, $\mathbf{v}_1 \sim 0$. The fluid exists in a constant gravitational field with gravitational acceleration g , as sketched. Assume the fluid is incompressible and all of the restrictions of the Bernoulli principle are present. Let us apply Eq. (7.65):

$$\frac{P_1}{\rho} + \frac{1}{2} \underbrace{v_1^2}_{\sim 0} + gz_1 = \frac{P_2}{\rho} + \frac{1}{2} v_2^2 + gz_2. \quad (7.83)$$

²E. Torricelli, 1643, *De Motu Gravium Naturaliter Accelerato*, Firenze.



Figure 7.6: Evangelista Torricelli (1608-1647), Italian physicist and mathematician; image from https://en.wikipedia.org/wiki/Evangelista_Torricelli.

Setting $P_1 = P_2 = P_{atm}$ and ignoring v_1 gives

$$gz_1 = \frac{1}{2}v_2^2 + gz_2, \quad (7.84)$$

$$\boxed{v_2 = \sqrt{2g(z_1 - z_2)}}, \quad (7.85)$$

Torricelli's formula.

Notice rearranging Torricelli's formula gives

$$\underbrace{\frac{1}{2}v_2^2}_{\text{kinetic energy}} = \underbrace{g(z_1 - z_2)}_{\text{potential energy}}. \quad (7.86)$$

It represents a balance of kinetic and potential energy of the fluid, and thus is concerned only with mechanical energy.

Example 7.4

Let us design a liquid water fountain by cutting a hole in a high pressure water pipe. See Fig. 7.8. We desire the final height of the water jet to be 30 m. The jet rises against a gravitational field with $g = 9.81 \text{ m/s}^2$. The atmospheric pressure is 100 kPa. Water has density $\rho = 997 \text{ kg/m}^3$. Find the necessary pipe gauge pressure P_1 and jet exit velocity v_2 .

Let us apply the Bernoulli principle between states 1 and 3, the pipe interior and the peak of the height of the fountain. We will estimate the velocity of the water in the pipe to be small, $v_1 \sim 0 \text{ m/s}$. We will also estimate the velocity at the apex of the motion to be negligible, $v_3 = 0 \text{ m/s}$.

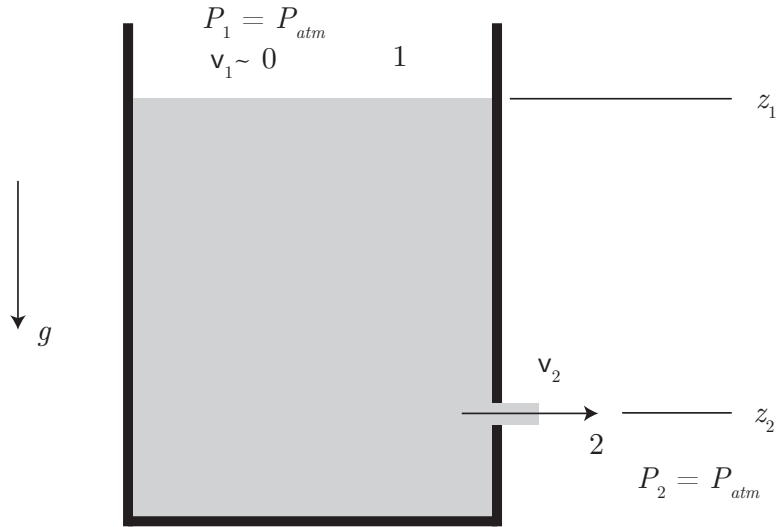

Figure 7.7: Fluid container with hole.

Let us apply Eq. (7.65):

$$\frac{P_1}{\rho} + \frac{1}{2} \underbrace{v_1^2}_{\sim 0} + gz_1 = \frac{P_2}{\rho} + \frac{1}{2} \underbrace{v_2^2}_{=0} + gz_2, \quad (7.87)$$

$$P_1 = P_{atm} + \rho g(z_2 - z_1), \quad (7.88)$$

$$\underbrace{P_1 - P_{atm}}_{=P_{gauge}} = \rho g(z_2 - z_1). \quad (7.89)$$

Substituting numbers, we find

$$P_{gauge} = \left(997 \frac{\text{kg}}{\text{m}^3}\right) \left(9.81 \frac{\text{m}}{\text{s}^2}\right) (30 \text{ m}) = 2.934 \times 10^5 \text{ Pa} = \boxed{293.4 \text{ kPa}}. \quad (7.90)$$

We can use the same principle to estimate the exit velocity, v_2 . Here, we take $z_1 \sim z_2$.

$$\frac{P_1}{\rho} + \frac{1}{2} \underbrace{v_1^2}_{\sim 0} + gz_1 = \frac{P_2}{\rho} + \frac{1}{2} v_2^2 + g \underbrace{z_2}_{\sim z_1}, \quad (7.91)$$

$$\frac{P_1}{\rho} = \frac{P_{atm}}{\rho} + \frac{1}{2} v_2^2, \quad (7.92)$$

$$v_2 = \sqrt{\frac{2(P_1 - P_{atm})}{\rho}}, \quad (7.93)$$

$$v_2 = \sqrt{\frac{2P_{gauge}}{\rho}}. \quad (7.94)$$

Substituting numbers, we find

$$v_2 = \sqrt{\frac{2(2.934 \times 10^5 \text{ Pa})}{997 \frac{\text{kg}}{\text{m}^3}}} = \boxed{24.26 \frac{\text{m}}{\text{s}}}. \quad (7.95)$$

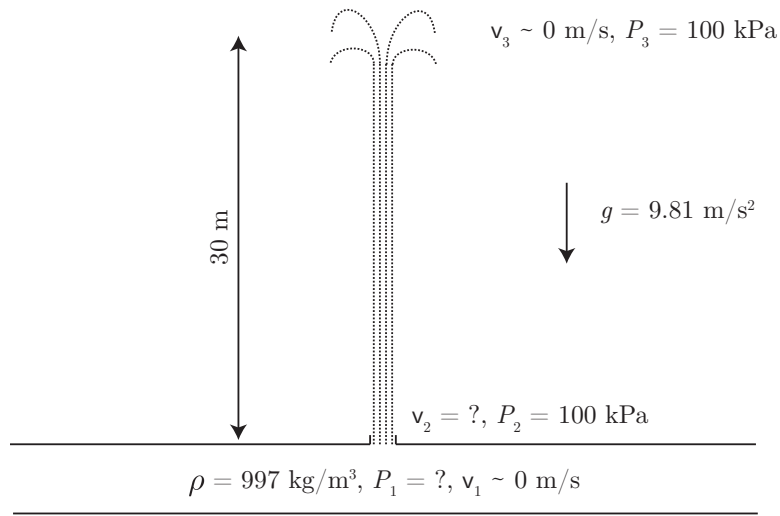

Figure 7.8: Sketch of simple water fountain.

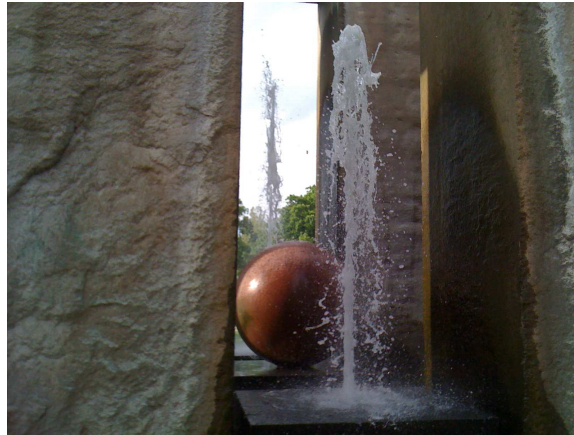

Figure 7.9: The University of Notre Dame's War Memorial Fountain, 4 June 2010.

One could use a similar analysis to estimate the necessary pressure to generate the jet of the University of Notre Dame's War Memorial Fountain, depicted in Fig. 7.9.

Example 7.5

Perform a similar calculation for the problem sketched in Fig. 7.8, but account for mass conservation. Take the cross-sectional area of the pipe to be $A_1 = A_4 = 1 \text{ m}^2$, and that of the hole to be $A_2 = 0.01 \text{ m}^2$. We measure $v_1 = 1 \text{ m/s}$. See Fig. 7.10. Assume we have the same $P_{gauge} = 293.4 \text{ kPa}$ as calculated earlier. Find the new height of the fountain, z_3 , and the new exit velocity v_2 .

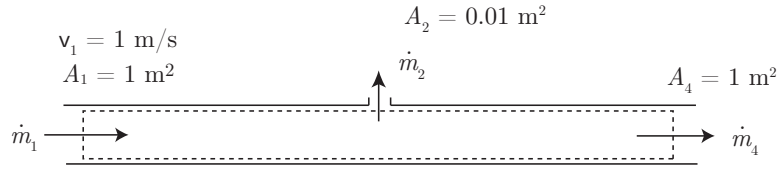

Figure 7.10: Schematic of mass balance for water fountain problem.

The mass balance gives us

$$\underbrace{\frac{dm_{cv}}{dt}}_{=0} = \dot{m}_1 - \dot{m}_2 - \dot{m}_4, \quad (7.96)$$

$$0 = \dot{m}_1 - \dot{m}_2 - \dot{m}_4, \quad (7.97)$$

$$\dot{m}_4 = \dot{m}_1 - \dot{m}_2. \quad (7.98)$$

We recall that $\dot{m} = \rho v A$, so

$$\rho v_4 A_4 = \rho v_1 A_1 - \rho v_2 A_2. \quad (7.99)$$

We assume incompressible flow, so $\rho_1 = \rho_2 = \rho_4 = \rho$, and we have $A_1 = A_4$, so

$$\rho v_4 A_1 = \rho v_1 A_1 - \rho v_2 A_2, \quad (7.100)$$

$$v_4 = v_1 - v_2 \frac{A_2}{A_1}. \quad (7.101)$$

This is nice, but not that useful. It simply predicts a lessening of velocity downstream of the hole.

The Bernoulli principle, Eq. (7.65), applied between 1 and 2 gives

$$\frac{P_1}{\rho} + \frac{1}{2}v_1^2 + gz_1 = \frac{P_2}{\rho} + \frac{1}{2}v_2^2 + g \underbrace{z_2}_{\sim z_1}, \quad (7.102)$$

$$\frac{P_1}{\rho} + \frac{1}{2}v_1^2 = \frac{P_{atm}}{\rho} + \frac{1}{2}v_2^2, \quad (7.103)$$

$$v_2 = \sqrt{\frac{2(P_1 - P_{atm})}{\rho} + v_1^2}, \quad (7.104)$$

$$= \sqrt{\frac{2P_{gauge}}{\rho} + v_1^2}. \quad (7.105)$$

With numbers, we get

$$v_2 = \sqrt{\frac{2(2.934 \times 10^5 \text{ Pa})}{997 \frac{\text{kg}}{\text{m}^3}} + \left(1 \frac{\text{m}}{\text{s}}\right)^2} = \boxed{24.28 \frac{\text{m}}{\text{s}}}. \quad (7.106)$$

The exit velocity is barely changed from our earlier analysis.

Now, determine the new height. Let us again apply Eq. (7.65):

$$\frac{P_1}{\rho} + \frac{1}{2}v_1^2 + gz_1 = \frac{P_3}{\rho} + \frac{1}{2}\underbrace{v_3^2}_{=0} + gz_3, \quad (7.107)$$

$$\frac{P_1}{\rho} + \frac{1}{2}v_1^2 + gz_1 = \frac{P_{atm}}{\rho} + gz_3, \quad (7.108)$$

$$\frac{P_1 - P_{atm}}{\rho} + \frac{1}{2}v_1^2 = g(z_3 - z_1), \quad (7.109)$$

$$z_3 - z_1 = \frac{P_{gauge}}{\rho g} + \frac{1}{2g}v_1^2. \quad (7.110)$$

Substituting numbers, we get

$$z_3 - z_1 = \frac{2.934 \times 10^5 \text{ Pa}}{\left(997 \frac{\text{kg}}{\text{m}^3}\right) (9.81 \frac{\text{m}}{\text{s}})} + \frac{1}{2 \left(9.81 \frac{\text{m}}{\text{s}^2}\right)} \left(1 \frac{\text{m}}{\text{s}}\right)^2 = \boxed{30.05 \text{ m.}} \quad (7.111)$$

The extra boost in height comes from accounting for the initial kinetic energy of the water.

7.3 Component efficiency

Recall for cycles, as shown in the analysis surrounding Eq. (4.325), we defined a thermal efficiency as what you want/what you pay for, which for a power cycle is $\eta = W_{net}/Q_H$. We can further define efficiencies for components. For a component, we will take an efficiency for some devices to be

$$\eta_{component} = \frac{\text{what we get}}{\text{the best we could get}}. \quad (7.112)$$

For other devices, we will take an efficiency to be

$$\eta_{component} = \frac{\text{the least required}}{\text{what is actually required}}. \quad (7.113)$$

The optimal is generally an isentropic device. So, for example, for a turbine, we say

$$\eta_{turbine} = \frac{\text{actual work}}{\text{work done by an isentropic turbine}} = \frac{w}{w_s}. \quad (7.114)$$

Here, the subscript “s” denotes isentropic.

For a nozzle, we would like to maximize the kinetic energy of the working fluid, so we say

$$\eta_{nozzle} = \frac{v^2}{v_s^2}. \quad (7.115)$$

However for pumps and compressors, the isentropic pump requires the least work input. So we take instead

$$\eta_{\text{pump,compressor}} = \frac{w_s}{w}. \quad (7.116)$$

Example 7.6

N_2 is adiabatically compressed from $T_1 = 300 \text{ K}$, $P_1 = 100 \text{ kPa}$ to $P_2 = 1000 \text{ kPa}$. The compressor efficiency is $\eta_c = 0.9$. Find the final state and the compression work per unit mass. Assume N_2 is a CIIG.

The first law for adiabatic compression gives

$$w = h_2 - h_1. \quad (7.117)$$

Table A.8 from BS tells us that at $T_1 = 300 \text{ K}$, $h_1 = 311.67 \text{ kJ/kg}$, $s_{T_1}^o = 6.8463 \text{ kJ/kg/K}$. But we are not sure what state 2 is, and the first law does not help yet, as we do not know either w or h_2 .

Let us calculate state 2 assuming an isentropic process, and then use our knowledge of compressor efficiency to correct for real effects. We first note for N_2 that

$$R = \frac{\bar{R}}{M} = \frac{8.31451 \frac{\text{kJ}}{\text{kmole K}}}{28.013 \frac{\text{kg}}{\text{kmole}}} = 0.2968 \frac{\text{kJ}}{\text{kg K}}. \quad (7.118)$$

From Eq. (6.98), we can conclude that for an isentropic process in which $s_2 = s_1$ that

$$s_2 - s_1 = 0 = s_{T_2}^o - s_{T_1}^o - R \ln \frac{P_2}{P_1}, \quad (7.119)$$

$$s_{T_2}^o = s_{T_1}^o + R \ln \frac{P_2}{P_1}, \quad (7.120)$$

$$= \left(6.8463 \frac{\text{kJ}}{\text{kg K}} \right) + \left(0.2968 \frac{\text{kJ}}{\text{kg K}} \right) \ln \frac{1000 \text{ kPa}}{100 \text{ kPa}}, \quad (7.121)$$

$$= 7.52971 \frac{\text{kJ}}{\text{kg K}}. \quad (7.122)$$

Knowing $s_{T_2}^o$, we next interpolate Table A.8 from BS to get

$$T_{2s} = 576.133 \text{ K}, \quad h_{2s} = 601.712 \frac{\text{kJ}}{\text{kg}}. \quad (7.123)$$

(Note the CPIG assumption would have yielded $T_{2s} = (300 \text{ K})(10)^{0.286} = 579.209 \text{ K}$). So the work for the isentropic compressor is

$$w_s = h_{2s} - h_1 = \left(601.712 \frac{\text{kJ}}{\text{kg}} \right) - \left(311.67 \frac{\text{kJ}}{\text{kg}} \right) = 290.042 \frac{\text{kJ}}{\text{kg}}. \quad (7.124)$$

Now, consider the compressor efficiency:

$$\eta_c = \frac{w_s}{w}, \quad (7.125)$$

$$w = \frac{w_s}{\eta_c}, \quad (7.126)$$

$$= \frac{290.042 \frac{\text{kJ}}{\text{kg}}}{0.9}, \quad (7.127)$$

$$= \boxed{322.269 \frac{\text{kJ}}{\text{kg}}}. \quad (7.128)$$

Thus, we have the actual work per unit mass. So the actual enthalpy at state 2 can be derived from the first law:

$$h_2 = h_1 + w = \left(311.67 \frac{\text{kJ}}{\text{kg}} \right) + \left(322.269 \frac{\text{kJ}}{\text{kg}} \right) = 633.939 \frac{\text{kJ}}{\text{kg}}. \quad (7.129)$$

Now, knowing h_2 , we can again interpolate Table A.8 of BS to find the final temperature T_2 to be

$$T_2 = \boxed{606.263 \text{ K}}. \quad (7.130)$$

We had to add more energy to achieve the non-isentropic compression relative to the isentropic compression.

_____ |

Chapter 8

Cycles

Read BS, Chapters 9, 10

In this chapter, we will delve more deeply into some thermodynamic cycles.

8.1 Rankine

Large electric power plants typically utilize a vapor power cycle. Regardless of the heat source, be it nuclear or combustion of coal, oil, natural gas, wood chips, etc., the remaining details of these plants are similar. Typically a pure working fluid, usually water, is circulated through a cycle, and that fluid trades heat and work with its surroundings. We sketch a typical power plant cycle for electricity generation in Fig. 8.1. The ideal Rankine cycle was first described in 1859 by William John Macquorn Rankine, long after the steam engine was in wide usage. Expanding on our earlier discussion of Ch. 4.5, the cycle has the following steps:

- 1 \rightarrow 2: isentropic compression in a pump,
- 2 \rightarrow 3: isobaric heating in a boiler,
- 3 \rightarrow 4: isentropic expansion in a turbine, and
- 4 \rightarrow 1: isobaric cooling in a condenser.

Two variants of the $T - s$ diagram are given in Fig. 8.2. The first is more efficient as it has the appearance of a Carnot cycle. However, it is impractical, as it induces liquid water in the turbine, that can damage its blades. So the second is more common.

The thermal efficiency, consistent with what was first introduced in Eq. (4.326), is

$$\eta = \frac{\dot{W}_{net}}{\dot{Q}_H} = \frac{\dot{W}_{turbine} + \dot{W}_{pump}}{\dot{Q}_{boiler}}. \quad (8.1)$$

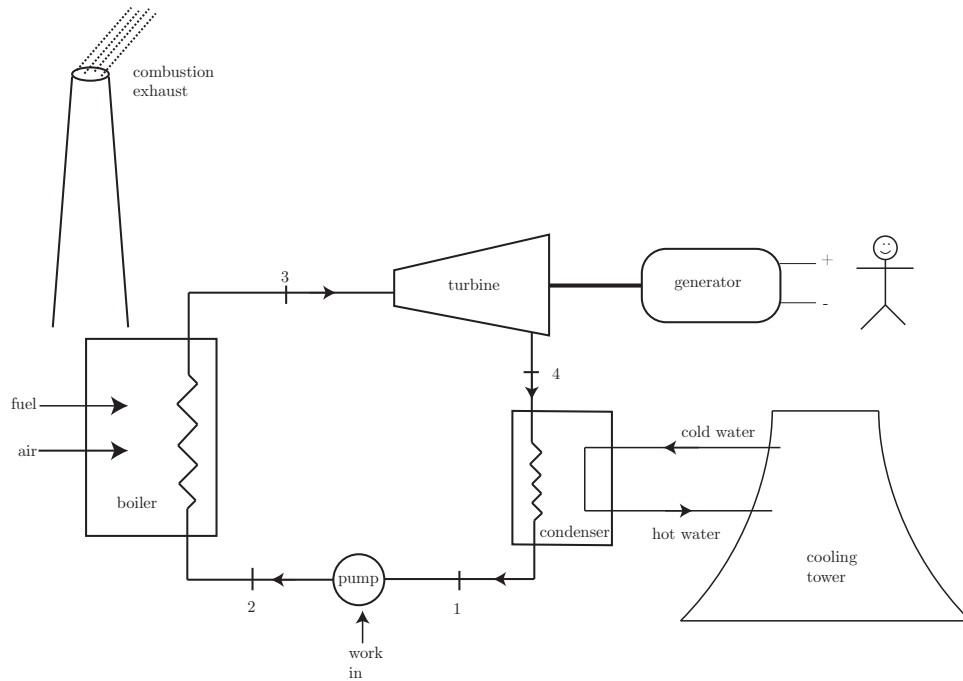

Figure 8.1: Rankine cycle schematic.

This reduces to

$$\eta = \frac{\dot{m}((h_3 - h_4) + (h_1 - h_2))}{\dot{m}(h_3 - h_2)}, \quad (8.2)$$

$$= 1 - \frac{h_4 - h_1}{h_3 - h_2}, \quad (8.3)$$

$$= 1 - \frac{q_{out,condenser}}{q_{in,boiler}}. \quad (8.4)$$

This is consistent with the earlier Eq. (5.8). Note that because the Rankine cycle is *not* a Carnot cycle, we have $q_{out,condenser}/q_{in,boiler} \neq T_1/T_3$.

Power plants are sometimes characterized by their

- BACK WORK RATIO: bwr , the ratio of pump work to turbine work.

Here,

$$bwr = \frac{|\text{pump work}|}{|\text{turbine work}|} = \frac{h_2 - h_1}{h_3 - h_4}. \quad (8.5)$$

We model the pump work as an isentropic process. Recall our analysis for isentropic pumps that generated Eq. (7.67). The Gibbs equation, Eq. (6.66), gives $dh = T ds + v dP$. If $ds = 0$, we have

$$dh = v dP, \quad (8.6)$$

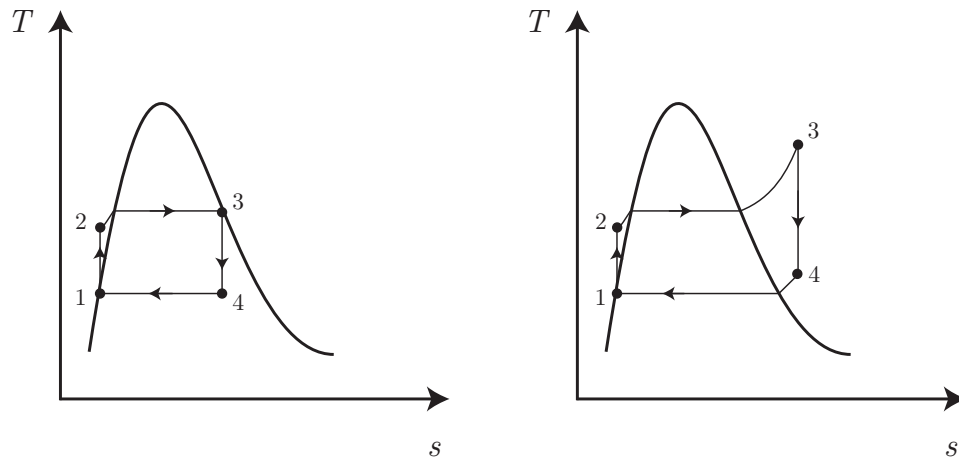
Figure 8.2: $T - s$ for two Rankine cycles.

Thus, for the pump

$$h_2 - h_1 = v(P_2 - P_1), \quad (8.7)$$

because v is nearly constant, so the integration is simple.

It might be tempting to make the Rankine cycle into a Carnot cycle as sketched in Fig. 8.3. However, it is practically difficult to build a pump to handle two-phase mixtures.

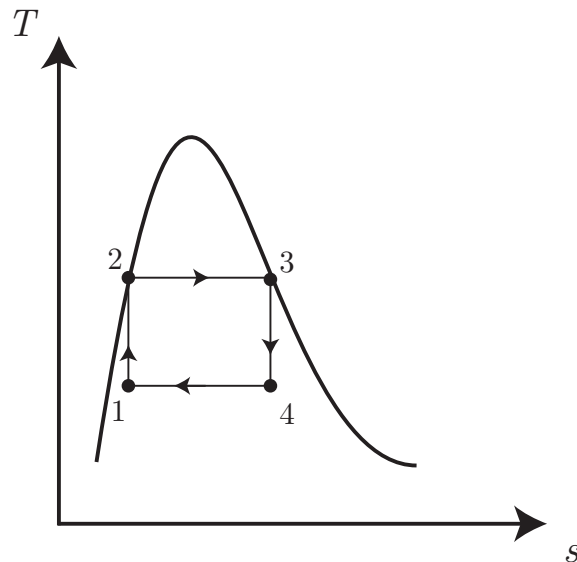

Figure 8.3: Rankine-Carnot cycle.

The gas phase can seriously damage the pump. Some features that could be desirable for a Rankine cycle include

- high power output: One can enhance this by raising the fluid to a high temperature during the combustion process or by pumping the fluid to a high pressure. Both strategies soon run into material limits; turbine blades melt and pipes burst. Another strategy is to lower the condenser pressure. That means that one must maintain a vacuum, and this can be difficult.
- high thermal efficiency: The key design strategy here lies in 1) increasing component efficiencies, and 2) rendering the overall cycle as much like a Carnot cycle as is feasible. Modern power plants have had revolutionary increases in overall thermal efficiency because of enhancements that make the process more Carnot-like.

There are some important loss mechanisms in the Rankine cycle that inhibit efficiency. They include

- Turbine losses: These are the major losses. To avoid these losses requires detailed consideration of fluid mechanics, material science, and heat transfer and is beyond the scope of classical thermodynamics. Thermodynamics develops broad measures of turbine efficiency such as $\eta_{turbine} = (h_3 - h_4)/(h_3 - h_{4s})$.
- Pump losses: Again, fluid mechanics, machine design, and material science are required to analyze how to actually avoid these losses. Thermodynamics characterizes them by pump efficiency, $\eta_{pump} = (h_{2s} - h_1)/(h_2 - h_1)$.
- Heat transfer losses from components.
- Pressure drop in pipes.
- Incomplete fuel combustion.
- Pollution removal devices.
- Loss of heat to surroundings in the condenser.

One simple design strategy to make the system more Carnot-like is to use

- REHEAT: a design strategy in which steam is extracted from the turbine before it is fully expanded, then sent to the boiler again, and re-expanded through the remainder of the turbine.

This has the effect of making the system more like a Carnot cycle. A schematic and $T - s$ diagram for the Rankine cycle with reheat is given in Fig. 8.4.

Example 8.1

Consider water in a Rankine power cycle with reheat. The first turbine has water enter at $P_3 = 8000$ kPa, $T_3 = 500$ °C. The water expands to 600 kPa, undergoes reheat, and then expands again to 10 kPa. The mass flow rate is $\dot{m} = 2.63 \times 10^5$ kg/hr. We have $\eta_t = 0.88$ for each turbine, and $\eta_p = 0.80$ for the pump. Find the net power generated, η , and the heat transfer to the condenser.

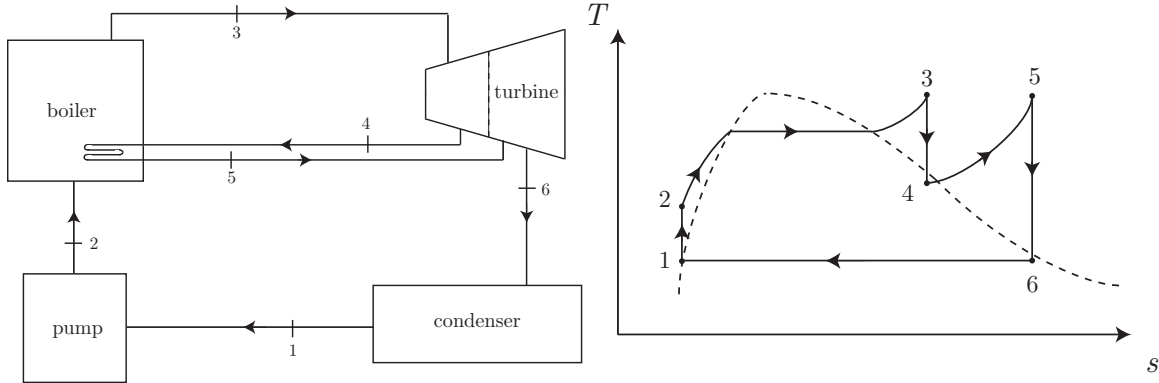
Figure 8.4: Rankine cycle with reheat schematic and $T - s$ diagram.

Let us consider the big picture first. The net specific power will be the positive effect of the two turbines and the negative effect of the pump:

$$w_{net} = \underbrace{(h_3 - h_4)}_{\text{turbine 1}} + \underbrace{(h_5 - h_6)}_{\text{turbine 2}} + \underbrace{(h_1 - h_2)}_{\text{pump}}. \quad (8.8)$$

Now, the heat input for the reheat is in two stages:

$$q_{in} = (h_3 - h_2) + (h_5 - h_4). \quad (8.9)$$

Lastly, the heat rejection in the condenser is

$$q_{out} = h_6 - h_1. \quad (8.10)$$

Let us start at the entrance of the first turbine, at 3. We are given P_3 and T_3 , so we consult the tables and find

$$h_3 = 3398.27 \frac{\text{kJ}}{\text{kg}}, \quad s_3 = 6.7239 \frac{\text{kJ}}{\text{kg K}}. \quad (8.11)$$

We are given $P_4 = 600 \text{ kPa}$. Now, let us get the ideal behavior of the turbine: $s_{4s} = s_3 = 6.7239 \text{ kJ/kg/K}$. At this condition, we find state 4 is a two-phase mixture. At 600 kPa, we find $s_f = 1.9311 \text{ kJ/kg/K}$, $s_g = 6.7600 \text{ kJ/kg/K}$. So

$$x_{4s} = \frac{s_{4s} - s_f}{s_g - s_f} = \frac{\left(6.7239 \frac{\text{kJ}}{\text{kg K}}\right) - \left(1.9311 \frac{\text{kJ}}{\text{kg K}}\right)}{\left(6.7600 \frac{\text{kJ}}{\text{kg K}}\right) - \left(1.9311 \frac{\text{kJ}}{\text{kg K}}\right)} = 0.992524. \quad (8.12)$$

We can thus get h_{4s} by consulting the tables to find

$$h_{4s} = h_f + x_{4s}h_{fg} = \left(670.54 \frac{\text{kJ}}{\text{kg}}\right) + (0.992524) \left(2086.26 \frac{\text{kJ}}{\text{kg}}\right) = 2741.2 \frac{\text{kJ}}{\text{kg}}. \quad (8.13)$$

Now, $\eta_t = (h_3 - h_4)/(h_3 - h_{4s})$, so

$$h_4 = h_3 - \eta_t(h_3 - h_{4s}), \quad (8.14)$$

$$= \left(3398.27 \frac{\text{kJ}}{\text{kg}}\right) - (0.88) \left(\left(3398.27 \frac{\text{kJ}}{\text{kg}}\right) - \left(2741.2 \frac{\text{kJ}}{\text{kg}}\right) \right), \quad (8.15)$$

$$= 2820.05 \frac{\text{kJ}}{\text{kg}}. \quad (8.16)$$

Now, state 5 is after the reheat, that was isobaric at $P_4 = P_5 = 600$ kPa, and the reheating returns the temperature to $T_5 = 500$ °C. From the superheat tables, we find $h_5 = 3482.75$ kJ/kg, $s_5 = 8.0020$ kJ/kg/K. After expansion in the second turbine, we have $s_{6s} = s_5 = 8.0020$ kJ/kg. And we were given $P_6 = 10$ kPa. We consult the saturation tables to find at this pressure $s_f = 0.6492$ kJ/kg/K, $s_g = 8.1501$ kJ/kg/K. Thus,

$$x_{6s} = \frac{s_{6s} - s_f}{s_g - s_f} = \frac{\left(8.0020 \frac{\text{kJ}}{\text{kg K}}\right) - \left(0.6492 \frac{\text{kJ}}{\text{kg K}}\right)}{\left(8.1501 \frac{\text{kJ}}{\text{kg K}}\right) - \left(0.6492 \frac{\text{kJ}}{\text{kg K}}\right)} = 0.980256. \quad (8.17)$$

The tables then give the necessary information to compute h_{6s} :

$$h_{6s} = h_f + x_{6s}h_{fg} = \left(191.81 \frac{\text{kJ}}{\text{kg}}\right) + (0.980256) \left(2392.82 \frac{\text{kJ}}{\text{kg}}\right) = 2537.39 \frac{\text{kJ}}{\text{kg}}. \quad (8.18)$$

Now, the actual h_6 is found via

$$h_6 = h_5 - \eta_t(h_5 - h_{6s}), \quad (8.19)$$

$$= \left(3482.75 \frac{\text{kJ}}{\text{kg}}\right) - (0.88) \left(\left(3482.75 \frac{\text{kJ}}{\text{kg}}\right) - \left(2537.39 \frac{\text{kJ}}{\text{kg}}\right)\right), \quad (8.20)$$

$$= 2650.83 \frac{\text{kJ}}{\text{kg}}. \quad (8.21)$$

Now, the tables give us

$$h_1 = h_f = 191.81 \frac{\text{kJ}}{\text{kg}}, \quad v_1 = v_f = 0.001010 \frac{\text{m}^3}{\text{kg}}. \quad (8.22)$$

For the pump, we have $P_1 = P_6 = 10$ kPa and $P_2 = P_3 = 8000$ kPa. So

$$\eta_p = \frac{w_s}{w_p}, \quad (8.23)$$

$$w_p = \frac{w_s}{\eta_p}, \quad (8.24)$$

$$= \frac{v_1(P_2 - P_1)}{\eta_p}, \quad (8.25)$$

$$= \frac{\left(0.001010 \frac{\text{m}^3}{\text{kg}}\right) \left((8000 \text{ kPa}) - (10 \text{ kPa})\right)}{0.8}, \quad (8.26)$$

$$= 10.0874 \frac{\text{kJ}}{\text{kg}}. \quad (8.27)$$

So

$$h_2 = h_1 + w_p, \quad (8.28)$$

$$= \left(191.81 \frac{\text{kJ}}{\text{kg}}\right) + \left(10.0874 \frac{\text{kJ}}{\text{kg}}\right), \quad (8.29)$$

$$= 201.897 \frac{\text{kJ}}{\text{kg}}. \quad (8.30)$$

Now, substitute all these values into Eq. (8.8) and get

$$\begin{aligned}
 w_{net} &= \underbrace{\left(\left(3398.27 \frac{\text{kJ}}{\text{kg}} \right) - \left(2820.05 \frac{\text{kJ}}{\text{kg}} \right) \right)}_{\text{turbine 1}} \\
 &\quad + \underbrace{\left(\left(3482.75 \frac{\text{kJ}}{\text{kg}} \right) - \left(2650.83 \frac{\text{kJ}}{\text{kg}} \right) \right)}_{\text{turbine 2}} \\
 &\quad + \underbrace{\left(\left(191.81 \frac{\text{kJ}}{\text{kg}} \right) - \left(201.897 \frac{\text{kJ}}{\text{kg}} \right) \right)}_{\text{pump}}, \tag{8.31}
 \end{aligned}$$

$$= 1400.05 \frac{\text{kJ}}{\text{kg}}. \tag{8.32}$$

On a mass basis, we have

$$\dot{W} = \dot{m}w_{net} = \left(2.63 \times 10^5 \frac{\text{kg}}{\text{hr}} \right) \left(\frac{\text{hr}}{3600 \text{ s}} \right) \left(1400.05 \frac{\text{kJ}}{\text{kg}} \right) = \boxed{1.02282 \times 10^5 \text{ kW}}. \tag{8.33}$$

From Eq. (8.9), the heat added is

$$\begin{aligned}
 q_{in} &= \underbrace{\left(\left(3398.27 \frac{\text{kJ}}{\text{kg}} \right) - \left(201.897 \frac{\text{kJ}}{\text{kg}} \right) \right)}_{\text{first boiling}} \\
 &\quad + \underbrace{\left(\left(3482.75 \frac{\text{kJ}}{\text{kg}} \right) - \left(2820.05 \frac{\text{kJ}}{\text{kg}} \right) \right)}_{\text{second boiling}}, \tag{8.34}
 \end{aligned}$$

$$= 3859.07 \frac{\text{kJ}}{\text{kg}}. \tag{8.35}$$

So the cycle's thermal efficiency is

$$\eta = \frac{w_{net}}{q_{in}} = \frac{1400.05 \frac{\text{kJ}}{\text{kg}}}{3859.07 \frac{\text{kJ}}{\text{kg}}} = \boxed{0.362795}. \tag{8.36}$$

The heat per unit mass rejected in the condenser is from Eq. (8.10):

$$q_{out} = \left(2650.83 \frac{\text{kJ}}{\text{kg}} \right) - \left(191.81 \frac{\text{kJ}}{\text{kg}} \right) = 2459.02 \frac{\text{kJ}}{\text{kg}}. \tag{8.37}$$

So the power rejected as heat is

$$\dot{Q}_L = \dot{m}q_{out} = \left(2.63 \times 10^5 \frac{\text{kg}}{\text{hr}} \right) \left(\frac{\text{hr}}{3600 \text{ s}} \right) \left(2459.02 \frac{\text{kJ}}{\text{kg}} \right) = \boxed{1.79645 \times 10^5 \text{ kW}}. \tag{8.38}$$

Example 8.2

Repeat the previous analysis without reheat. Find the thermal efficiency.

In this case state 4 would be taken down to 10 kPa. We would have

$$x_{4s} = \frac{s_{4s} - s_f}{s_g - s_f} = \frac{\left(6.7239 \frac{\text{kJ}}{\text{kg K}}\right) - \left(0.6492 \frac{\text{kJ}}{\text{kg K}}\right)}{\left(8.1501 \frac{\text{kJ}}{\text{kg K}}\right) - \left(0.6492 \frac{\text{kJ}}{\text{kg K}}\right)} = 0.809863. \quad (8.39)$$

We can thus get h_{4s} by consulting the tables to find

$$h_{4s} = h_f + x_{4s}h_{fg} = \left(191.81 \frac{\text{kJ}}{\text{kg}}\right) + (0.809863) \left(2392.82 \frac{\text{kJ}}{\text{kg}}\right) = 2129.67 \frac{\text{kJ}}{\text{kg}}. \quad (8.40)$$

Now

$$h_4 = h_3 - \eta_t(h_3 - h_{4s}), \quad (8.41)$$

$$= \left(3398.27 \frac{\text{kJ}}{\text{kg}}\right) - (0.88) \left(\left(3398.27 \frac{\text{kJ}}{\text{kg}}\right) - \left(2129.67 \frac{\text{kJ}}{\text{kg}}\right) \right), \quad (8.42)$$

$$= 2281.90 \frac{\text{kJ}}{\text{kg}}. \quad (8.43)$$

We then get

$$w_{net} = h_3 - h_4 - w_p = \left(3398.27 \frac{\text{kJ}}{\text{kg}}\right) - \left(2281.90 \frac{\text{kJ}}{\text{kg}}\right) - \left(10.0874 \frac{\text{kJ}}{\text{kg}}\right) = 1106.28 \frac{\text{kJ}}{\text{kg}}. \quad (8.44)$$

We also get

$$q_{in} = h_3 - h_2 = \left(3398.27 \frac{\text{kJ}}{\text{kg}}\right) - \left(201.897 \frac{\text{kJ}}{\text{kg}}\right) = 3196.37 \frac{\text{kJ}}{\text{kg}}. \quad (8.45)$$

So

$$\eta = \frac{w_{net}}{q_{in}} = \frac{1106.28 \frac{\text{kJ}}{\text{kg}}}{3196.37 \frac{\text{kJ}}{\text{kg}}} = \boxed{0.346106}. \quad (8.46)$$

The thermal efficiency without reheat (0.346106) is *less* than that with reheat (0.362795). The reheat altered the topology of the $T - s$ diagram to make it more Carnot-like, and thus generated a more efficient use of resources.

Example 8.3

A Rankine power cycle with water as the working fluid has $\eta_t = \eta_p = 0.88$. The turbine inlet pressure and temperature are at $P_3 = 1200$ psia, $T_3 = 1000$ °F. The condenser pressure is at $P_4 = 1$ psia. The steam generator provides $\dot{Q}_H = 2 \times 10^9$ Btu/hr. In the condenser the cooling water enters at 60 °F, and we wish to keep the exit cooling water temperature at 80 °F. Find the net power, the thermal efficiency, and the mass flow rate of cooling water, \dot{m}_{cw} .

We interpolate the steam tables to find

$$h_3 = 1499.6 \frac{\text{Btu}}{\text{lbm}}, \quad s_3 = 1.6297 \frac{\text{Btu}}{\text{lbm } ^\circ\text{R}}. \quad (8.47)$$

For an isentropic turbine, we have $s_{4s} = s_3 = 1.6297 \text{ Btu/lbm/}^\circ\text{R}$. At $P_4 = 1 \text{ psia}$, we find state $4s$ is a two-phase mixture:

$$x_{4s} = \frac{s_4 - s_f}{s_g - s_f} = \frac{\left(1.6297 \frac{\text{Btu}}{\text{lbm}^\circ\text{R}}\right) - \left(0.1327 \frac{\text{Btu}}{\text{lbm}^\circ\text{R}}\right)}{\left(1.9779 \frac{\text{Btu}}{\text{lbm}^\circ\text{R}}\right) - \left(0.1327 \frac{\text{Btu}}{\text{lbm}^\circ\text{R}}\right)} = 0.811. \quad (8.48)$$

Thus,

$$h_{4s} = h_f + x_{4s}h_{fg} = \left(69.74 \frac{\text{Btu}}{\text{lbm}}\right) + (0.811) \left(1036 \frac{\text{Btu}}{\text{lbm}}\right) = 909.9 \frac{\text{Btu}}{\text{lbm}}. \quad (8.49)$$

Now, for the actual turbine, we get

$$h_4 = h_3 - \eta_t(h_3 - h_{4s}), \quad (8.50)$$

$$= \left(1499.7 \frac{\text{Btu}}{\text{lbm}}\right) - (0.88) \left(\left(1499.7 \frac{\text{Btu}}{\text{lbm}}\right) - \left(909.9 \frac{\text{Btu}}{\text{lbm}}\right)\right), \quad (8.51)$$

$$= 979.9 \frac{\text{Btu}}{\text{lbm}}. \quad (8.52)$$

Now, after the condenser, we take $x_1 = 0$, so $h_1 = h_f$, $s_1 = s_f$, and $v_1 = v_f$, all at $P_1 = 1 \text{ psia}$. These yield

$$h_1 = 69.74 \frac{\text{Btu}}{\text{lbm}}, \quad s_1 = 0.1327 \frac{\text{Btu}}{\text{lbm}^\circ\text{R}}, \quad v_1 = 0.01614 \frac{\text{ft}^3}{\text{lbm}}. \quad (8.53)$$

Now,

$$w_p = \frac{w_s}{\eta_p}, \quad (8.54)$$

$$= \frac{v(P_4 - P_3)}{\eta_p}, \quad (8.55)$$

$$= \frac{\left(0.01614 \frac{\text{ft}^3}{\text{lbm}}\right) \left(\left(1200 \frac{\text{lb}_f}{\text{in}^2}\right) - \left(1 \frac{\text{lb}_f}{\text{in}^2}\right)\right) 144 \text{ in}^2}{0.88} \frac{\text{Btu}}{\text{ft}^2 778 \text{ ft lb}_f}, \quad (8.56)$$

$$= 4.07 \frac{\text{Btu}}{\text{lbm}}. \quad (8.57)$$

Now,

$$h_2 = h_1 + w_p = \left(69.74 \frac{\text{Btu}}{\text{lbm}}\right) + \left(4.07 \frac{\text{Btu}}{\text{lbm}}\right) = 73.81 \frac{\text{Btu}}{\text{lbm}}. \quad (8.58)$$

In the boiler, we have

$$\dot{Q}_H = \dot{m}(h_3 - h_2), \quad (8.59)$$

$$\dot{m} = \frac{\dot{Q}_H}{h_3 - h_2}, \quad (8.60)$$

$$= \frac{2 \times 10^9 \frac{\text{Btu}}{\text{hr}}}{\left(1499.7 \frac{\text{Btu}}{\text{lbm}}\right) - \left(73.81 \frac{\text{Btu}}{\text{lbm}}\right)} \frac{\text{hr}}{3600 \text{ s}}, \quad (8.61)$$

$$= 390 \frac{\text{lbm}}{\text{s}}. \quad (8.62)$$

We also note

$$\dot{Q}_H = \left(2 \times 10^9 \frac{\text{Btu}}{\text{hr}}\right) \frac{\text{hr}}{3600 \text{ s}} = 5.556 \times 10^5 \frac{\text{Btu}}{\text{s}}. \quad (8.63)$$

Now, the net power is the sum of the turbine and pump work:

$$\dot{W}_{net} = \dot{m}((h_3 - h_4) + (h_1 - h_2)), \quad (8.64)$$

$$= \left(390 \frac{\text{lbm}}{\text{s}}\right) \left(\left(1499.6 \frac{\text{Btu}}{\text{lbm}}\right) - \left(979.9 \frac{\text{Btu}}{\text{lbm}}\right) \right) + \left(\left(69.74 \frac{\text{Btu}}{\text{lbm}}\right) - \left(73.81 \frac{\text{Btu}}{\text{lbm}}\right) \right), \quad (8.65)$$

$$= \boxed{2.01 \times 10^5 \frac{\text{Btu}}{\text{s}}}. \quad (8.66)$$

The thermal efficiency is thus

$$\eta = \frac{\dot{W}_{net}}{\dot{Q}_H} = \frac{2.01 \times 10^5 \frac{\text{Btu}}{\text{s}}}{5.556 \times 10^5 \frac{\text{Btu}}{\text{s}}} = \boxed{0.3618}. \quad (8.67)$$

The cooling water and the water in the Rankine cycle exchange heat in the condenser. This is sketched in Fig. 8.5. The first law for the heat exchanger is

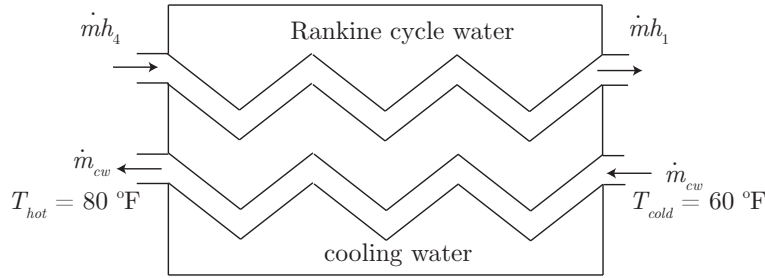

Figure 8.5: Rankine cycle condenser/heat exchanger.

$$\underbrace{\frac{dE_{cv}}{dt}}_{=0} = \underbrace{\dot{Q}_{cv}}_{=0} - \underbrace{\dot{W}_{cv}}_{=0} + \dot{m}(h_4 - h_1) + \dot{m}_{cw}c_P(T_{cold} - T_{hot}), \quad (8.68)$$

$$0 = \dot{m}(h_4 - h_1) + \dot{m}_{cw}c_P(T_{cold} - T_{hot}), \quad (8.69)$$

$$\dot{m}_{cw} = \frac{\dot{m}(h_4 - h_1)}{c_P(T_{hot} - T_{cold})}, \quad (8.70)$$

$$= \frac{\left(390 \frac{\text{lbm}}{\text{s}}\right) \left(\left(979.9 \frac{\text{Btu}}{\text{lbm}}\right) - \left(69.74 \frac{\text{Btu}}{\text{lbm}}\right) \right)}{\left(1.00 \frac{\text{Btu}}{\text{lbm} \cdot \text{°R}}\right) \left((80 \text{ °F}) - (60 \text{ °F}) \right)}, \quad (8.71)$$

$$= \boxed{17730 \frac{\text{lbm}}{\text{s}}}. \quad (8.72)$$

8.2 Brayton

Gas turbine power plants, both stationary and those for jet engines operate on the Brayton cycle. The cycle is named after George Brayton, an American mechanical engineer. Brayton



Figure 8.6: George Brayton (1830-1892), American mechanical engineer from Exeter, New Hampshire; image from https://en.wikipedia.org/wiki/George_Brayton.

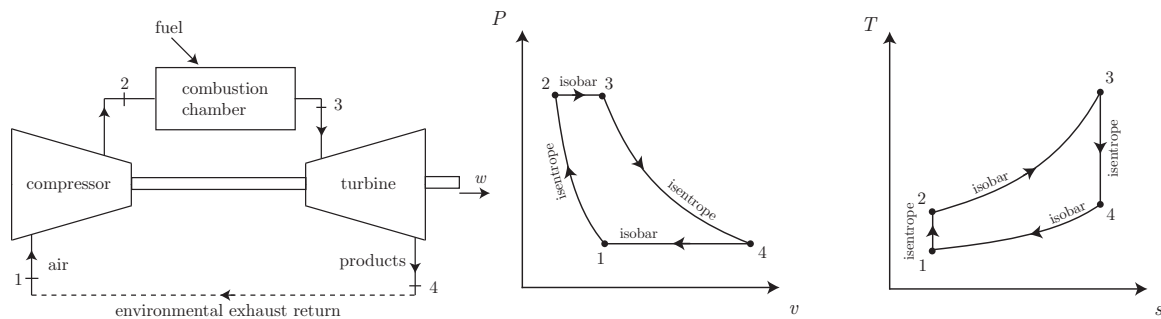

Figure 8.7: Schematic of Brayton cycle along with $P - v$ and $T - s$ diagrams.

is depicted in Fig. 8.6. It has many similarities to the Rankine cycle. A schematic and $T - s$ and $P - v$ diagrams for the Brayton cycle for a power plant are illustrated in Fig. 8.7.

The Brayton cycle is outlined as follows:

- 1 \rightarrow 2: isentropic compression (W added),
- 2 \rightarrow 3: isobaric heat addition (Q added),
- 3 \rightarrow 4: isentropic expansion (W extracted), and
- 4 \rightarrow 1: isobaric heat rejection (passive exhaust).

Note, the work extracted is greater than the work added, i.e.

$$|h_3 - h_4| > |h_2 - h_1|. \quad (8.73)$$

Often we will be dealing with a CPIG, in which case $\Delta h = c_P \Delta T$. If so, then we can say

$$|T_3 - T_4| > |T_2 - T_1|. \quad (8.74)$$

The reason for this is that

- *isobars diverge in $T - s$ space as s increases.*

This is easy to understand when we recall the Gibbs equation, Eq. (6.65): $T ds = dh - v dP$. On an isobar, we have $dP = 0$, so

$$T ds = dh, \quad \text{on isobar,} \quad (8.75)$$

$$= c_P dT, \quad \text{if IG,} \quad (8.76)$$

$$\left. \frac{\partial T}{\partial s} \right|_P = \frac{T}{c_P}. \quad (8.77)$$

Because at a given s , a high T isobar sits above a low T isobar, and the slope of the isobar is proportional to T , it is easily seen how they must diverge. This is illustrated in Fig. 8.8.

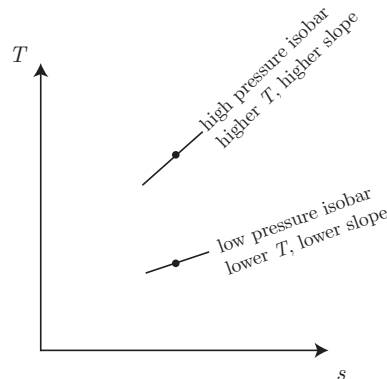

Figure 8.8: Sketch of diverging isobars for CPIG in $T - s$ plane.

There are other classes of Brayton cycle plants. Schematics are shown next.

- *Turbojet.* In the turbojet, the kinetic energy of the fluid becomes important at two points in the cycle. In the compression, the freestream fluid, entering the compressor at the flight speed, has its pressure increased by the so-called “ram effect” where the fluid decelerates. Second, the point of the turbojet is to produce thrust, that requires a significant exit velocity. The turbine work is used solely to power the compressor. See Fig. 8.9.
- *Turbojet with afterburners.* We are limited in an ordinary turbojet by how much heat can be added to the flow in combustion because such flow typically must pass through the turbine blades, that suffer material degradation if the fluid is too hot. However,

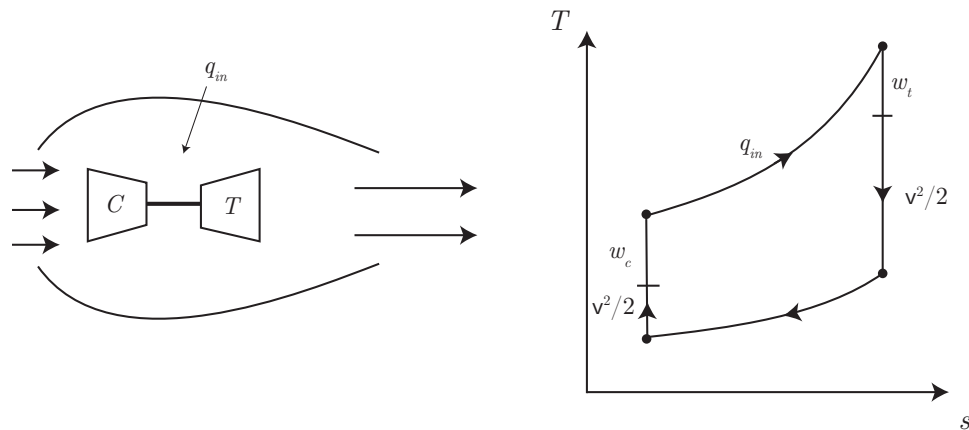

Figure 8.9: Sketch of turbojet schematic and associated $T - s$ plane.

we can add heat *after* the turbine in so-called *afterburners*. This releases chemical energy, turns it into fluid potential energy in the form of high P/ρ , and then converts to kinetic energy in the nozzle. This can enhance the thrust, though it can be shown it is not particularly efficient. A sketch is given in Fig. 8.10.

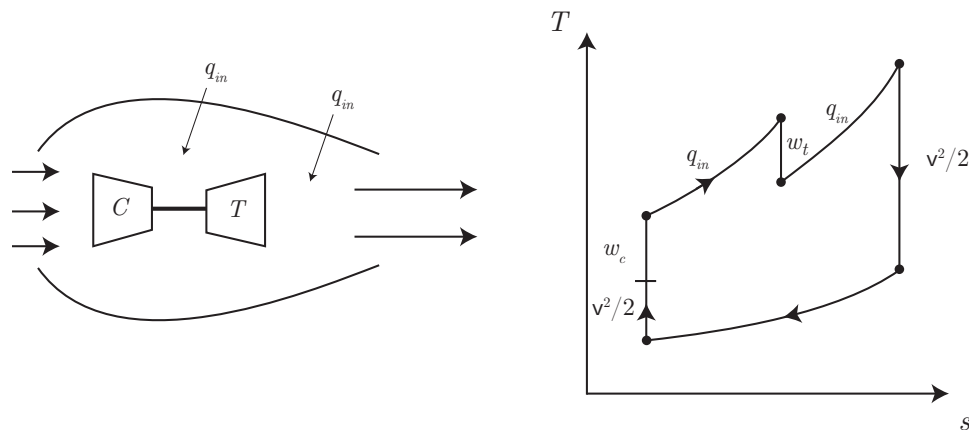

Figure 8.10: Sketch of turbojet with afterburners schematic and associated $T - s$ plane.

- *Ramjet*. A ramjet is much simpler. The compressor and turbine are removed. We rely on the ram compression effect alone for compression and convert as much of the thermal energy as possible into mechanical energy used to generate thrust force. A sketch is given in Fig. 8.11.

Let us consider an

- **AIR STANDARD ANALYSIS**: a common set of assumptions used for idealized cyclic devices.

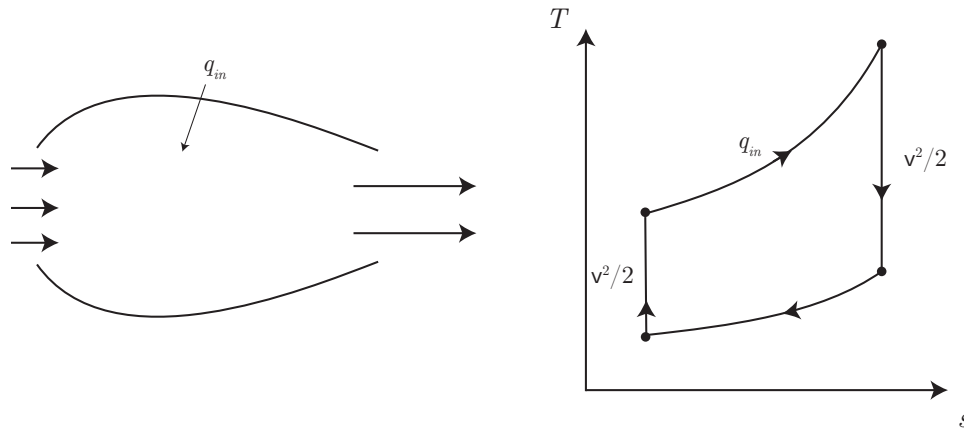

Figure 8.11: Sketch of ramjet schematic and associated $T - s$ plane.

The air standard make many compromises in order to admit some simple analysis tools to be used to make simple estimates for the performance of a variety of devices. Actual design calculations would have to remedy the many shortcomings. But it is useful for a framework of understanding. We take the air standard to entail

- The working fluid is air. This ignores any effect of the properties of the fuel or any other fluid that is mixed with the air.
- The working fluid is an ideal gas. We will often assume it is a CPIG, but sometimes not.
- We will ignore all details of the combustion process and treat it as a simple heat addition.

Often in cycle analysis, the formal sign convention is ignored. We take the following

- Turbine work: $w_t = h_3 - h_4$. Here, the sign convention is maintained.
- Compressor work: $w_c = h_2 - h_1$. Here, the sign convention is ignored.
- Heat addition: $q_{in} = h_3 - h_2$. Here, the sign convention is maintained.
- Heat rejection: $q_{out} = h_4 - h_1$. Here, the sign convention is ignored.

The cycle efficiency is

$$\eta = \frac{w_{net}}{q_{in}} = \frac{\underbrace{(h_3 - h_4)}_{\text{turbine}} - \underbrace{(h_2 - h_1)}_{\text{compressor}}}{\underbrace{h_3 - h_2}_{\text{combustor}}}. \quad (8.78)$$

Rearranging Eq. (8.78), we can also say

$$\eta = 1 - \frac{\overbrace{h_4 - h_1}^{\text{heat rejected}}}{\underbrace{h_3 - h_2}_{\text{heat added}}}. \quad (8.79)$$

The back work ratio, bwr , is the ratio of compressor to turbine work:

$$bwr = \frac{w_c}{w_t} = \frac{h_2 - h_1}{h_3 - h_4}. \quad (8.80)$$

Note the back work ratio will be seen to be much larger for gas phase power cycles than it was for vapor cycles. For Brayton cycles, we may see $bwr \sim 0.4$. For Rankine cycles, we usually see $bwr \sim 0.01$.

Now, if we have a CPIG, we get $\Delta h = \int c_P dT$ to reduce to $\Delta h = c_P \Delta T$. So Eq. (8.78) reduces to

$$\eta = \frac{c_P(T_3 - T_4) - c_P(T_2 - T_1)}{c_P(T_3 - T_2)}, \quad (8.81)$$

$$= \frac{T_3 - T_4 - T_2 + T_1}{T_3 - T_2}, \quad (8.82)$$

$$= 1 - \frac{T_4 - T_1}{T_3 - T_2}, \quad (8.83)$$

$$= 1 - \frac{T_1}{T_2} \left(\frac{\frac{T_4}{T_1} - 1}{\frac{T_3}{T_2} - 1} \right). \quad (8.84)$$

Now, $1 \rightarrow 2$ is isentropic. Recall from Eq. (6.169) for a CPIG that is isentropic that $T_2/T_1 = (P_2/P_1)^{(k-1)/k}$. We also have $3 \rightarrow 4$ to be isentropic, so $T_3/T_4 = (P_3/P_4)^{(k-1)/k}$. But $P_2 = P_3$ and $P_1 = P_4$. So

$$\frac{T_2}{T_1} = \frac{T_3}{T_4}, \quad (8.85)$$

$$\frac{T_4}{T_1} = \frac{T_3}{T_2}. \quad (8.86)$$

So

$$\eta = 1 - \frac{T_1}{T_2}. \quad (8.87)$$

With the temperature ratio θ across the compressor defined as

$$\theta = \frac{T_2}{T_1}, \quad (8.88)$$

we have

$$\eta = 1 - \frac{1}{\theta}. \quad (8.89)$$

In terms of the pressure ratio, the efficiency is

$$\eta = 1 - \frac{1}{\left(\frac{P_2}{P_1}\right)^{\frac{k-1}{k}}}. \quad (8.90)$$

A plot of η versus the temperature ratio θ is plotted in Fig. 8.12. As the temperature

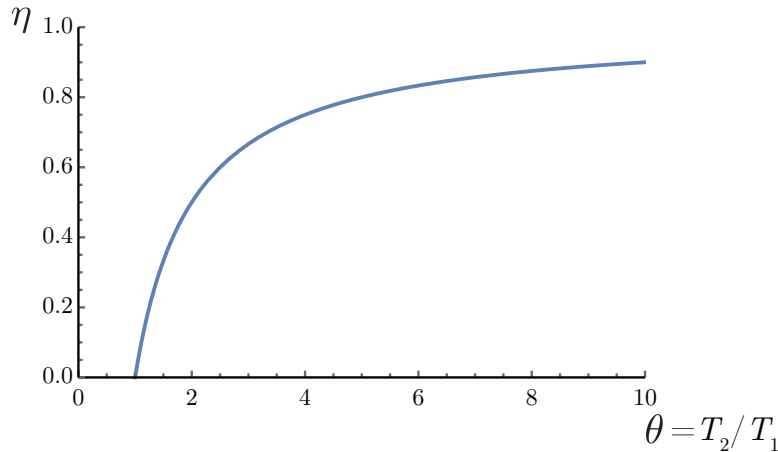

Figure 8.12: Thermal efficiency versus temperature ratio across the compressor for an air standard Brayton cycle.

ratio rises, the thermal efficiency increases for the Brayton cycle. For practical application, materials have temperature limits. Note the efficiency looks like that for a Carnot cycle, but it is not. The highest temperature in the Brayton cycle is T_3 , so the equivalent Carnot efficiency would be $1 - T_1/T_3$.

Example 8.4

Consider a CPIG air standard Brayton cycle with fixed inlet conditions P_1 and T_1 . We also fix the maximum temperature as the metallurgical limit of the turbine blades, T_{max} . Find the temperature ratio θ that maximizes the net work. Then find the temperature ratio that maximizes the thermal efficiency.

We have

$$T_2 = T_1\theta, \quad T_2 = T_1 \left(\frac{P_2}{P_1}\right)^{\frac{k-1}{k}}, \quad T_3 = T_{max}, \quad T_4 = T_3 \left(\frac{P_4}{P_3}\right)^{\frac{k-1}{k}}. \quad (8.91)$$

We also have $P_4 = P_1$ and $P_2 = P_3$. So

$$T_4 = T_{max} \left(\frac{P_1}{P_2} \right)^{\frac{k-1}{k}} = T_{max} \left(\frac{P_2}{P_1} \right)^{\frac{1-k}{k}} = \frac{T_{max}}{\theta}. \quad (8.92)$$

Now, the net work is

$$w_{net} = (h_3 - h_4) - (h_2 - h_1), \quad (8.93)$$

$$= c_P(T_3 - T_4 - T_2 + T_1), \quad (8.94)$$

$$= c_P(T_{max} - T_{max}\theta^{-1} - T_1\theta + T_1), \quad (8.95)$$

$$= c_P T_1 \left(\frac{T_{max}}{T_1} - \frac{T_{max}}{T_1} \theta^{-1} - \theta + 1 \right). \quad (8.96)$$

Note $w_{net} = 0$ when $\theta = 1$ and when $\theta = T_{max}/T_1$.

To find the maximum w_{net} we take $dw_{net}/d\theta$ and set to zero:

$$\frac{dw_{net}}{d\theta} = c_P T_1 \left(\frac{T_{max}}{T_1} \theta^{-2} - 1 \right), \quad (8.97)$$

$$0 = c_P T_1 \left(\frac{T_{max}}{T_1} \theta^{-2} - 1 \right), \quad (8.98)$$

$$\theta = \pm \sqrt{\frac{T_{max}}{T_1}}. \quad (8.99)$$

We take the positive root, because a negative temperature ratio does not make sense:

$$\boxed{\theta = \sqrt{\frac{T_{max}}{T_1}}}. \quad (8.100)$$

The second derivative tells us whether our critical point is a maximum or a minimum.

$$\frac{d^2 w_{net}}{d\theta^2} = -2c_P T_{max} \theta^{-3}. \quad (8.101)$$

When $\theta > 0$, $d^2 w_{net}/d\theta^2 < 0$, so we have found a maximum of w_{net} . The maximum value is

$$w_{net}|_{max} = c_P \left(T_{max} - T_{max} \left(\frac{T_{max}}{T_1} \right)^{-1/2} - T_1 \left(\frac{T_{max}}{T_1} \right)^{1/2} + T_1 \right), \quad (8.102)$$

$$= c_P T_1 \left(\frac{T_{max}}{T_1} - \frac{T_{max}}{T_1} \left(\frac{T_{max}}{T_1} \right)^{-1/2} - \left(\frac{T_{max}}{T_1} \right)^{1/2} + 1 \right), \quad (8.103)$$

$$= c_P T_1 \left(\frac{T_{max}}{T_1} - 2 \left(\frac{T_{max}}{T_1} \right)^{1/2} + 1 \right), \quad (8.104)$$

$$= c_P T_1 \left(\left(\frac{T_{max}}{T_1} \right)^{1/2} - 1 \right)^2. \quad (8.105)$$

Now, at what value of θ is the thermal efficiency maximum? Consider

$$\eta = 1 - \theta^{-1}, \quad (8.106)$$

$$\frac{d\eta}{d\theta} = \frac{1}{\theta^2}. \quad (8.107)$$

At a maximum, we must have $d\eta/d\theta = 0$. So we must have $\theta \rightarrow \infty$ in order to have η reach a maximum. But we are limited to $\theta \leq T_{max}/T_1$. So the achievable θ that maximizes η is

$$\boxed{\theta = \frac{T_{max}}{T_1}}. \quad (8.108)$$

So the efficiency at our highest allowable θ is

$$\eta = 1 - \frac{1}{\frac{T_{max}}{T_1}} = 1 - \frac{T_1}{T_{max}}. \quad (8.109)$$

But at the value of peak efficiency, the net work is approaching zero! So while this is highly efficient, it is not highly useful!

Lastly, what is the efficiency at the point where we maximize work?

$$\eta = 1 - \sqrt{\frac{T_1}{T_{max}}}. \quad (8.110)$$

A plot of scaled net work, $w_{net}/c_P/T_1$ versus temperature ratio is given for $T_{max}/T_1 = 10$ in Fig. 8.13. Here, the θ that maximizes w_{net} is $\theta = \sqrt{10} = 3.162$. At that value of θ , we find $\eta = 1 - \sqrt{1/10} =$

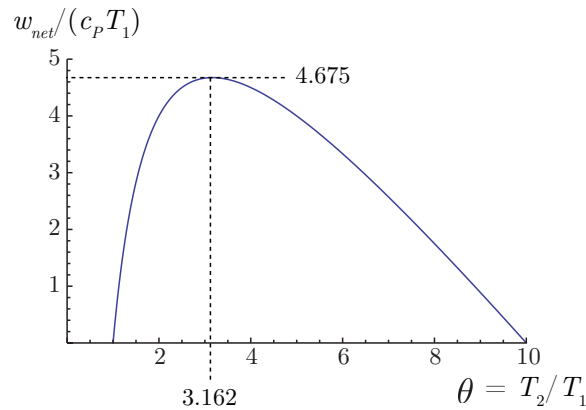

Figure 8.13: Scaled net work versus temperature ratio for Brayton cycle with $T_{max}/T_1 = 10$.

$$0.683772 \text{ and } w_{net}/c_P/T_1 = (\sqrt{10} - 1)^2 = 4.675.$$

Example 8.5

Consider the Brayton power cycle for a spacecraft sketched in Fig. 8.14. The working fluid is argon, that is well modeled as a CPIG over a wide range of T and P . We take the pressure in the heating process to be isobaric, $P_2 = P_3 = 140$ kPa, and the pressure in the cooling process to be isobaric, $P_4 = P_1 = 35$ kPa. We are given that $T_1 = 280$ K, $T_3 = 1100$ K. The compressor and turbine both have component efficiencies of $\eta_t = \eta_c = 0.8$. We are to find the net work, the thermal efficiency, and a plot of the process on a $T - s$ diagram.

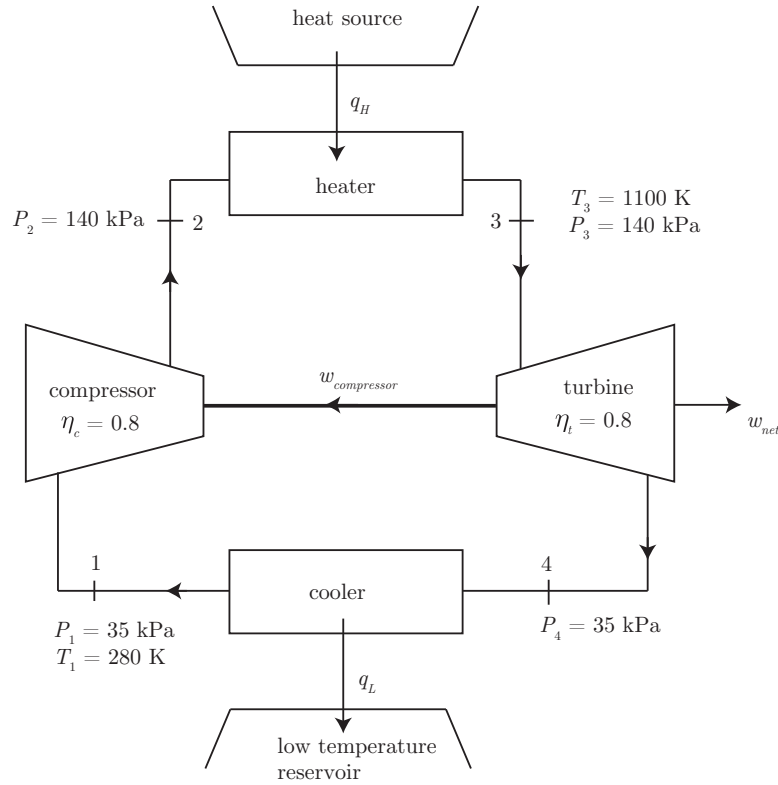

Figure 8.14: Schematic of Brayton power cycle for spacecraft.

For argon, we have

$$R = 0.20813 \frac{\text{kJ}}{\text{kg K}}, \quad c_P = 0.5203 \frac{\text{kJ}}{\text{kg K}}, \quad k = \frac{5}{3} \sim 1.667. \quad (8.111)$$

Note that $c_P = kR/(k-1)$.

Let us start at state 1. We first assume an isentropic compressor. We will quickly relax this to account for the compressor efficiency. But for an isentropic compressor, we have for the CPIG

$$\left(\frac{P_2}{P_1}\right)^{\frac{k-1}{k}} = \frac{T_{2s}}{T_1}. \quad (8.112)$$

Here, T_{2s} is the temperature that would be realized if the process were isentropic. We find

$$T_{2s} = T_1 \left(\frac{P_2}{P_1}\right)^{\frac{k-1}{k}} = (280 \text{ K}) \left(\frac{140 \text{ kPa}}{35 \text{ kPa}}\right)^{\frac{5/3-1}{5/3}} = 487.5 \text{ K}. \quad (8.113)$$

Now, $\eta_c = w_s/w_{\text{compressor}}$, so

$$w_{\text{compressor}} = \frac{w_s}{\eta_c} = \frac{h_{2s} - h_1}{\eta_c} = \frac{c_P(T_{2s} - T_1)}{\eta_c} = \frac{\left(0.5203 \frac{\text{kJ}}{\text{kg K}}\right) (487.5 \text{ K} - 280 \text{ K})}{0.8} = 135.0 \frac{\text{kJ}}{\text{kg}}. \quad (8.114)$$

Now $w_{\text{compressor}} = h_2 - h_1 = c_P(T_2 - T_1)$, so

$$T_2 = T_1 + \frac{w_{\text{compressor}}}{c_P} = (280 \text{ K}) + \frac{135.0 \frac{\text{kJ}}{\text{kg}}}{0.5203 \frac{\text{kJ}}{\text{kg K}}} = 539.5 \text{ K}. \quad (8.115)$$

Notice that $T_2 > T_{2s}$. The inefficiency (like friction) is manifested in more work being required to achieve the final pressure than that which would have been required had the process been ideal.

In the heater, we have

$$q_H = h_3 - h_2 = c_P(T_3 - T_2) = \left(0.5203 \frac{\text{kJ}}{\text{kg K}}\right) ((1100 \text{ K}) - (539.5 \text{ K})) = 291.6 \frac{\text{kJ}}{\text{kg}}. \quad (8.116)$$

Now, consider an ideal turbine:

$$\frac{T_{4s}}{T_3} = \left(\frac{P_4}{P_3}\right)^{\frac{k-1}{k}}, \quad (8.117)$$

$$T_{4s} = T_3 \left(\frac{P_4}{P_3}\right)^{\frac{k-1}{k}}, \quad (8.118)$$

$$= (1100 \text{ K}) \left(\frac{35 \text{ kPa}}{140 \text{ kPa}}\right)^{\frac{5/3-1}{5/3}}, \quad (8.119)$$

$$= 631.7 \text{ K}. \quad (8.120)$$

But for the real turbine,

$$\eta_t = \frac{w_{\text{turbine}}}{w_s}, \quad (8.121)$$

$$w_{\text{turbine}} = \eta_t w_s, \quad (8.122)$$

$$= \eta_t (h_3 - h_{4s}), \quad (8.123)$$

$$= \eta_t c_P (T_3 - T_{4s}), \quad (8.124)$$

$$= (0.8) \left(0.5203 \frac{\text{kJ}}{\text{kg K}}\right) ((1100 \text{ K}) - (631.7 \text{ K})) = 194.9 \frac{\text{kJ}}{\text{kg}}. \quad (8.125)$$

Thus, because $w_{\text{turbine}} = h_3 - h_4 = c_P(T_3 - T_4)$, we get

$$T_4 = T_3 - \frac{w_{\text{turbine}}}{c_P} = (1100 \text{ K}) - \frac{194.9 \frac{\text{kJ}}{\text{kg}}}{0.5203 \frac{\text{kJ}}{\text{kg K}}} = 725.4 \text{ K}. \quad (8.126)$$

Note that T_4 is higher than would be for an isentropic process. This indicates that we did not get all the possible work out of the turbine. Note also that some of the turbine work was used to drive the compressor, and the rest w_{net} is available for other uses. We find

$$w_{\text{net}} = w_{\text{turbine}} - w_{\text{compressor}} = \left(194.9 \frac{\text{kJ}}{\text{kg}}\right) - \left(135.0 \frac{\text{kJ}}{\text{kg}}\right) = \boxed{59.9 \frac{\text{kJ}}{\text{kg}}}. \quad (8.127)$$

Now, for the cooler,

$$q_L = h_4 - h_1 = c_P(T_4 - T_1) = \left(0.5203 \frac{\text{kJ}}{\text{kg K}}\right) ((725.4 \text{ K}) - (280 \text{ K})) = 231.7 \frac{\text{kJ}}{\text{kg}}. \quad (8.128)$$

We are now in a position to calculate the thermal efficiency for the cycle.

$$\eta = \frac{w_{net}}{q_H}, \quad (8.129)$$

$$= \frac{w_{turbine} - w_{compressor}}{q_H}, \quad (8.130)$$

$$= \frac{c_P((T_3 - T_4) - (T_2 - T_1))}{c_P(T_3 - T_2)}, \quad (8.131)$$

$$= \frac{(T_3 - T_4) - (T_2 - T_1)}{T_3 - T_2}, \quad (8.132)$$

$$= \frac{((1100 \text{ K}) - (725.4 \text{ K})) - ((539.5 \text{ K}) - (280 \text{ K}))}{(1100 \text{ K}) - (539.6 \text{ K})}, \quad (8.133)$$

$$= \boxed{0.205}. \quad (8.134)$$

If we had been able to employ a Carnot cycle operating between the same temperature bounds, we would have found the Carnot efficiency to be

$$\eta_{Carnot} = 1 - \frac{T_1}{T_3} = 1 - \frac{280 \text{ K}}{1100 \text{ K}} = 0.745 > 0.205. \quad (8.135)$$

A plot of the $T - s$ diagram for this Brayton cycle is shown in Fig. 8.15. Note that from 1 to 2 (as

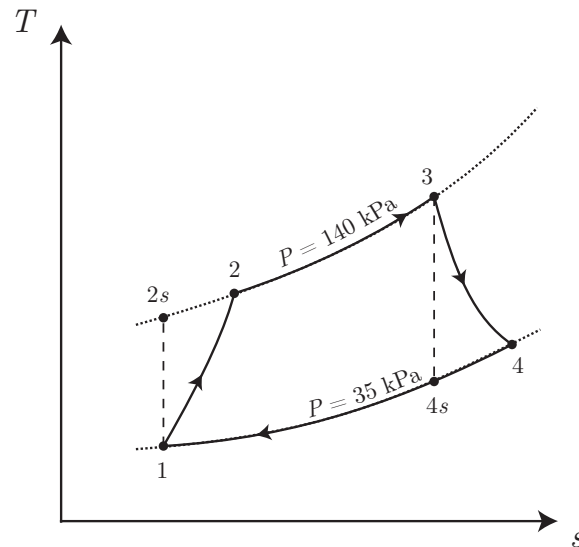

Figure 8.15: $T - s$ diagram of Brayton power cycle for spacecraft with turbine and compressor inefficiencies.

well as 3 to 4) there is area under the curve in the $T - s$ diagram. But the process is adiabatic! Recall that isentropic processes are both adiabatic and reversible. The 1-2 process is an example of a process that is adiabatic but irreversible. So the entropy change is not due to heat addition effects but instead is due to other effects.

Example 8.6

We are given a turbojet flying with a flight speed of 300 m/s. The compression ratio of the compressor is 7. The ambient air is at $T_a = 300$ K, $P_a = 100$ kPa. The turbine inlet temperature is 1500 K. The mass flow rate is $\dot{m} = 10$ kg/s. All of the turbine work is used to drive the compressor. Find the exit velocity and the thrust force generated. Assume an air standard with a CPIG; $k = 1.4$, $c_P = 1.0045$ kJ/kg/K.

A plot of the $T - s$ diagram for this Brayton cycle is shown in Fig. 8.16. We first calculate the ram

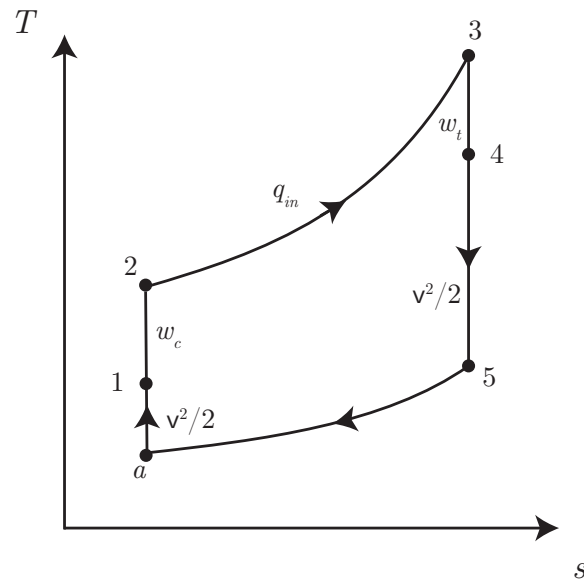

Figure 8.16: $T - s$ diagram of Brayton cycle in a turbojet engine.

compression effect:

$$h_1 + \underbrace{\frac{1}{2}v_1^2}_{\sim 0} = h_a + \frac{1}{2}v_a^2. \quad (8.136)$$

We typically neglect the kinetic energy of the flow once it has been brought to near rest within the engine. So we get

$$h_1 - h_a = \frac{1}{2}v_a^2, \quad (8.137)$$

$$c_P(T_1 - T_a) = \frac{1}{2}v_a^2, \quad (8.138)$$

$$T_1 = T_a + \frac{v_a^2}{2c_P}, \quad (8.139)$$

$$= (300 \text{ K}) + \frac{(300 \frac{\text{m}}{\text{s}})^2}{2 \left(1.0045 \frac{\text{kJ}}{\text{kg K}}\right)} \frac{\text{kJ}}{1000 \frac{\text{m}^2}{\text{s}^2}}, \quad (8.140)$$

$$= 344.8 \text{ K}. \quad (8.141)$$

Now, consider the isentropic compression in the compressor. For this, we have

$$\frac{T_2}{T_1} = \left(\underbrace{\frac{P_2}{P_1}}_{=7} \right)^{\frac{k-1}{k}}, \quad (8.142)$$

$$T_2 = (344.8 \text{ K})(7)^{\frac{1.4-1}{1.4}}, \quad (8.143)$$

$$= 601.27 \text{ K}. \quad (8.144)$$

Let us calculate P_2/P_a , that we will need later. From the isentropic relations,

$$\frac{P_2}{P_a} = \left(\frac{T_2}{T_a} \right)^{\frac{k}{k-1}}, \quad (8.145)$$

$$= \left(\frac{601.27 \text{ K}}{300 \text{ K}} \right)^{\frac{1.4}{1.4-1}}, \quad (8.146)$$

$$= 11.3977. \quad (8.147)$$

We were given the turbine inlet temperature, $T_3 = 1500 \text{ K}$. Now, the compressor work must equal the turbine work. This amounts to, ignoring the sign convention,

$$w_c = w_t, \quad (8.148)$$

$$h_2 - h_1 = h_3 - h_4, \quad (8.149)$$

$$c_P(T_2 - T_1) = c_P(T_3 - T_4), \quad (8.150)$$

$$T_2 - T_1 = T_3 - T_4, \quad (8.151)$$

$$T_4 = T_3 - T_2 + T_1, \quad (8.152)$$

$$= (1500 \text{ K}) - (601.27 \text{ K}) + (344.8 \text{ K}), \quad (8.153)$$

$$= 1243.5 \text{ K}. \quad (8.154)$$

Now, we use the isentropic relations to get T_5 . Process 3 to 5 is isentropic with $P_5/P_3 = P_a/P_2 = 1/11.3977$, so we have

$$\frac{P_5}{P_3} = \left(\frac{T_5}{T_3} \right)^{\frac{k}{k-1}}, \quad (8.155)$$

$$T_5 = T_3 \left(\frac{P_5}{P_3} \right)^{\frac{k-1}{k}}, \quad (8.156)$$

$$= (1500 \text{ K}) \left(\frac{1}{11.3977} \right)^{\frac{1.4-1}{1.4}}, \quad (8.157)$$

$$= 748.4 \text{ K}. \quad (8.158)$$

Now, we need to calculate the exhaust velocity. Take an energy balance through the nozzle to get

$$h_4 + \frac{1}{2} \underbrace{v_4^2}_{\sim 0} = h_5 + \frac{1}{2} v_5^2, \quad (8.159)$$

$$h_4 = h_5 + \frac{1}{2} v_5^2, \quad (8.160)$$

$$v_5 = \sqrt{2(h_4 - h_5)}, \quad (8.161)$$

$$= \sqrt{2c_P(T_4 - T_5)}, \quad (8.162)$$

$$= \sqrt{2 \left(1.0045 \frac{\text{kJ}}{\text{kg K}} \right) ((1243.5 \text{ K}) - (748.4 \text{ K})) \frac{1000 \frac{\text{m}^2}{\text{s}^2}}{\frac{\text{kJ}}{\text{kg}}}}, \quad (8.163)$$

$$= \boxed{997.3 \frac{\text{m}}{\text{s}}}. \quad (8.164)$$

Now, Newton's second law for a control volume can be derived by applying the methods of Sec. 4.1. Leaving out details, it can be shown for one dimensional flow with one inlet and exit to be

$$\frac{d}{dt}(\rho v) = F_{cv} + \dot{m}v_i - \dot{m}v_e. \quad (8.165)$$

It says the time rate of change of momentum in the control volume is the net force acting on the control volume plus the momentum brought in minus the momentum that leaves. Often terms of the form $\dot{m}v$ are known as *momentum flux*. We will take the problem to be steady and take the force to be the thrust force. So

$$F_{cv} = \dot{m}(v_e - v_i), \quad (8.166)$$

$$= \dot{m}(v_5 - v_a), \quad (8.167)$$

$$= \left(10 \frac{\text{kg}}{\text{s}} \right) \left(\left(997.3 \frac{\text{m}}{\text{s}} \right) - \left(300 \frac{\text{m}}{\text{s}} \right) \right), \quad (8.168)$$

$$= \boxed{6973 \text{ N}}. \quad (8.169)$$

8.3 Refrigeration

A simple way to think of a refrigerator is a cyclic heat engine operating in reverse. Rather than extracting work from heat transfer from a high temperature reservoir and rejecting heat to a low temperature reservoir, the refrigerator takes a work input to move heat from a low temperature reservoir to a high temperature reservoir.

A common refrigerator is based on a vapor-compression cycle. This is a Rankine cycle in reverse. While one could employ a turbine to extract some work, it is often impractical. Instead the high pressure gas is simply irreversibly throttled down to low pressure.

One can outline the vapor-compression refrigeration cycle as follows:

- 1 → 2: isentropic compression

- 2 \rightarrow 3: isobaric heat transfer to high temperature reservoir in condenser,
- 3 \rightarrow 4: adiabatic expansion in throttling valve, and
- 4 \rightarrow 1: isobaric (and often isothermal) heat transfer from a low temperature reservoir to an evaporator.

A schematic and associated $T - s$ diagram for the vapor-compression refrigeration cycle is shown in Fig. 8.17. One goal in design of refrigerators is low work input. There are two

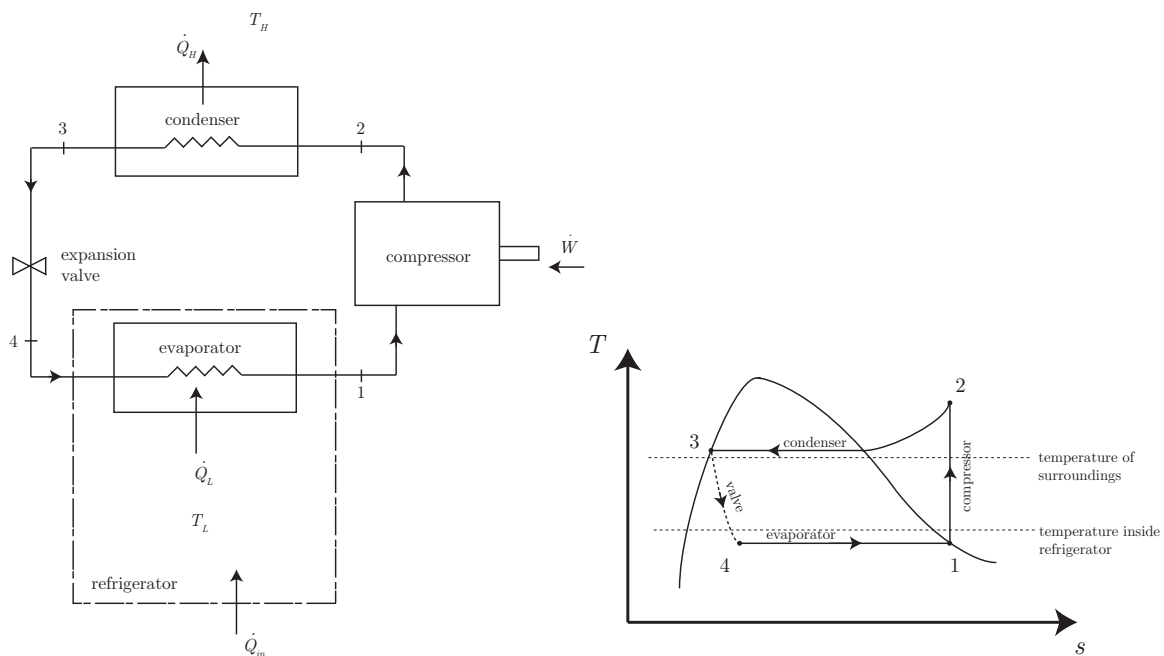

Figure 8.17: Schematic and $T - s$ diagrams for the vapor-compression refrigeration cycle.

main strategies in this:

- Design the best refrigerator to minimize \dot{Q}_{in} . This really means reducing the conductive heat flux through the refrigerator walls. One can use a highly insulating material. One can also use thick walls. Thick walls will reduce available space for storage however. This is an example of a design trade-off.
- For a given \dot{Q}_{in} , design the optimal thermodynamic cycle to minimize the work necessary to achieve the goal. In practice, this means making the topology of the cycle as much as possible resemble that of a Carnot refrigerator. Our vapor compression refrigeration cycle is actually close to a Carnot cycle.

The efficiency does not make sense for a refrigerator as $0 \leq \eta \leq 1$. Instead, much as our earlier analysis for Carnot refrigerators, a coefficient of performance, β , is defined as

$$\beta = \frac{\text{what one wants}}{\text{what one pays for}}, \quad (8.170)$$

$$= \frac{q_L}{w_c}. \quad (8.171)$$

Note that a heat pump is effectively the same as a refrigerator, except one desires q_H rather than q_L . So for a heat pump, the coefficient of performance, β' , is defined as

$$\beta' = \frac{q_H}{w_c}. \quad (8.172)$$

Example 8.7

R-134a, a common refrigerant, enters a compressor at $x_1 = 1$, $T_1 = -15^\circ\text{C}$. At the compressor inlet, the volume flow rate is $1 \text{ m}^3/\text{min}$. The R-134a leaves the condenser at $T_3 = 35^\circ\text{C}$, $P_3 = 1000 \text{ kPa}$. Analyze the system.

We have the state at 1, knowing x_1 and T_1 . The tables then give

$$h_1 = 389.20 \frac{\text{kJ}}{\text{kg}}, \quad s_1 = 1.7354 \frac{\text{kJ}}{\text{kg K}}, \quad v_1 = 0.12007 \frac{\text{m}^3}{\text{kg}}. \quad (8.173)$$

The process 2 to 3 is along an isobar. We know $P_3 = 1000 \text{ kPa}$, so $P_2 = 1000 \text{ kPa}$. We assume an isentropic compression to state 2, where $P_2 = 1000 \text{ kPa}$. We have $s_2 = s_1 = 1.7354 \text{ kJ/kg/K}$. We interpolate the superheat tables to get

$$h_2 = 426.771 \frac{\text{kJ}}{\text{kg}}. \quad (8.174)$$

State 3 is a subcooled liquid, and we have no tables for it. Let us approximate h_3 as h_f at $T_3 = 35^\circ\text{C}$, that is

$$h_3 \sim 249.10 \frac{\text{kJ}}{\text{kg}}. \quad (8.175)$$

In the expansion valve, we have

$$h_4 = h_3 = 249.10 \frac{\text{kJ}}{\text{kg}}. \quad (8.176)$$

Now,

$$\dot{m} = \rho Av = \frac{Av}{v_1} = \left(\frac{1 \frac{\text{m}^3}{\text{min}}}{0.12007 \frac{\text{m}^3}{\text{kg}}} \right) \left(\frac{\text{min}}{60 \text{ s}} \right) = 0.138808 \frac{\text{kg}}{\text{s}}. \quad (8.177)$$

Note the term Av has units m^3/s and is a volume flow rate. Now, the compressor power is

$$\dot{W} = \dot{m}(h_2 - h_1) = \left(0.138808 \frac{\text{kg}}{\text{s}} \right) \left(\left(426.771 \frac{\text{kJ}}{\text{kg}} \right) - \left(389.20 \frac{\text{kJ}}{\text{kg}} \right) \right) = 5.2152 \text{ kW}. \quad (8.178)$$

The refrigerator capacity is

$$\dot{Q}_{in} = \dot{m}(h_1 - h_4) = \left(0.138808 \frac{\text{kg}}{\text{s}} \right) \left(\left(389.20 \frac{\text{kJ}}{\text{kg}} \right) - \left(249.10 \frac{\text{kJ}}{\text{kg}} \right) \right) = 19.447 \text{ kW}. \quad (8.179)$$

With a 5.2152 kW input, we will move 19.447 kW out of the refrigerator.

At what rate does heat exit the back side?

$$\dot{Q}_H = \dot{m}(h_2 - h_3) = \left(0.138808 \frac{\text{kg}}{\text{s}}\right) \left(\left(426.771 \frac{\text{kJ}}{\text{kg}}\right) - \left(249.10 \frac{\text{kJ}}{\text{kg}}\right)\right) = 24.6622 \text{ kW}. \quad (8.180)$$

Note that

$$\dot{Q}_H = \dot{Q}_{in} + \dot{W}, \quad (8.181)$$

$$24.6622 \text{ kW} = (19.447 \text{ kW}) + (5.2152 \text{ kW}). \quad (8.182)$$

The coefficient of performance is

$$\beta = \frac{\dot{Q}_{in}}{\dot{W}} = \frac{19.447 \text{ kW}}{5.2152 \text{ kW}} = 3.72891. \quad (8.183)$$

We could also say

$$\beta = \frac{\dot{Q}_{in}}{\dot{Q}_H - \dot{Q}_{in}}, \quad (8.184)$$

$$= \frac{1}{\frac{\dot{Q}_H}{\dot{Q}_{in}} - 1}. \quad (8.185)$$

Because we do not have a Carnot refrigerator for this problem, we realize that $\dot{Q}_H/\dot{Q}_{in} \neq T_3/T_1$.

The University of Notre Dame Power Plant also serves as a generator of chilled water for air conditioning campus buildings. This is effectively a refrigerator on a grand scale, though we omit details of the actual system here. A photograph of one of the campus chillers is shown in Fig. 8.18.



Figure 8.18: Chiller in the University of Notre Dame power plant, 14 June 2010.

Chapter 9

Mathematical foundations

Read BS, Chapters 12, 15

This chapter will serve as an introduction to some of the mathematical underpinnings of thermodynamics. Though the practicality is not immediately obvious to all, this analysis is a necessary precursor for building many useful and standard theories. Important among those are theories to describe chemical reactions, that have widespread application in a variety of engineering scenarios, including combustion, materials processing, and pollution control.

9.1 Maxwell relations

We begin with a discussion of the so-called Maxwell¹ relations, named after the great nineteenth century physicist, James Clerk Maxwell, shown in Fig. 9.1.



Figure 9.1: James Clerk Maxwell (1831-1879) Scottish physicist; image from <http://mathshistory.st-andrews.ac.uk/Biographies/Maxwell.html>.

¹J. C. Maxwell, 1871, *Theory of Heat*, reprinted 2001, Dover, Mineola, New York, p. 169.

Recall that if $z = z(x, y)$, we have Eq. (3.3):

$$dz = \left. \frac{\partial z}{\partial x} \right|_y dx + \left. \frac{\partial z}{\partial y} \right|_x dy. \quad (9.1)$$

Recall if $dz = M(x, y) dx + N(x, y) dy$, the requirement for an exact differential is

$$\left. \frac{\partial z}{\partial x} \right|_y = M, \quad \left. \frac{\partial z}{\partial y} \right|_x = N, \quad (9.2)$$

$$\left. \frac{\partial^2 z}{\partial y \partial x} \right|_x = \left. \frac{\partial M}{\partial y} \right|_x, \quad \left. \frac{\partial^2 z}{\partial x \partial y} \right|_y = \left. \frac{\partial N}{\partial x} \right|_y. \quad (9.3)$$

These equations are the same as Eqs. (3.7, 3.8). Because order of differentiation does not matter for functions that are continuous and differentiable, we must have for exact differentials, Eq. (3.9):

$$\left. \frac{\partial N}{\partial x} \right|_y = \left. \frac{\partial M}{\partial y} \right|_x. \quad (9.4)$$

Compare the Gibbs equation, Eq. (6.59), to our equation for dz :

$$du = -P dv + T ds, \quad (9.5)$$

$$dz = M dx + N dy. \quad (9.6)$$

We see the equivalences

$$z \rightarrow u, \quad x \rightarrow v, \quad y \rightarrow s, \quad M \rightarrow -P, \quad N \rightarrow T, \quad (9.7)$$

and just as one expects $z = z(x, y)$, one then expects the natural, or *canonical* form of

$$u = u(v, s). \quad (9.8)$$

Application of Eq. (9.4) to the Gibbs equation, Eq. (6.59), gives then

$$\left. \frac{\partial T}{\partial v} \right|_s = - \left. \frac{\partial P}{\partial s} \right|_v. \quad (9.9)$$

Equation (9.9) is known as a *Maxwell relation*. Moreover, specialization of Eq. (9.2) to the Gibbs equation gives

$$\left. \frac{\partial u}{\partial v} \right|_s = -P, \quad \left. \frac{\partial u}{\partial s} \right|_v = T. \quad (9.10)$$

9.2 Functions of two independent variables

Consider a general implicit function linking three variables, x , y , z :

$$f(x, y, z) = 0. \quad (9.11)$$

In $x - y - z$ space, this will represent a surface. If the function can be inverted, it will be possible to write the explicit forms

$$x = x(y, z), \quad y = y(x, z), \quad z = z(x, y). \quad (9.12)$$

Differentiating the first two of Eqs. (9.12) gives

$$dx = \left. \frac{\partial x}{\partial y} \right|_z dy + \left. \frac{\partial x}{\partial z} \right|_y dz, \quad (9.13)$$

$$dy = \left. \frac{\partial y}{\partial x} \right|_z dx + \left. \frac{\partial y}{\partial z} \right|_x dz. \quad (9.14)$$

Now, use Eq. (9.14) to eliminate dy in Eq. (9.13):

$$dx = \left. \frac{\partial x}{\partial y} \right|_z \underbrace{\left(\left. \frac{\partial y}{\partial x} \right|_z dx + \left. \frac{\partial y}{\partial z} \right|_x dz \right)}_{=dy} + \left. \frac{\partial x}{\partial z} \right|_y dz, \quad (9.15)$$

$$\left(1 - \left. \frac{\partial x}{\partial y} \right|_z \left. \frac{\partial y}{\partial x} \right|_z \right) dx = \left(\left. \frac{\partial x}{\partial y} \right|_z \left. \frac{\partial y}{\partial z} \right|_x + \left. \frac{\partial x}{\partial z} \right|_y \right) dz, \quad (9.16)$$

$$0 dx + 0 dz = \underbrace{\left(\left. \frac{\partial x}{\partial y} \right|_z \left. \frac{\partial y}{\partial x} \right|_z - 1 \right)}_{=0} dx + \underbrace{\left(\left. \frac{\partial x}{\partial y} \right|_z \left. \frac{\partial y}{\partial z} \right|_x + \left. \frac{\partial x}{\partial z} \right|_y \right)}_{=0} dz. \quad (9.17)$$

Because x and z are independent, so are dx and dz , and the coefficients on each in Eq. (9.17) must be zero. Therefore, from the coefficient on dx in Eq. (9.17), we have

$$\left. \frac{\partial x}{\partial y} \right|_z \left. \frac{\partial y}{\partial x} \right|_z - 1 = 0, \quad (9.18)$$

$$\left. \frac{\partial x}{\partial y} \right|_z \left. \frac{\partial y}{\partial x} \right|_z = 1, \quad (9.19)$$

$$\left. \frac{\partial x}{\partial y} \right|_z = \frac{1}{\left. \frac{\partial y}{\partial x} \right|_z}, \quad (9.20)$$

and also from the coefficient on dz in Eq. (9.17), we have

$$\left. \frac{\partial x}{\partial y} \right|_z \left. \frac{\partial y}{\partial z} \right|_x + \left. \frac{\partial x}{\partial z} \right|_y = 0, \quad (9.21)$$

$$\left. \frac{\partial x}{\partial z} \right|_y = - \left. \frac{\partial x}{\partial y} \right|_z \left. \frac{\partial y}{\partial z} \right|_x, \quad (9.22)$$

$$\left. \frac{\partial x}{\partial z} \right|_y \left. \frac{\partial y}{\partial x} \right|_z \left. \frac{\partial z}{\partial y} \right|_x = -1. \quad (9.23)$$

If one now divides Eq. (9.13) by a fourth differential, dw , one gets

$$\frac{dx}{dw} = \left. \frac{\partial x}{\partial y} \right|_z \frac{dy}{dw} + \left. \frac{\partial x}{\partial z} \right|_y \frac{dz}{dw}. \quad (9.24)$$

Demanding that z be held constant in Eq. (9.24) gives

$$\left. \frac{\partial x}{\partial w} \right|_z = \left. \frac{\partial x}{\partial y} \right|_z \left. \frac{\partial y}{\partial w} \right|_z, \quad (9.25)$$

$$\left. \frac{\frac{\partial x}{\partial w}}{\frac{\partial y}{\partial w}} \right|_z = \left. \frac{\partial x}{\partial y} \right|_z, \quad (9.26)$$

$$\left. \frac{\partial x}{\partial w} \right|_z \left. \frac{\partial w}{\partial y} \right|_z = \left. \frac{\partial x}{\partial y} \right|_z. \quad (9.27)$$

If $x = x(y, w)$, one then gets

$$dx = \left. \frac{\partial x}{\partial y} \right|_w dy + \left. \frac{\partial x}{\partial w} \right|_y dw. \quad (9.28)$$

Divide now by dy while holding z constant so

$$\left. \frac{\partial x}{\partial y} \right|_z = \left. \frac{\partial x}{\partial y} \right|_w + \left. \frac{\partial x}{\partial w} \right|_y \left. \frac{\partial w}{\partial y} \right|_z. \quad (9.29)$$

These general operations can be applied to a wide variety of thermodynamic operations.

9.3 Legendre transformations

The Gibbs equation, Eq. (6.59): $du = -P dv + T ds$, is the fundamental equation of classical thermodynamics. It is a canonical form that suggests the most natural set of variables in which to express internal energy u are v and s :

$$u = u(v, s). \quad (9.30)$$

However, v and s may not be convenient for a particular problem. There may be other combinations of variables whose canonical form gives a more convenient set of independent variables for a particular problem. An example is the enthalpy, Eq. (3.204):

$$h = u + Pv. \quad (9.31)$$

Differentiating the enthalpy gives

$$dh = du + P dv + v dP. \quad (9.32)$$

We repeat the analysis used to obtain Eq. (6.66) earlier. Use Eq. (9.32) to eliminate du in the Gibbs equation, Eq. (6.59), to give

$$\underbrace{dh - P dv - v dP}_{=du} = -P dv + T ds, \quad (9.33)$$

$$dh = T ds + v dP. \quad (9.34)$$

So the canonical variables for h are s and P . One then expects

$$h = h(s, P). \quad (9.35)$$

This exercise can be systematized with the Legendre transformation, details of which we will omit. The interested student can consult Zia, *et al.*² or Abbott and van Ness.³ The transformation is named after Adrien-Marie Legendre, whose work was not motivated by thermodynamic concerns, but has found application in thermodynamics. The only known image of Legendre is shown in Fig. 9.2.

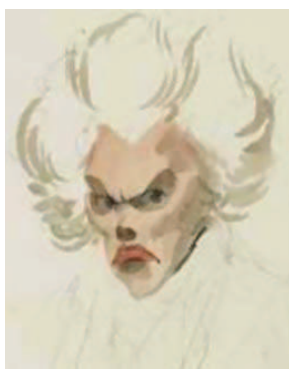

Figure 9.2: Adrien-Marie Legendre (1752-1833) French mathematician; image from <http://mathshistory.st-andrews.ac.uk/Biographies/Legendre.html>.

²R. K. P. Zia, E. F. Redish, and S. R. McKay, 2009, “Making sense of the Legendre transform,” *American Journal of Physics*, 77(7): 614-622.

³M. M. Abbott and H. C. van Ness, 1972, *Thermodynamics*, Schaum’s Outline Series in Engineering, McGraw-Hill, New York.

The basic outline of the Legendre transformation is as follows. The form $du = -P dv + T ds$, suggests u is the fundamental dependent variable, v and s are the canonical independent variables, with $-P$ and T serving as so-called *conjugate variables*. We seek transformations that can render conjugate variables to be canonical variables. We can achieve this by defining new dependent variables as the difference between the original dependent variable and simple second order combinations of the canonical and conjugate variables. For the Gibbs equation, there are only three combinations, $-Pv$, Ts , and $-Pv + Ts$, that are dimensionally consistent with u . We subtract each of these from u to define new dependent variables as follows: They are

$$h = h(P, s) = u - (-Pv) = u + Pv, \quad \text{enthalpy,} \quad (9.36)$$

$$a = a(v, T) = u - (Ts) = u - Ts, \quad \text{Helmholtz free energy,} \quad (9.37)$$

$$g = g(P, T) = u - (-Pv + Ts) = u + Pv - Ts, \quad \text{Gibbs free energy.} \quad (9.38)$$

The Helmholtz free energy was developed by Helmholtz.⁴ It is symbolized by a in recognition of the German word *arbeit*, or “work.” An image of the original appearance of the notion from Helmholtz’s 1882 work is shown in Fig. 9.3. The notation \mathfrak{F} is our Helmholtz free energy a ; U is our u ; \mathfrak{J} is our mechanical equivalent of heat \mathcal{J} ; ϑ is our temperature T ; and S is our entropy s . The Gibbs free energy was introduced by Gibbs.⁵ An image of a somewhat roundabout appearance of the Gibbs free energy from Gibbs’ 1873 work is shown in Fig. 9.4. Here, ϵ is our u , E is our U , η is our s , and H is our S .

It has already been shown for the enthalpy that $dh = T ds + v dP$, so that the canonical variables are s and P . One then also has

$$dh = \left. \frac{\partial h}{\partial s} \right|_P ds + \left. \frac{\partial h}{\partial P} \right|_s dP, \quad (9.39)$$

from which one deduces that

$$T = \left. \frac{\partial h}{\partial s} \right|_P, \quad v = \left. \frac{\partial h}{\partial P} \right|_s. \quad (9.40)$$

From Eq. (9.40), a second Maxwell relation can be deduced by differentiation of the first with respect to P and the second with respect to s :

$$\left. \frac{\partial T}{\partial P} \right|_s = \left. \frac{\partial v}{\partial s} \right|_P. \quad (9.41)$$

The relations for Helmholtz and Gibbs free energies each supply additional useful relations

⁴H. Helmholtz, 1882, “Die Thermodynamik chemischer Vorgänge,” *Sitzungsberichte der Königlich Preussischen Akademie der Wissenschaften zu Berlin*, 1: 22-39.

⁵J. W. Gibbs, 1873, “A method of geometrical representation of the thermodynamic properties of substances by means of surfaces,” *Transactions of the Connecticut Academy of Arts and Sciences*, 2: 382-404.

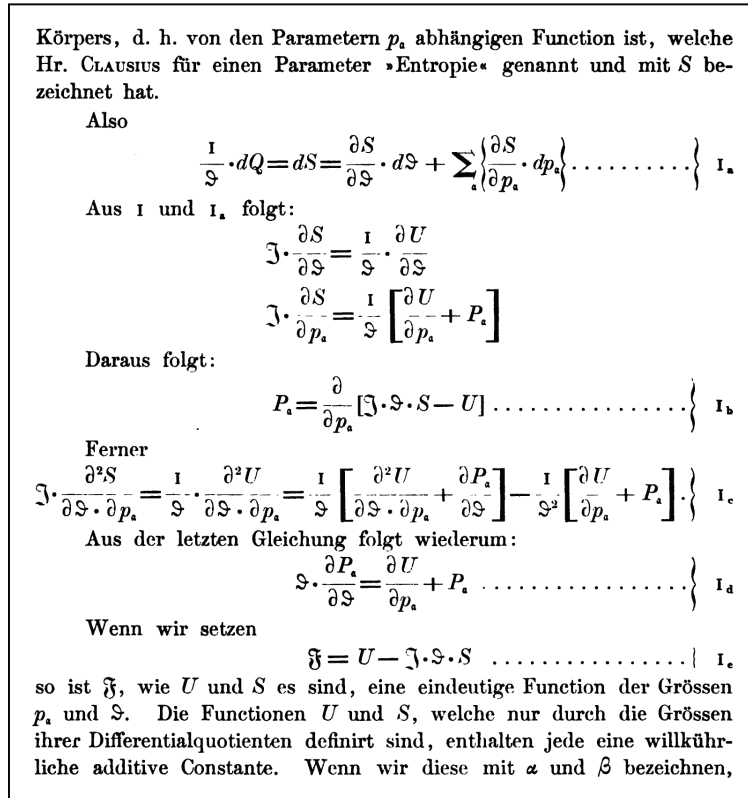

Figure 9.3: Image of the original 1882 appearance of the Helmholtz free energy.

including two new Maxwell relations. First consider the Helmholtz free energy

$$a = u - Ts, \tag{9.42}$$

$$da = du - T ds - s dT, \tag{9.43}$$

$$= \underbrace{(-P dv + T ds)}_{du} - T ds - s dT, \tag{9.44}$$

$$= -P dv - s dT. \tag{9.45}$$

So the canonical variables for a are v and T . The conjugate variables are $-P$ and $-s$. Thus

$$da = \left. \frac{\partial a}{\partial v} \right|_T dv + \left. \frac{\partial a}{\partial T} \right|_v dT. \tag{9.46}$$

So one gets

$$-P = \left. \frac{\partial a}{\partial v} \right|_T, \quad -s = \left. \frac{\partial a}{\partial T} \right|_v. \tag{9.47}$$

and the consequent Maxwell relation

$$\left. \frac{\partial P}{\partial T} \right|_v = \left. \frac{\partial s}{\partial v} \right|_T. \tag{9.48}$$

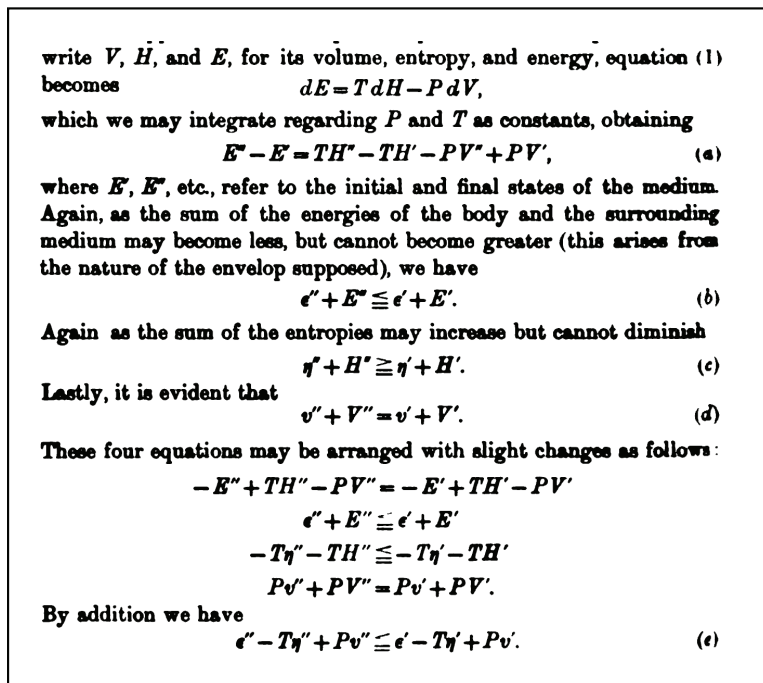

Figure 9.4: Image of the original 1873 appearance of a combination of terms that is now known as the Gibbs free energy.

For the Gibbs free energy

$$g = \underbrace{u + Pv}_{=h} - Ts, \quad (9.49)$$

$$= h - Ts, \quad (9.50)$$

$$dg = dh - T ds - s dT, \quad (9.51)$$

$$= \underbrace{(T ds + v dP)}_{=dh} - T ds - s dT, \quad (9.52)$$

$$= v dP - s dT. \quad (9.53)$$

Many find some of these equations to have sufficient appeal to cast them in concrete. The extensive version of Eq. (9.51), unfortunately restricted to the isothermal limit, is depicted in the floor of University of Notre Dame's Jordan Hall of Science atrium, see Fig. 9.5.

So for Gibbs free energy, the canonical variables are P and T , while the conjugate variables are v and $-s$. One then has $g = g(P, T)$, that gives

$$dg = \left. \frac{\partial g}{\partial P} \right|_T dP + \left. \frac{\partial g}{\partial T} \right|_P dT. \quad (9.54)$$

So one finds

$$v = \left. \frac{\partial g}{\partial P} \right|_T, \quad -s = \left. \frac{\partial g}{\partial T} \right|_P. \quad (9.55)$$



Figure 9.5: Figure cast in the atrium floor of the University of Notre Dame’s Jordan Hall of Science containing an isothermal extensive version of Eq. (9.51), among other things.

| | | | |
|--|---|---|---|
| $u = u$ | $h = u + Pv$ | $a = u - Ts$ | $g = u + Pv - Ts$ |
| $du = -P dv + T ds$ | $dh = T ds + v dP$ | $da = -P dv - s dT$ | $dg = v dP - s dT$ |
| $u = u(v, s)$ | $h = h(s, P)$ | $a = a(v, T)$ | $g = g(P, T)$ |
| $-\left. \frac{\partial P}{\partial s} \right _v = \left. \frac{\partial T}{\partial v} \right _s$ | $\left. \frac{\partial T}{\partial P} \right _s = \left. \frac{\partial v}{\partial s} \right _P$ | $\left. \frac{\partial P}{\partial T} \right _v = \left. \frac{\partial s}{\partial v} \right _T$ | $\left. \frac{\partial v}{\partial T} \right _P = - \left. \frac{\partial s}{\partial P} \right _T$ |

Table 9.1: Summary of Maxwell relations and their generators.

The resulting Maxwell relation is then

$$\left. \frac{\partial v}{\partial T} \right|_P = - \left. \frac{\partial s}{\partial P} \right|_T. \quad (9.56)$$

Table 9.1 gives a summary of the Maxwell relations and their generators. An image showing the first published appearance of the Maxwell relations is given in Fig. 9.6. In Fig. 9.6, the “thermodynamic function” ϕ is our s , and θ is our T . Note that typography for partial derivatives was non-existent in most texts of the nineteenth century. Additional discussion of Legendre transformations is given in the Appendix.

¹ These four relations may be concisely expressed in the language of the Differential Calculus as follows:

$$\frac{d v}{d \theta} (p \text{ const.}) = - \frac{d \phi}{d p} (\theta \text{ const.}) \cdot \cdot \cdot \quad (1)$$

$$\frac{d v}{d \phi} (p \text{ const.}) = \frac{d \theta}{d p} (\phi \text{ const.}) \cdot \cdot \cdot \quad (2)$$

$$\frac{d p}{d \theta} (v \text{ const.}) = \frac{d \phi}{d v} (\theta \text{ const.}) \cdot \cdot \cdot \quad (3)$$

$$\frac{d p}{d \phi} (v \text{ const.}) = - \frac{d \theta}{d v} (\phi \text{ const.}) \cdot \cdot \cdot \quad (4)$$

Here v denotes the volume,
 p ,, pressure.
 θ ,, absolute temperature.
 ϕ ,, thermodynamic function.

Figure 9.6: Maxwell's relations as first written by Maxwell, 1871.

9.4 Specific heat capacity

Recall from Eqs. (3.215, 3.218) that specific heat capacities are defined as

$$c_v = \left. \frac{\partial u}{\partial T} \right|_v, \quad (9.57)$$

$$c_P = \left. \frac{\partial h}{\partial T} \right|_P. \quad (9.58)$$

Then perform operations on the Gibbs equation, Eq. (6.59):

$$du = T ds - P dv, \quad (9.59)$$

$$\left. \frac{\partial u}{\partial T} \right|_v = T \left. \frac{\partial s}{\partial T} \right|_v, \quad (9.60)$$

$$c_v = T \left. \frac{\partial s}{\partial T} \right|_v. \quad (9.61)$$

Likewise, operating on Eq. (6.66), we get,

$$dh = T ds + v dP, \quad (9.62)$$

$$\left. \frac{\partial h}{\partial T} \right|_P = T \left. \frac{\partial s}{\partial T} \right|_P, \quad (9.63)$$

$$c_P = T \left. \frac{\partial s}{\partial T} \right|_P. \quad (9.64)$$

One finds further useful relations by operating on the Gibbs equation, Eq. (6.59):

$$du = T ds - P dv, \quad (9.65)$$

$$\left. \frac{\partial u}{\partial v} \right|_T = T \left. \frac{\partial s}{\partial v} \right|_T - P, \quad (9.66)$$

$$= T \left. \frac{\partial P}{\partial T} \right|_v - P. \quad (9.67)$$

So one can then say

$$u = u(T, v), \quad (9.68)$$

$$du = \left. \frac{\partial u}{\partial T} \right|_v dT + \left. \frac{\partial u}{\partial v} \right|_T dv, \quad (9.69)$$

$$= c_v dT + \underbrace{\left(T \left. \frac{\partial P}{\partial T} \right|_v - P \right)}_{\left. \frac{\partial u}{\partial v} \right|_T} dv. \quad (9.70)$$

For an ideal gas, one has

$$\left. \frac{\partial u}{\partial v} \right|_T = T \left. \frac{\partial P}{\partial T} \right|_v - P, \quad (9.71)$$

$$= T \left(\frac{R}{v} \right) - \frac{RT}{v}, \quad (9.72)$$

$$= 0. \quad (9.73)$$

Consequently, we have proved what was asserted in Sec. 3.8.1: u is not a function of v for an ideal gas, so $u = u(T)$ alone. Because $h = u + Pv$, h for an ideal gas reduces to $h = u + RT$. Thus,

$$h = u(T) + RT = h(T). \quad (9.74)$$

Now, return to general equations of state. With $s = s(T, v)$ or $s = s(T, P)$, one gets

$$ds = \left. \frac{\partial s}{\partial T} \right|_v dT + \left. \frac{\partial s}{\partial v} \right|_T dv, \quad (9.75)$$

$$ds = \left. \frac{\partial s}{\partial T} \right|_P dT + \left. \frac{\partial s}{\partial P} \right|_T dP. \quad (9.76)$$

Now, using Eqs. (9.41, 9.56, 9.61, 9.64) one gets

$$ds = \frac{c_v}{T} dT + \left. \frac{\partial P}{\partial T} \right|_v dv, \quad (9.77)$$

$$ds = \frac{c_P}{T} dT - \left. \frac{\partial v}{\partial T} \right|_P dP. \quad (9.78)$$

Subtracting Eq. (9.78) from Eq. (9.77), one finds

$$0 = \frac{c_v - c_P}{T} dT + \left. \frac{\partial P}{\partial T} \right|_v dv + \left. \frac{\partial v}{\partial T} \right|_P dP, \quad (9.79)$$

$$(c_P - c_v) dT = T \left. \frac{\partial P}{\partial T} \right|_v dv + T \left. \frac{\partial v}{\partial T} \right|_P dP. \quad (9.80)$$

Now, divide both sides by dT and hold *either* P or v constant. In either case, one gets

$$c_P - c_v = T \left. \frac{\partial P}{\partial T} \right|_v \left. \frac{\partial v}{\partial T} \right|_P. \quad (9.81)$$

Also, because $\left. \frac{\partial P}{\partial T} \right|_v = -(\left. \frac{\partial P}{\partial v} \right|_T)(\left. \frac{\partial v}{\partial T} \right|_P)$, Eq. (9.81) can be rewritten as

$$c_P - c_v = -T \left(\left. \frac{\partial v}{\partial T} \right|_P \right)^2 \left. \frac{\partial P}{\partial v} \right|_T. \quad (9.82)$$

Now, because $T > 0$, $(\left. \frac{\partial v}{\partial T} \right|_P)^2 > 0$, and for all known materials $\left. \frac{\partial P}{\partial v} \right|_T < 0$, we must have

$$c_P > c_v. \quad (9.83)$$

Example 9.1

For a CIIG, prove Mayer's relation, Eq. (3.234), $c_P(T) - c_v(T) = R$.

For the ideal gas, $Pv = RT$, one has

$$\left. \frac{\partial P}{\partial T} \right|_v = \frac{R}{v}, \quad \left. \frac{\partial v}{\partial T} \right|_P = \frac{R}{P}. \quad (9.84)$$

So, substituting these into Eq. (9.81), we get

$$c_P - c_v = T \frac{R}{v} \frac{R}{P}, \quad (9.85)$$

$$= T \frac{R^2}{RT}, \quad (9.86)$$

$$= R. \quad (9.87)$$

This holds even if the ideal gas is calorically imperfect. That is,

$$\boxed{c_P(T) - c_v(T) = R.} \quad Q.E.D. \quad (9.88)$$

For the ratio of specific heats for a general material, one can use Eqs. (9.61) and (9.64) to get

$$k = \frac{c_P}{c_v} = \frac{T \left. \frac{\partial s}{\partial T} \right|_P}{T \left. \frac{\partial s}{\partial T} \right|_v}, \quad \text{then apply Eq. (9.20) to get} \quad (9.89)$$

$$= \frac{\left. \frac{\partial s}{\partial T} \right|_P \left. \frac{\partial T}{\partial s} \right|_v}{\left. \frac{\partial T}{\partial s} \right|_P \left. \frac{\partial s}{\partial T} \right|_v}, \quad \text{then apply Eq. (9.22) to get} \quad (9.90)$$

$$= \left(- \left. \frac{\partial s}{\partial P} \right|_T \left. \frac{\partial P}{\partial T} \right|_s \right) \left(- \left. \frac{\partial T}{\partial v} \right|_s \left. \frac{\partial v}{\partial s} \right|_T \right), \quad (9.91)$$

$$= \left(\left. \frac{\partial v}{\partial s} \right|_T \left. \frac{\partial s}{\partial P} \right|_T \right) \left(\left. \frac{\partial P}{\partial T} \right|_s \left. \frac{\partial T}{\partial v} \right|_s \right), \quad (9.92)$$

$$= \left. \frac{\partial v}{\partial P} \right|_T \left. \frac{\partial P}{\partial v} \right|_s. \quad (9.93)$$

The first term can be obtained from $P - v - T$ data. The second term is related to the isentropic sound speed of the material, that is also a measurable quantity.

Let us see how one can use a general thermal equation of state, $P = P(v, T)$ to deduce an expression for entropy.. Because we can expect $s = s(T, P)$, we can say

$$ds = \left. \frac{\partial s}{\partial T} \right|_P dT + \left. \frac{\partial s}{\partial P} \right|_T dP. \quad (9.94)$$

Using Eq. (9.64) and the Maxwell relation of Eq. (9.56), we can rewrite as

$$ds = \frac{c_P}{T} dT - \left. \frac{\partial v}{\partial T} \right|_P dP. \quad (9.95)$$

One can integrate to find $s(T, P)$.

Similarly for $s = s(T, v)$, we can say

$$ds = \left. \frac{\partial s}{\partial T} \right|_v dT + \left. \frac{\partial s}{\partial v} \right|_T dv. \quad (9.96)$$

Using Eq. (9.61) and the Maxwell relation of Eq. (9.48), we can rewrite as

$$ds = \frac{c_v}{T} dT + \left. \frac{\partial P}{\partial T} \right|_v dv. \quad (9.97)$$

One can integrate to find $s(T, v)$.

9.5 The first law and coordinate transformations

One can apply standard notions from the mathematics of coordinate transformations to the first law of thermodynamics. Recall the primitive form of the first law Eq. (3.155):

$\oint \delta Q = \oint \delta W$. In intensive form, this becomes

$$\oint \delta q = \oint \delta w. \quad (9.98)$$

We also know that $\delta q = T ds$ and $\delta w = P dv$, so that

$$\oint T ds = \oint P dv. \quad (9.99)$$

Geometrically, one could say that an area in the $T-s$ plane has the same value in the $P-v$ plane. Moreover, because the cyclic integral is direction-dependent, one must insist that an area in the $T-s$ plane maintain its orientation in the $P-v$ plane. As an example, a rotation of a two-dimensional geometric entity preserves area and orientation, while a reflection of the same entity preserves area, but not orientation.

Now we can consider equations of state to be coordinate mappings; for example, consider the general equations of state

$$T = T(P, v), \quad (9.100)$$

$$s = s(P, v). \quad (9.101)$$

These are mappings that take points in the $P-v$ plane into the $T-s$ plane. The differentials of Eqs. (9.100,9.101) are

$$dT = \left. \frac{\partial T}{\partial P} \right|_v dP + \left. \frac{\partial T}{\partial v} \right|_P dv, \quad (9.102)$$

$$ds = \left. \frac{\partial s}{\partial P} \right|_v dP + \left. \frac{\partial s}{\partial v} \right|_P dv. \quad (9.103)$$

In matrix form, we could say

$$\begin{pmatrix} dT \\ ds \end{pmatrix} = \underbrace{\begin{pmatrix} \left. \frac{\partial T}{\partial P} \right|_v & \left. \frac{\partial T}{\partial v} \right|_P \\ \left. \frac{\partial s}{\partial P} \right|_v & \left. \frac{\partial s}{\partial v} \right|_P \end{pmatrix}}_{=\mathbf{J}} \begin{pmatrix} dP \\ dv \end{pmatrix}. \quad (9.104)$$

Here, we have defined the *Jacobian matrix* of the mapping from the standard mathematics of coordinate transformations:

$$\mathbf{J} = \begin{pmatrix} \left. \frac{\partial T}{\partial P} \right|_v & \left. \frac{\partial T}{\partial v} \right|_P \\ \left. \frac{\partial s}{\partial P} \right|_v & \left. \frac{\partial s}{\partial v} \right|_P \end{pmatrix}. \quad (9.105)$$

In a standard result from mathematics, for a coordinate transformation to be area- and orientation-preserving, its *Jacobian determinant*, J must have a value of unity:

$$J \equiv \det \mathbf{J} = \begin{vmatrix} \left. \frac{\partial T}{\partial P} \right|_v & \left. \frac{\partial T}{\partial v} \right|_P \\ \left. \frac{\partial s}{\partial P} \right|_v & \left. \frac{\partial s}{\partial v} \right|_P \end{vmatrix} = 1. \quad (9.106)$$

Expanding the Jacobian determinant, we require

$$J = \frac{\partial T}{\partial P} \Big|_v \frac{\partial s}{\partial v} \Big|_P - \frac{\partial T}{\partial v} \Big|_P \frac{\partial s}{\partial P} \Big|_v = 1. \quad (9.107)$$

For general mathematical background of Jacobian matrices and coordinate transformations, the interested reader can consult a variety of sources, for example, Kaplan,⁶ or Powers and Sen.⁷

Example 9.2

Show a CPIG has a mapping from the $T - s$ plane to the $P - v$ plane that is area- and orientation-preserving.

For a CPIG, it is easily shown, see Eq. (6.91) for $s(P, v)$, that

$$T(P, v) = \frac{Pv}{R}, \quad (9.108)$$

$$s(P, v) = s_o + c_P \ln \left(\frac{v}{v_o} \right) + c_v \ln \left(\frac{P}{P_o} \right). \quad (9.109)$$

Calculating J from Eq. (9.107), we find

$$J = \left(\frac{v}{R} \right) \left(\frac{c_P}{v} \right) - \left(\frac{P}{R} \right) \left(\frac{c_v}{P} \right), \quad (9.110)$$

$$= \frac{c_P - c_v}{R} = \frac{R}{R} = 1. \quad (9.111)$$

9.6 The van der Waals gas

A van der Waals gas is a common model for a non-ideal gas, introduced earlier in Ch. 2.4.2.1. It can capture some of the behavior of a gas as it approaches the vapor dome. Its form was first presented in Eqs. (2.46), (2.47):

$$P(T, v) = \frac{RT}{v - b} - \frac{a}{v^2}, \quad (9.112)$$

where b accounts for the finite volume of the molecules, and a accounts for intermolecular forces.

⁶W. Kaplan, 2003, *Advanced Calculus*, Fifth Edition, Addison-Wesley, Boston, pp. 90-95, pp. 331-336.

⁷J. M. Powers and M. Sen, 2015, *Mathematical Methods in Engineering*, Cambridge, New York, pp. 31-42.

If we select

$$a = \frac{27 R^2 T_c^2}{64 P_c}, \quad b = \frac{1 R T_c}{8 P_c}, \quad (9.113)$$

where T_c and P_c are the critical point temperature and pressure, respectively, we approximate some physical behavior well, namely

- at the critical point $\partial P/\partial v|_T = 0$; that is an isotherm has a zero slope in the $P - v$ plane at the critical point, and
- at the critical point $\partial^2 P/\partial v^2|_T = 0$; that is an isotherm has a point of inflection in the $P - v$ plane at the critical point.

It is also easy to show that at the critical point, we have

$$v_c = 3b = \frac{3 R T_c}{8 P_c}. \quad (9.114)$$

Example 9.3

Show an isotherm has a slope of zero in the $P - v$ plane at the critical point for a van der Waals model.

Taking a partial derivative of Eq. (9.112), we see that

$$\left. \frac{\partial P}{\partial v} \right|_T = -\frac{RT}{(v-b)^2} + \frac{2a}{v^3}. \quad (9.115)$$

At the critical point, this has value

$$\left. \frac{\partial P}{\partial v} \right|_T \Big|_{critical\ point} = -\frac{RT_c}{(v_c-b)^2} + \frac{2a}{v_c^3}. \quad (9.116)$$

Now, substitute values for a , b , and v_c for the van der Waals gas to get

$$\left. \frac{\partial P}{\partial v} \right|_T \Big|_{critical\ point} = -\frac{RT_c}{\left(\frac{3}{8} \frac{RT_c}{P_c} - \left(\frac{RT_c}{8P_c}\right)\right)^2} + \frac{2 \left(\frac{27 R^2 T_c^2}{64 P_c}\right)}{\left(\frac{3}{8} \frac{RT_c}{P_c}\right)^3}, \quad (9.117)$$

$$= -\frac{RT_c}{\left(\frac{1}{4} \frac{RT_c}{P_c}\right)^2} + \frac{RT_c \left(\frac{27}{32} \frac{RT_c}{P_c}\right)}{\left(\frac{3}{8} \frac{RT_c}{P_c}\right)^3}, \quad (9.118)$$

$$= \frac{RT_c}{\left(\frac{RT_c}{P_c}\right)^2} \left(-\frac{1}{\left(\frac{1}{4}\right)^2} + \frac{\left(\frac{27}{32}\right)}{\left(\frac{3}{8}\right)^3}\right), \quad (9.119)$$

$$= \frac{P_c^2}{RT_c} \left(-16 + \left(\frac{27}{32}\right) \left(\frac{512}{27}\right)\right) = 0. \quad (9.120)$$

One could similarly take the second derivative and show the critical point is a point of inflection.

Example 9.4

Consider the van der Waals equation for water.

For water, we have $T_c = 374.15\text{ }^\circ\text{C} = 647.3\text{ K}$ and $P_c = 22120\text{ kPa}$. We also have $M = 18.015\text{ kg/kmole}$. So

$$R = \frac{\bar{R}}{M} = \frac{8.314 \frac{\text{kJ}}{\text{kmole K}}}{18.015 \frac{\text{kg}}{\text{kmole}}} = 0.4615 \frac{\text{kJ}}{\text{kg K}}. \quad (9.121)$$

Thus, our constants are

$$a = \frac{27 \left(0.4615 \frac{\text{kJ}}{\text{kg K}}\right)^2 (647.3\text{ K})^2}{64 (22120\text{ kPa})} = 1.70201 \frac{\text{kPa m}^6}{\text{kg}^2}, \quad (9.122)$$

$$b = \frac{\left(0.4615 \frac{\text{kJ}}{\text{kg K}}\right) (647.3\text{ K})}{8(22120\text{ kPa})} = 0.00168813 \frac{\text{m}^3}{\text{kg}}. \quad (9.123)$$

So our van der Waals equation of state for water is

$$P = \frac{\left(0.4615 \frac{\text{kJ}}{\text{kg K}}\right) T}{v - \left(0.00168813 \frac{\text{m}^3}{\text{kg}}\right)} - \frac{\left(1.70201 \frac{\text{kPa m}^6}{\text{kg}^2}\right)}{v^2}. \quad (9.124)$$

Some isotherms for water, as predicted by the van der Waals equation, are given along with the actual data for the vapor dome in Fig. 9.7. Obviously, the van der Waals predictions are not valid inside the vapor dome, where isotherms must be isobars.

The *critical volume* is predicted by the van der Waals model, Eq. (9.114), to be

$$v_c = 3b = \frac{3}{8} \frac{RT_c}{P_c} = \frac{3}{8} \frac{\left(0.4615 \frac{\text{kJ}}{\text{kg K}}\right) (647.3\text{ K})}{22120\text{ kPa}} = 0.00506439 \frac{\text{m}^3}{\text{kg}}. \quad (9.125)$$

The actual data from Table B.1.2 of BS gives $v_c = 0.003155\text{ m}^3/\text{kg}$, so clearly the van der Waals equation has some inaccuracy, even near the critical point. This inaccuracy is clearly seen in Fig. 9.7 as the isotherm corresponding to $T = T_c = 647.3\text{ K}$ has its zero-slope inflection point at $P = P_c = 22120\text{ kPa}$, slightly displaced from the measured value of v_c .

Example 9.5

Find a general expression for the caloric equation of state for $u(T, v)$ if we have a van der Waals gas thermal equation of state.

$$P(T, v) = \frac{RT}{v - b} - \frac{a}{v^2}. \quad (9.126)$$

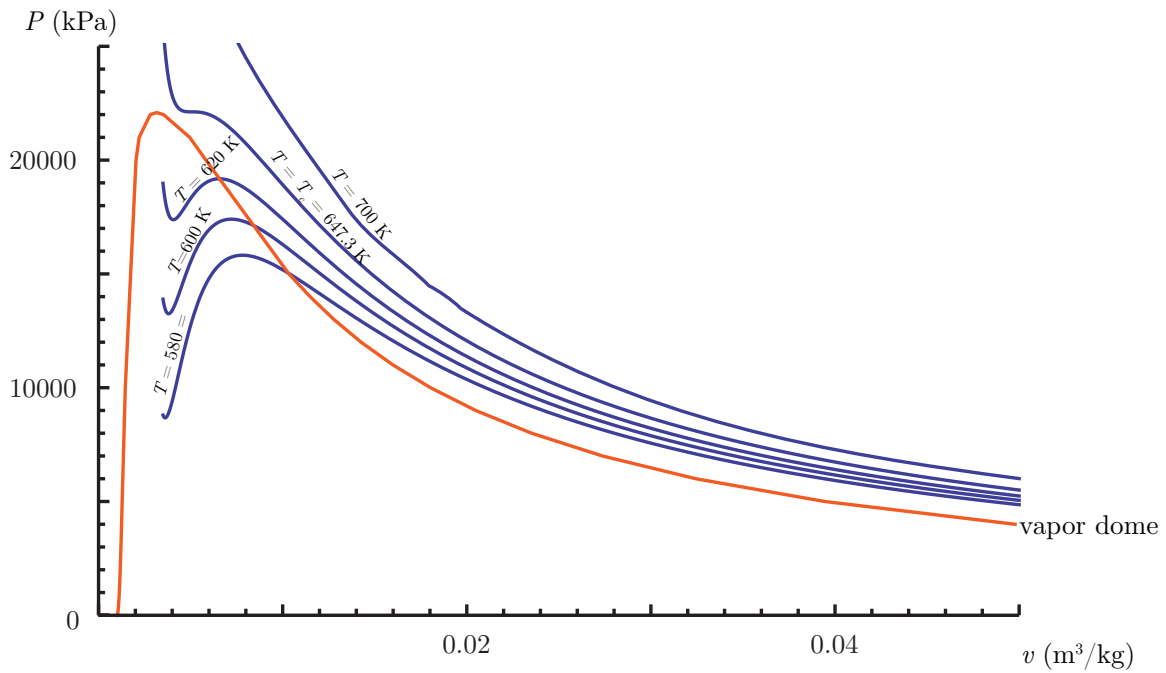

Figure 9.7: Isotherms for water as predicted by the van der Waals equation along with actual data for the vapor dome.

Proceed as before: First because $u = u(T, v)$ we have Eq. (9.70):

$$du = \left. \frac{\partial u}{\partial T} \right|_v dT + \left. \frac{\partial u}{\partial v} \right|_T dv. \quad (9.127)$$

Recalling Eqs. (3.214), (9.67), we also have that

$$\left. \frac{\partial u}{\partial T} \right|_v = c_v, \quad \left. \frac{\partial u}{\partial v} \right|_T = T \left. \frac{\partial P}{\partial T} \right|_v - P. \quad (9.128)$$

Now, for the van der Waals gas, we find

$$\left. \frac{\partial P}{\partial T} \right|_v = \frac{R}{v-b}, \quad (9.129)$$

$$T \left. \frac{\partial P}{\partial T} \right|_v - P = \frac{RT}{v-b} - P, \quad (9.130)$$

$$= \frac{RT}{v-b} - \underbrace{\left(\frac{RT}{v-b} - \frac{a}{v^2} \right)}_P, \quad (9.131)$$

$$= \frac{a}{v^2}. \quad (9.132)$$

So we have

$$\left. \frac{\partial u}{\partial v} \right|_T = \frac{a}{v^2}, \quad (9.133)$$

$$u(T, v) = -\frac{a}{v} + f(T). \quad (9.134)$$

Here, $f(T)$ is some as-of-yet arbitrary function of T . To evaluate $f(T)$, take the derivative with respect to T holding v constant:

$$\left. \frac{\partial u}{\partial T} \right|_v = \frac{df}{dT} = c_v. \quad (9.135)$$

Because f is a function of T at most, here c_v can be a function of T at most, so we allow $c_v = c_v(T)$. Integrating, we find $f(T)$ as

$$f(T) = C + \int_{T_o}^T c_v(\hat{T}) d\hat{T}, \quad (9.136)$$

where C is an integration constant. Thus, u is

$$u(T, v) = C + \int_{T_o}^T c_v(\hat{T}) d\hat{T} - \frac{a}{v}. \quad (9.137)$$

Taking $C = u_o + a/v_o$, we get

$$\boxed{u(T, v) = u_o + \int_{T_o}^T c_v(\hat{T}) d\hat{T} + a \left(\frac{1}{v_o} - \frac{1}{v} \right)}. \quad (9.138)$$

We also find

$$h = u + Pv = u_o + \int_{T_o}^T c_v(\hat{T}) d\hat{T} + a \left(\frac{1}{v_o} - \frac{1}{v} \right) + Pv, \quad (9.139)$$

$$h(T, v) = u_o + \int_{T_o}^T c_v(\hat{T}) d\hat{T} + a \left(\frac{1}{v_o} - \frac{1}{v} \right) + \frac{RTv}{v-b} - \frac{a}{v}. \quad (9.140)$$

Example 9.6

Consider an isothermal compression of water at $T = 400^\circ\text{C}$ from $P_1 = 8000$ kPa to $P_2 = 10000$ kPa. Analyze this using a van der Waals gas model. Compare some results to those from an ideal gas model and those from a steam table model.

At state 1, we have $T_1 = 400^\circ\text{C} = 673.15$ K. Note that $T_1 > T_c$. Now, we also have $P_1 = 8000$ kPa. Note that $P_1 < P_c$. Let us find an estimate for v_1 from the van der Waals equation, Eq. (9.124):

$$P_1 = 8000 \text{ kPa} = \frac{\left(0.4615 \frac{\text{kJ}}{\text{kg K}}\right) (673.15 \text{ K})}{v_1 - \left(0.00168813 \frac{\text{m}^3}{\text{kg}}\right)} - \frac{\left(1.70201 \frac{\text{kPa m}^6}{\text{kg}^2}\right)}{v_1^2}. \quad (9.141)$$

Omitting units, Eq. (9.141) expands to $-3.59151 \times 10^{-7} + 0.000212751v_1 - 0.0405208v_1^2 + v_1^3 = 0$. This cubic equation has three roots:

$$v_1 = 0.00291758 \pm 0.00135727i \frac{\text{m}^3}{\text{kg}}, \quad \text{non-physical}, \quad (9.142)$$

$$v_1 = 0.0346857 \frac{\text{m}^3}{\text{kg}}, \quad \text{physical}. \quad (9.143)$$

The two non-physical roots are a complex conjugate pair. In other cases, they might appear to be physical, but will still be nothing more than mathematical relics with no physical meaning. At this state, the ideal gas law, $v_1 = RT_1/P_1$ predicts a value of $v_{1,ideal\ gas} = 0.0388327 \text{ m}^3/\text{kg}$. Data from the steam tables show that $v_{1,steam\ tables} = 0.03432 \text{ m}^3/\text{kg}$. So the van der Waals equation gives a better prediction of v_1 than does an ideal gas assumption.

At state 2, we have $T_2 = 400 \text{ }^\circ\text{C} = 673.15 \text{ K}$ and $P_2 = 10000 \text{ kPa}$. Again, we find an estimate for v_2 from the van der Waals equation, Eq. (9.124):

$$P_2 = 10000 \text{ kPa} = \frac{\left(0.4615 \frac{\text{kJ}}{\text{kg K}}\right) (673.15 \text{ K})}{v_2 - \left(0.00168813 \frac{\text{m}^3}{\text{kg}}\right)} - \frac{\left(1.70201 \frac{\text{kPa m}^6}{\text{kg}^2}\right)}{v_2^2}. \quad (9.144)$$

Again, we find three roots:

$$v_2 = 0.0029749 \pm 0.00136715i \frac{\text{m}^3}{\text{kg}}, \quad \text{non-physical}, \quad (9.145)$$

$$v_2 = 0.0268045 \frac{\text{m}^3}{\text{kg}}, \quad \text{physical}. \quad (9.146)$$

At this state, the ideal gas law, $v_2 = RT_2/P_2$ predicts a value of $v_{2,ideal\ gas} = 0.0310662 \text{ m}^3/\text{kg}$. Data from the steam tables show that $v_{2,steam\ tables} = 0.02641 \text{ m}^3/\text{kg}$. So again, the van der Waals equation gives a better prediction of v_2 than does an ideal gas assumption.

The first law of thermodynamics tells us

$$u_2 - u_1 = {}_1q_2 - {}_1w_2. \quad (9.147)$$

Because we can compute $u_2 - u_1$ and ${}_1w_2$, the first law lets us get the heat transfer ${}_1q_2$. Let us first compute the work:

$${}_1w_2 = \int_1^2 P dv, \quad (9.148)$$

$$= \int_1^2 \left(\frac{RT}{v-b} - \frac{a}{v^2} \right) dv, \quad (9.149)$$

$$= RT_1 \ln \frac{v_2 - b}{v_1 - b} + a \left(\frac{1}{v_2} - \frac{1}{v_1} \right), \quad (9.150)$$

$$= \left(0.461504 \frac{\text{kJ}}{\text{kg K}} \right) (673.15 \text{ K}) \ln \frac{\left(0.0268045 \frac{\text{m}^3}{\text{kg}} \right) - \left(0.00168813 \frac{\text{m}^3}{\text{kg}} \right)}{\left(0.0346857 \frac{\text{m}^3}{\text{kg}} \right) - \left(0.00168813 \frac{\text{m}^3}{\text{kg}} \right)} + \left(1.70201 \frac{\text{kPa m}^6}{\text{kg}^2} \right) \left(\frac{1}{0.0268045 \frac{\text{m}^3}{\text{kg}}} - \frac{1}{0.0346857 \frac{\text{m}^3}{\text{kg}}} \right), \quad (9.151)$$

$$= -70.3563 \frac{\text{kJ}}{\text{kg}}. \quad (9.152)$$

The work in compression is negative. From the steam tables, we could estimate the work via numerical integration along an isotherm. We only have two data points from the steam tables, so the estimate is simple ${}_1w_2 \sim P_{ave}(v_2 - v_1)$. This gives $(9000 \text{ kPa})(0.02641 \text{ m}^3/\text{kg} - 0.03432 \text{ m}^3/\text{kg}) = -71.19 \text{ kJ/kg}$.

Now, let us find $u_2 - u_1$. Note if we had an ideal gas, this would be zero, because it is an isothermal process. However, the van der Waals gas has $u(T, v)$, and because v changes, so does u . From Eq. (9.138), we can deduce that

$$u_2 - u_1 = \underbrace{\int_{T_1}^{T_2} c_v(T) dT}_{=0} - a \left(\frac{1}{v_2} - \frac{1}{v_1} \right), \quad (9.153)$$

$$= - \left(1.70201 \frac{\text{kPa m}^6}{\text{kg}^2} \right) \left(\frac{1}{0.0268045 \frac{\text{m}^3}{\text{kg}}} - \frac{1}{0.0346857 \frac{\text{m}^3}{\text{kg}}} \right), \quad (9.154)$$

$$= -14.4277 \frac{\text{kJ}}{\text{kg}}. \quad (9.155)$$

We can compare this with $u_2 - u_1$ from the steam tables, that gives $(2832.38 \text{ kJ/kg}) - (2863.75 \text{ kJ/kg}) = -31.37 \text{ kJ/kg}$.

So the heat transfer is

$${}_1q_2 = u_2 - u_1 + {}_1w_2, \quad (9.156)$$

$$= \left(-14.4277 \frac{\text{kJ}}{\text{kg}} \right) + \left(-70.3563 \frac{\text{kJ}}{\text{kg}} \right), \quad (9.157)$$

$$= -84.7839 \frac{\text{kJ}}{\text{kg}}. \quad (9.158)$$

This compares with an estimate based on the steam tables of ${}_1q_2 = -102.56 \text{ kJ/kg}$.

Now, let us get the entropy change. We start with the Gibbs equation, Eq. (6.59): $du = T ds - P dv$. Rearranging, we get

$$T ds = du + P dv. \quad (9.159)$$

We can differentiate Eq. (9.138) to get

$$du = c_v(T) dT + \frac{a}{v^2} dv. \quad (9.160)$$

Substitute Eq. (9.160) into Eq. (9.159) to get

$$T ds = c_v(T) dT + \left(P + \frac{a}{v^2} \right) dv. \quad (9.161)$$

Now, we know from the van der Waals gas equation, Eq. (9.112), that $P + a/v^2 = (RT)/(v - b)$, so Eq. (9.161) reduces to

$$T ds = c_v(T) dT + \frac{RT}{v - b} dv, \quad (9.162)$$

$$ds = \frac{c_v(T)}{T} dT + \frac{R}{v - b} dv, \quad (9.163)$$

$$s_2 - s_1 = \int_1^2 \frac{c_v(T)}{T} dT + R \ln \frac{v_2 - b}{v_1 - b}. \quad (9.164)$$

For the isothermal changes of this problem, we have simply

$$s_2 - s_1 = R \ln \frac{v_2 - b}{v_1 - b}, \quad (9.165)$$

$$= \left(0.461504 \frac{\text{kJ}}{\text{kg K}} \right) \ln \frac{\left(0.0268045 \frac{\text{m}^3}{\text{kg}} \right) - \left(0.00168813 \frac{\text{m}^3}{\text{kg}} \right)}{\left(0.0346857 \frac{\text{m}^3}{\text{kg}} \right) - \left(0.00168813 \frac{\text{m}^3}{\text{kg}} \right)}, \quad (9.166)$$

$$= -0.12591 \frac{\text{kJ}}{\text{kg K}}. \quad (9.167)$$

The estimate of the entropy change from the steam tables is $s_2 - s_1 = 6.2119 \text{ kJ/kg/K} - 6.3633 \text{ kJ/kg/K} = -0.1514 \text{ kJ/kg/K}$.

Note that for this isothermal problem

$$s_2 - s_1 = \int_1^2 \frac{\delta q}{T} = \frac{1q_2}{T} = \frac{-84.7839 \frac{\text{kJ}}{\text{kg}}}{673.15 \text{ K}} = -0.125951 \frac{\text{kJ}}{\text{kg K}}. \quad (9.168)$$

Thermal energy left the system, and its entropy went down. This thermal energy entered the surroundings, that needed to have $T_{surr} \leq 673.15 \text{ K}$ for this process to occur. Had $T_{surr} = 673.15 \text{ K}$, the heat transfer process would have been slow, and the entropy of the surroundings would have risen by precisely enough to balance the loss in the system, keeping the entropy of the universe constant. The lower the surroundings' temperature, the higher the total entropy change of the universe would have been.

Example 9.7

Use Eq. (9.97) as an alternative way to find the entropy of a van der Waals gas.

We start with Eq. (9.97):

$$ds = \frac{c_v}{T} dT + \left. \frac{\partial P}{\partial T} \right|_v dv. \quad (9.169)$$

From Eq. (9.135) we know for a van der Waals gas that at most $c_v = c_v(T)$. And for this material, we also have $\partial P / \partial T|_v = R / (v - b)$. So we get

$$ds = \frac{c_v(T)}{T} dT + \frac{R}{v - b} dv. \quad (9.170)$$

Integrating, we get

$$s(T, v) = s_o + \int_{T_o}^T \frac{c_v(\hat{T})}{\hat{T}} + R \ln \frac{v - b}{v_o - b}. \quad (9.171)$$

This is equivalent to what we found in Eq. (9.164).

Example 9.8

Find $c_P - c_v$ for a van der Waals gas.

We start with Eq. (9.81):

$$c_P - c_v = T \left. \frac{\partial P}{\partial T} \right|_v \left. \frac{\partial v}{\partial T} \right|_P. \quad (9.172)$$

Now, $\partial v / \partial T|_P$ is difficult to compute for a van der Waals gas. But its reciprocal is not. Therefore let us seek

$$c_P - c_v = T \frac{\left. \frac{\partial P}{\partial T} \right|_v}{\left. \frac{\partial v}{\partial T} \right|_P}. \quad (9.173)$$

Now, for the van der Waals gas, Eq. (2.46), we have

$$P = \frac{RT}{v-b} - \frac{a}{v^2}, \quad (9.174)$$

and we easily get

$$\left. \frac{\partial P}{\partial T} \right|_v = \frac{R}{v-b}. \quad (9.175)$$

We also solve for T to get

$$T = \frac{(v-b)(a + Pv^2)}{Rv^2}. \quad (9.176)$$

Leaving out details, one can show that

$$\left. \frac{\partial T}{\partial v} \right|_P = \frac{Pv^3 - av + 2ab}{Rv^3}. \quad (9.177)$$

Eliminating P , one can then show, leaving out details, that

$$\left. \frac{\partial T}{\partial v} \right|_P = \frac{RTv^3 - 2ab^2 + 4abv - 2av^2}{Rv^3(v-b)}. \quad (9.178)$$

Substituting for $c_P - c_v$, it is seen, omitting many algebraic details, that

$$\boxed{c_P - c_v = R \left(\frac{1}{1 - \frac{2a(v-b)^2}{RTv^3}} \right)}. \quad (9.179)$$

Thus, Mayer's relation, Eq. (3.234), does not hold for the van der Waals gas. Note that when $a = 0$, Mayer's relation again holds, even for $b \neq 0$.

9.7 Adiabatic sound speed

With help from the mass, linear momentum, and energy equations, along with validation from experiment, it can be shown that the speed of sound waves, c , is given by the formula

$$c = \sqrt{\left. \frac{\partial P}{\partial \rho} \right|_s}. \quad (9.180)$$

As the entropy is constant for such a calculation, this is sometimes called the adiabatic sound speed.

Let us calculate c . From the Gibbs equation, Eq. (6.60), we have

$$T ds = du + P dv. \quad (9.181)$$

Now, because $v = 1/\rho$, we get $dv = -(1/\rho^2) d\rho$, and Eq. (9.181) can be rewritten as

$$T ds = du - \frac{P}{\rho^2} d\rho. \quad (9.182)$$

Now, for simple compressible substances, we can always form $u = u(P, \rho)$. Thus, we also have

$$du = \left. \frac{\partial u}{\partial P} \right|_{\rho} dP + \left. \frac{\partial u}{\partial \rho} \right|_P d\rho. \quad (9.183)$$

Now, use Eq. (9.183) to eliminate du in Eq. (9.182) so to get

$$T ds = \underbrace{\left. \frac{\partial u}{\partial P} \right|_{\rho} dP + \left. \frac{\partial u}{\partial \rho} \right|_P d\rho}_{=du} - \frac{P}{\rho^2} d\rho, \quad (9.184)$$

$$= \left. \frac{\partial u}{\partial P} \right|_{\rho} dP + \left(\left. \frac{\partial u}{\partial \rho} \right|_P - \frac{P}{\rho^2} \right) d\rho. \quad (9.185)$$

Now, to find $c = \sqrt{\left. \partial P / \partial \rho \right|_s}$, take $ds = 0$, divide both sides by $d\rho$, and solve for $\left. \partial P / \partial \rho \right|_s$ in Eq. (9.185) so as to get

$$\left. \frac{\partial P}{\partial \rho} \right|_s = \frac{-\left. \frac{\partial u}{\partial \rho} \right|_P + \frac{P}{\rho^2}}{\left. \frac{\partial u}{\partial P} \right|_{\rho}}. \quad (9.186)$$

Now, Eq. (9.186) is valid for a general equation of state. Let us specialize it for a CPG. For

the CPIG, we have

$$u = c_v T + \text{constant}, \quad (9.187)$$

$$= c_v \left(\frac{P}{\rho R} \right) + \text{constant}, \quad (9.188)$$

$$= \frac{c_v}{c_P - c_v} \frac{P}{\rho} + \text{constant}, \quad (9.189)$$

$$= \frac{1}{\frac{c_P}{c_v} - 1} \frac{P}{\rho} + \text{constant}, \quad (9.190)$$

$$= \frac{1}{k - 1} \frac{P}{\rho} + \text{constant}. \quad (9.191)$$

Thus, we have for the CPIG

$$\left. \frac{\partial u}{\partial P} \right|_{\rho} = \frac{1}{k - 1} \frac{1}{\rho}, \quad (9.192)$$

$$\left. \frac{\partial u}{\partial \rho} \right|_P = \frac{-1}{k - 1} \frac{P}{\rho^2}. \quad (9.193)$$

Now, substitute Eqs. (9.192, 9.193) into Eq. (9.186) to get

$$\left. \frac{\partial P}{\partial \rho} \right|_s = \frac{\frac{1}{k-1} \frac{P}{\rho^2} + \frac{P}{\rho^2}}{\frac{1}{k-1} \frac{1}{\rho}}, \quad (9.194)$$

$$= \frac{P}{\rho} + (k - 1) \frac{P}{\rho}, \quad (9.195)$$

$$= k \frac{P}{\rho}, \quad (9.196)$$

$$= kRT. \quad (9.197)$$

Thus,

$$c^2 = \left. \frac{\partial P}{\partial \rho} \right|_s = kRT, \quad (9.198)$$

$$\boxed{c = \sqrt{kRT} = \sqrt{k \frac{P}{\rho}}}. \quad (9.199)$$

Compare this to the isothermal sound speed:

$$c_T = \sqrt{\left. \frac{\partial P}{\partial \rho} \right|_T} = \sqrt{RT}. \quad (9.200)$$

By use of the ideal gas law, one can also say

$$c_T = \sqrt{\frac{P}{\rho}}. \quad (9.201)$$

This is the form Newton used in 1687 to estimate the sound speed; however, he probably used an approach different from assuming Boyle's law and taking derivatives. Newton's approach was corrected by Laplace in 1816 who generated what amounts to our adiabatic prediction, long before notions of thermodynamics were settled. Laplace is depicted in Fig. 9.8. Laplace's



Figure 9.8: Pierre-Simon Laplace (1749-1827), French mathematician and physicist who improved Newton's sound speed estimates; image from <http://mathshistory.st-andrews.ac.uk/Biographies/Laplace.html>.

notions rested on an uncertain theoretical foundation; he in fact adjusted his theory often, and it was not until thermodynamics was well established several decades later that our understanding of sound waves clarified. The interested reader can consult Finn.⁸

Example 9.9

At $T = 300$ K, estimate the adiabatic sound speed and compare it to the isothermal sound speed.

The adiabatic sound speed is

$$c = \sqrt{kRT} = \sqrt{\left(\frac{7}{5}\right) \left(287 \frac{\text{J}}{\text{kg K}}\right) (300 \text{ K})} = \boxed{347 \frac{\text{m}}{\text{s}}}. \quad (9.202)$$

The isothermal sound speed is

$$c_T = \sqrt{RT} = \sqrt{\left(287 \frac{\text{J}}{\text{kg K}}\right) (300 \text{ K})} = \boxed{293 \frac{\text{m}}{\text{s}}}. \quad (9.203)$$

Newton's published estimate in the first edition of his *Principia* was 968 ft/s = 295 m/s. In his second edition, he adjusted his estimate to 979 ft/s = 298 m/s. However, it was well known at that

⁸B. S. Finn, 1964, "Laplace and the speed of sound," *Isis*, 55(1): 7-19.

time that the measured speed of sound in air was roughly 1100 ft/s = 335 m/s. Newton put forth some speculations to try to come to agreement with experiment, but these did not stand the test of time. Careful experiment with the local temperature carefully monitored shows conclusively that the adiabatic sound speed better predicts the data observed in nature than the isothermal sound speed.

Lastly, we recall Eq. (9.93), valid for general materials, $k = (\partial v / \partial P|_T)(\partial P / \partial v|_s)$. This actually allows us to relate adiabatic and isothermal sound speeds for general materials. Slightly rearranging Eq. (9.93) and using $\rho = 1/v$, we get

$$k = \frac{\left. \frac{\partial P}{\partial v} \right|_s}{\left. \frac{\partial P}{\partial v} \right|_T} = \frac{\frac{d\rho}{dv} \left. \frac{\partial P}{\partial \rho} \right|_s}{\frac{d\rho}{dv} \left. \frac{\partial P}{\partial \rho} \right|_T} = \frac{-\frac{1}{v^2} \left. \frac{\partial P}{\partial \rho} \right|_s}{-\frac{1}{v^2} \left. \frac{\partial P}{\partial \rho} \right|_T} = \frac{\left. \frac{\partial P}{\partial \rho} \right|_s}{\left. \frac{\partial P}{\partial \rho} \right|_T} = \left(\frac{c}{c_T} \right)^2. \quad (9.204)$$

That is to say, the ratio of specific heats k is also the ratio of the square of the ratio of the adiabatic and isothermal sound speeds.

Example 9.10

Estimate the adiabatic and isothermal sound speeds of H₂O at $P_1 = 100$ kPa, $T_1 = 200$ °C.

We will need to use the steam tables to get appropriate finite difference approximations to the two relevant derivatives. The tables do not have ρ , but do have v , so let us recast the adiabatic sound speed in terms of v :

$$c^2 = \left. \frac{\partial P}{\partial \rho} \right|_s, \quad (9.205)$$

$$= \left. \frac{dv}{d\rho} \frac{\partial P}{\partial v} \right|_s, \quad (9.206)$$

$$= \left. \frac{1}{\frac{d\rho}{dv}} \frac{\partial P}{\partial v} \right|_s, \quad (9.207)$$

$$= \left. \frac{1}{-1/v^2} \frac{\partial P}{\partial v} \right|_s, \quad (9.208)$$

$$= -v^2 \left. \frac{\partial P}{\partial v} \right|_s, \quad (9.209)$$

$$c = v \sqrt{- \left. \frac{\partial P}{\partial v} \right|_s}. \quad (9.210)$$

Similarly it is easy to show that

$$c_T = v \sqrt{- \left. \frac{\partial P}{\partial v} \right|_T}. \quad (9.211)$$

Now the steam tables tell us at the given state that

$$v_1 = 2.17226 \frac{\text{m}^3}{\text{kg}}, \quad s_1 = 7.8342 \frac{\text{kJ}}{\text{kg K}}. \quad (9.212)$$

Let us now perturb the pressure, holding entropy constant, to a nearby pressure for which data is available. Let us take then $P_2 = 200$ kPa. We then take $s_2 = s_1 = 7.8342$ kJ/kg/K and interpolate to get

$$v_2 = 1.27893 \frac{\text{m}^3}{\text{kg}}. \quad (9.213)$$

We then estimate the adiabatic sound speed with a finite difference, taking care to convert the pressures to Pa,

$$c \approx v_1 \sqrt{-\frac{\Delta P}{\Delta v}}, \quad (9.214)$$

$$\approx v_1 \sqrt{-\frac{P_2 - P_1}{v_2 - v_1}}, \quad (9.215)$$

$$\approx \left(2.17226 \frac{\text{m}^3}{\text{kg}}\right) \sqrt{-\frac{(200000 \text{ Pa}) - (100000 \text{ Pa})}{\left(1.27893 \frac{\text{m}^3}{\text{kg}}\right) - \left(2.17226 \frac{\text{m}^3}{\text{kg}}\right)}}, \quad (9.216)$$

$$\approx \boxed{726.785 \frac{\text{m}}{\text{s}}}. \quad (9.217)$$

The isothermal sound speed requires no interpolation. For $P_2 = 200$ kPa, $T_2 = T_1 = 200$ °C, the tables tell us

$$v_2 = 1.08034 \frac{\text{m}^3}{\text{kg}}. \quad (9.218)$$

Then we get

$$c_T \approx v_1 \sqrt{-\frac{\Delta P}{\Delta v}}, \quad (9.219)$$

$$\approx v_1 \sqrt{-\frac{P_2 - P_1}{v_2 - v_1}}, \quad (9.220)$$

$$\approx \left(2.17226 \frac{\text{m}^3}{\text{kg}}\right) \sqrt{-\frac{(200000 \text{ Pa}) - (100000 \text{ Pa})}{\left(1.08034 \frac{\text{m}^3}{\text{kg}}\right) - \left(2.17226 \frac{\text{m}^3}{\text{kg}}\right)}}, \quad (9.221)$$

$$\approx \boxed{657.38 \frac{\text{m}}{\text{s}}}. \quad (9.222)$$

We can compare these to over-simplistic estimates from approximating steam as an ideal gas with $R = 461.5$ J/kg/K and $k = 1.327$ that gives us

$$c \approx \sqrt{kRT} = \sqrt{1.327 \left(461.5 \frac{\text{kJ}}{\text{kg K}}\right) ((200 + 273.15) \text{ K})} = 538.295 \frac{\text{m}}{\text{s}}, \quad (9.223)$$

$$c_T \approx \sqrt{RT} = \sqrt{\left(461.5 \frac{\text{kJ}}{\text{kg K}}\right) ((200 + 273.15) \text{ K})} = 467.289 \frac{\text{m}}{\text{s}}. \quad (9.224)$$

The estimates from ideal gas theory are somewhat low relative to those from the tables.

We close this section with the relevant passage from a translation of Newton's *Principia*.⁹ The title page and a portion of the original 1687 Latin text are depicted in Fig. 9.9. Note the 1687 Latin text employs a slightly different numbering system for the “Problem” than does the translation.

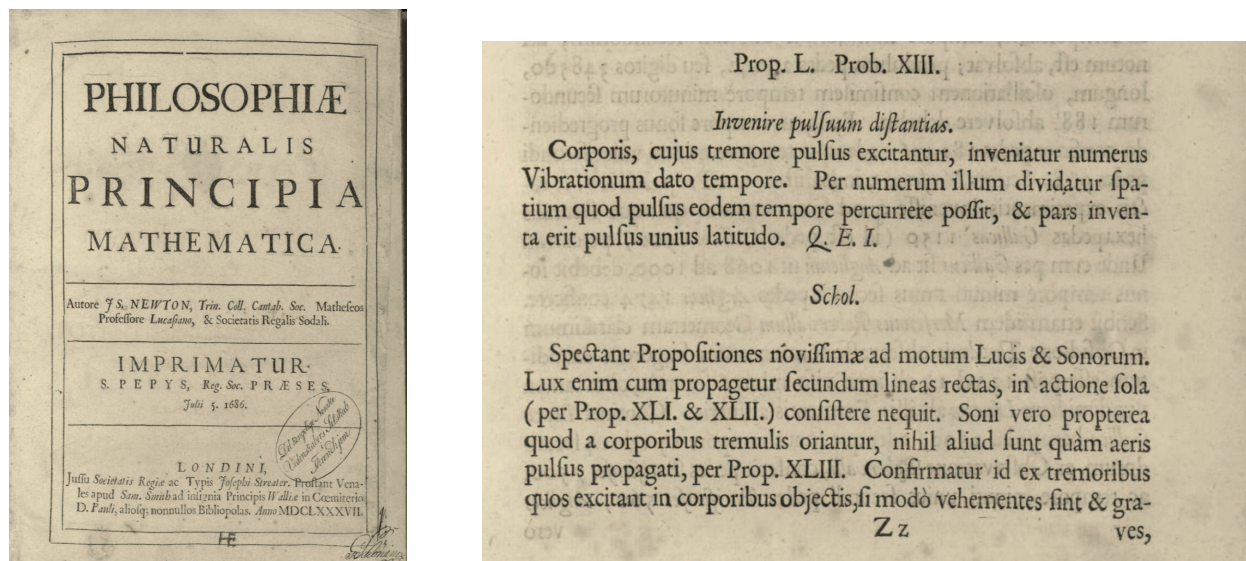

Figure 9.9: Images from the original 1687 edition of Newton's *Principia*.

PROPOSITION L. PROBLEM XII

To find the distances of the pulses

Let the number of the vibrations of the body, by whose tremor the pulses are produced, be found to any given time. By that number divide the space which a pulse can go over in the same time, and the part found will be the breadth of one pulse. Q.E.I.

SCHOLIUM

The last Propositions respect the motions of light and sounds; for since light is propagated in right lines, it is certain that it cannot consist in action alone (by Prop. XLI and XLII). As to sounds, since they arise from tremulous bodies, they can be nothing else but pulses of the air propagated through it (by Prop. XLIII); and this is confirmed by the tremors which sounds, if they be loud and

⁹I. Newton, 1934, *Principia*, Cajori's revised translation of Motte's 1729 translation, U. California Press, Berkeley. Link to the 1726 edition in the original Latin.

deep, excite in the bodies near them, as we experience in the sound of drums; for quick and short tremors are less easily excited. But it is well known that any sounds, falling upon strings in unison with the sonorous bodies, excite tremors in those strings. This is also confirmed from the velocity of sounds; for since the specific gravities of rain-water and quicksilver are to one another as about 1 to $13\frac{2}{3}$, and when the mercury in the barometer is at the height of 30 inches of our measure, the specific gravities of the air and of rain-water are to one another as about 1 to 870, therefore the specific gravities of air and quicksilver are to each other as 1 to 11890. Therefore when the height of the quicksilver is at 30 inches, a height of uniform air, whose weight would be sufficient to compress our air to the density we find it to be of, must be equal to 356700 inches, or 29725 feet of our measure; and this is that very height of the medium, which I have called A in the construction of the foregoing Proposition. A circle whose radius is 29725 feet is 186768 feet in circumference. And since a pendulum $39\frac{1}{5}$ inches in length completes one oscillation, composed of its going and return, in two seconds of time, as is commonly known, it follows that a pendulum 29725 feet, or 256700 inches in length will perform a like oscillation in $190\frac{3}{4}$ seconds. Therefore in that time a sound will go right onwards 186768 feet, and therefore in one second 979 feet.

But in this computation we have made no allowance for the crassitude of the solid particles of the air, by which the sound is propagated instantaneously. Because the weight of air is to the weight of water as 1 to 870, and because salts are almost twice as dense as water; if the particles of air are supposed to be of about the same density as those of water or salt, and the rarity of the air arises from the intervals of the particles; the diameter of one particle of air will be to the interval between the centres of the particles as 1 to about 9 or 10, and to the interval between the particles themselves as 1 to 8 or 9. Therefore to 979 feet, which according to the above calculation, a sound will advance forwards in one second of time, we may add $\frac{979}{9}$, or about 109 feet, to compensate for the crassitude of the particles of air: and then a sound will go forwards about 1088 feet in one second of time.

Moreover, the vapors floating in the air being of another spring, and a different tone, will hardly, if at all, partake of the motion of the true air in which the sounds are propagated. Now, if these vapors remain unmoved, that motion will be propagated the swifter through the true air alone, and that as the square root of the defect of the matter. So if the atmosphere consist of ten parts of true air and one part of vapors, the motion of sounds will be swifter as the square root of the ratio of 11 to 10, or very nearly in the entire ratio of 21 to 20, than if it were propagated through eleven parts of true air: and therefore the motion of sounds above discovered must be increased in that ratio. By this means the sound will pass through 1142 feet in one second of time.

These things will be found true in spring and autumn, when the air is rarefied by

the gentle warmth of those seasons, and by that means its elastic force becomes somewhat more intense. But in winter, when the air is condensed by the cold, and its elastic force is somewhat more remitted, the motion of sounds will be slower as the square root of the density; and, on the other hand, swifter in the summer.

Now, by experiments it actually appears that sounds do really advance in one second of time about 1142 feet of English measure, or 1070 feet of French measure.

The velocity of sounds being known, the intervals of the pulses are known also. For M. Sauveur, by some experiments that he made, found that an open pipe about five Paris feet in length gives a sound of the same tone with a viol sting that vibrates a hundred times in one second. therefore there are near 100 pulses in a space of 1070 Paris feet, which a sound runs over in a second of time; and therefore one pulse fills up a space of about $10 \frac{7}{10}$ Paris feet, that is, about twice the length of the pipe. From this it is probably that the breadths of the pulses, in all sounds made in open pipes, are equal to twice the length of the pipes.

Moreover, from the Corollary of Prop. XLVII appears the reason why the sounds immediately cease with the motion of the sonorous body, and why they are heard no longer when we are at a great distance from the sonorous bodies that when we are very near them. And besides, from the foregoing principles, it plainly appears how it comes to pass that sounds are so mightily increased in speaking-trumpets; for all reciprocal motion tends to be increased by the generating cause at each return. And in tubes hindering the dilatation of the sounds, the motion decays more slowly, and recurs more forcibly; and therefore is the more increased by the new motion impressed at each return. And these are the principal phenomena of sounds.

9.8 Introduction to compressible flow

We close these course notes with an opening to later coursework in which thermodynamics and the adiabatic sound speed plays a critical role: compressible fluid mechanics. We only sketch a few critical results here and leave the details for another semester.

To see the importance of the sound speed for compressible flows, let us consider briefly the equations of motion for a one-dimensional flow in a duct with area change. We ignore effects of momentum and energy diffusion as embodied in viscosity and heat conduction.

The conservation laws of mass, linear momentum, and energy can be shown to be

$$\frac{\partial}{\partial t}(\rho A) + \frac{\partial}{\partial x}(\rho v A) = 0, \quad (9.225)$$

$$\rho \left(\frac{\partial v}{\partial t} + v \frac{\partial v}{\partial x} \right) = -\frac{\partial P}{\partial x}, \quad (9.226)$$

$$\left(\frac{\partial u}{\partial t} + v \frac{\partial u}{\partial x} \right) = -P \left(\frac{\partial v}{\partial t} + v \frac{\partial v}{\partial x} \right). \quad (9.227)$$

Note, we have not specified any equation of state. It can be shown that viscosity and heat diffusion, that we have neglected, are the only mechanisms to generate entropy in a flow without shock waves. Because we have neglected these mechanisms, our equations are isentropic as long as there are no shock waves. Note that Eq. (9.227) can be rewritten as $du/dt = -P dv/dt$ when we define the material derivative as $d/dt = \partial/\partial t + v\partial/\partial x$. Thus, Eq. (9.227) also says $du = -P dv$. Comparing this to the Gibbs equation, Eq. (6.59), $du = T ds - P dv$, we see that our energy equation, Eq. (9.227), is isentropic, $ds = 0$. We can thus replace Eq. (9.227) by $ds/dt = \partial s/\partial t + v\partial s/\partial x = 0$. We also take a general equation of state $P = P(\rho, s)$. So our governing equations, Eqs. (9.225-9.227) supplemented by the general equation of state become

$$\frac{\partial}{\partial t}(\rho A) + \frac{\partial}{\partial x}(\rho v A) = 0, \quad (9.228)$$

$$\rho \left(\frac{\partial v}{\partial t} + v \frac{\partial v}{\partial x} \right) = -\frac{\partial P}{\partial x}, \quad (9.229)$$

$$\frac{\partial s}{\partial t} + v \frac{\partial s}{\partial x} = 0, \quad (9.230)$$

$$P = P(\rho, s). \quad (9.231)$$

9.8.1 Acoustics

Let us first explore the acoustic limit in which disturbances to an otherwise stationary material are small but non-zero. We restrict attention to purely isentropic flows, so $s = \text{constant}$, and all its derivatives are zero. We first consider the state equation, Eq. (9.231) so as to remove P from our analysis.

$$dP = \left. \frac{\partial P}{\partial \rho} \right|_s d\rho + \left. \frac{\partial P}{\partial s} \right|_\rho ds, \quad (9.232)$$

$$\frac{\partial P}{\partial x} = \underbrace{\left. \frac{\partial P}{\partial \rho} \right|_s}_{=c^2} \frac{\partial \rho}{\partial x} + \left. \frac{\partial P}{\partial s} \right|_\rho \underbrace{\frac{\partial s}{\partial x}}_{=0}, \quad (9.233)$$

$$= c^2 \frac{\partial \rho}{\partial x}. \quad (9.234)$$

We next consider Eq. (9.228) in the limit where A is a constant and Eq. (9.229) where $\partial P/\partial x$ is replaced in favor of $\partial\rho/\partial x$ via Eq. (9.234):

$$\frac{\partial\rho}{\partial t} + \frac{\partial}{\partial x}(\rho\mathbf{v}) = 0, \quad (9.235)$$

$$\rho \left(\frac{\partial\mathbf{v}}{\partial t} + \mathbf{v} \frac{\partial\mathbf{v}}{\partial x} \right) = -c^2 \frac{\partial\rho}{\partial x}. \quad (9.236)$$

We next assume that the state variables ρ and \mathbf{v} are the sum of a constant state and a small perturbation:

$$\rho = \rho_o + \tilde{\rho}, \quad (9.237)$$

$$\mathbf{v} = \mathbf{0} + \tilde{\mathbf{v}}. \quad (9.238)$$

The velocity is assumed to be perturbed about zero, the stationary state. We substitute Eqs. (9.237-9.238) into Eqs. (9.235-9.236) to get

$$\frac{\partial}{\partial t}(\rho_o + \tilde{\rho}) + \frac{\partial}{\partial x}((\rho_o + \tilde{\rho})\tilde{\mathbf{v}}) = 0, \quad (9.239)$$

$$(\rho_o + \tilde{\rho}) \left(\frac{\partial\tilde{\mathbf{v}}}{\partial t} + \tilde{\mathbf{v}} \frac{\partial\tilde{\mathbf{v}}}{\partial x} \right) = -c^2 \frac{\partial}{\partial x}(\rho_o + \tilde{\rho}). \quad (9.240)$$

We expand to get

$$\underbrace{\frac{\partial\rho_o}{\partial t}}_{=0} + \frac{\partial\tilde{\rho}}{\partial t} + \rho_o \frac{\partial\tilde{\mathbf{v}}}{\partial x} + \underbrace{\frac{\partial}{\partial x}(\tilde{\rho}\tilde{\mathbf{v}})}_{\sim 0} = 0, \quad (9.241)$$

$$\rho_o \left(\frac{\partial\tilde{\mathbf{v}}}{\partial t} + \underbrace{\tilde{\mathbf{v}} \frac{\partial\tilde{\mathbf{v}}}{\partial x}}_{\sim 0} \right) + \underbrace{\tilde{\rho} \left(\frac{\partial\tilde{\mathbf{v}}}{\partial t} + \tilde{\mathbf{v}} \frac{\partial\tilde{\mathbf{v}}}{\partial x} \right)}_{\sim 0} = -c^2 \underbrace{\frac{\partial\rho_o}{\partial x}}_{=0} - c^2 \frac{\partial\tilde{\rho}}{\partial x}. \quad (9.242)$$

Neglecting terms involving the product of small terms, we are left with

$$\frac{\partial\tilde{\rho}}{\partial t} + \rho_o \frac{\partial\tilde{\mathbf{v}}}{\partial x} = 0, \quad (9.243)$$

$$\rho_o \frac{\partial\tilde{\mathbf{v}}}{\partial t} = -c^2 \frac{\partial\tilde{\rho}}{\partial x}. \quad (9.244)$$

Now, take the time derivative of Eq. (9.243) and the space derivative of Eq. (9.244) and get

$$\frac{\partial^2\tilde{\rho}}{\partial t^2} + \rho_o \frac{\partial^2\tilde{\mathbf{v}}}{\partial t\partial x} = 0, \quad (9.245)$$

$$\rho_o \frac{\partial^2\tilde{\mathbf{v}}}{\partial x\partial t} = -c^2 \frac{\partial^2\tilde{\rho}}{\partial x^2}. \quad (9.246)$$

Next, realizing the order of the mixed second partial derivatives does not matter for functions that are continuous and differentiable, we eliminate $\partial^2 \tilde{v} / \partial t \partial x$ and get

$$\frac{\partial^2 \tilde{\rho}}{\partial t^2} = c^2 \frac{\partial^2 \tilde{\rho}}{\partial x^2}. \quad (9.247)$$

Taking $P = P_o + \tilde{P}$, and using Eq. (9.199) for c^2 , we have

$$c^2 = k \frac{P}{\rho}, \quad (9.248)$$

$$= k \frac{P_o + \tilde{P}}{\rho_o + \tilde{\rho}}, \quad (9.249)$$

$$= k \frac{P_o \left(1 + \frac{\tilde{P}}{P_o}\right)}{\rho_o \left(1 + \frac{\tilde{\rho}}{\rho_o}\right)}, \quad (9.250)$$

$$= k \frac{P_o}{\rho_o} \left(1 + \frac{\tilde{P}}{P_o}\right) \left(1 - \frac{\tilde{\rho}}{\rho_o} + \dots\right), \quad (9.251)$$

$$= k \frac{P_o}{\rho_o} \left(1 + \frac{\tilde{P}}{P_o} - \frac{\tilde{\rho}}{\rho_o} + \dots\right). \quad (9.252)$$

We retain only the most important term and take then

$$c^2 = c_o^2 + \dots, \quad \text{with} \quad c_o^2 = k \frac{P_o}{\rho_o}. \quad (9.253)$$

So we get

$$\boxed{\frac{\partial^2 \tilde{\rho}}{\partial t^2} = c_o^2 \frac{\partial^2 \tilde{\rho}}{\partial x^2}}. \quad (9.254)$$

This is the well known wave equation that is satisfied by the well known d'Alembert solution:

$$\boxed{\tilde{\rho}(x, t) = f(x + c_o t) + g(x - c_o t)}. \quad (9.255)$$

It is named after Jean le Rond d'Alembert, see Fig. 9.10, Here, f and g are arbitrary functions. In a physical problem, they are determined by the actual initial and boundary conditions that are appropriate for the particular problem. The so-called "phase" ϕ of f is $\phi = x + c_o t$. We can find the speed of a point with constant phase by considering ϕ to be a constant, and taking appropriate derivatives:

$$\phi = \text{constant} = x + c_o t, \quad (9.256)$$

$$\frac{d\phi}{dt} = 0 = \frac{dx}{dt} + c_o, \quad (9.257)$$

$$\frac{dx}{dt} = -c_o. \quad (9.258)$$



Figure 9.10: Jean le Rond d'Alembert (1717-1783), French mathematician, physicist, and music theorist; image from https://en.wikipedia.org/wiki/Jean_le_Rond_d'Alembert.

Thus, waves described by $\tilde{\rho}(x, t) = f(x + c_o t)$ are traveling to the left (negative x direction) with speed c_o . Similarly the waves given by $g(x - c_o t)$ are traveling to the right (positive x direction) with speed c_o .

Example 9.11

Let us verify that $\tilde{\rho}(x, t) = f(x + c_o t)$ satisfies the wave equation, Eq. (9.254). The proof for $g(x - c_o t)$ is similar.

We simply need to calculate derivatives and then substitute into the original equation. The appropriate derivatives are

$$\frac{\partial \tilde{\rho}}{\partial t} = c_o f'(x + c_o t), \quad (9.259)$$

$$\frac{\partial^2 \tilde{\rho}}{\partial t^2} = c_o^2 f''(x + c_o t), \quad (9.260)$$

$$\frac{\partial \tilde{\rho}}{\partial x} = f'(x + c_o t), \quad (9.261)$$

$$\frac{\partial^2 \tilde{\rho}}{\partial x^2} = f''(x + c_o t). \quad (9.262)$$

Substituting into the wave equation, Eq. (9.254) gives

$$c_o^2 f''(x + c_o t) = c_o^2 f''(x + c_o t). \quad (9.263)$$

The wave equation is satisfied.

9.8.2 Compressible Bernoulli principle

We can employ the Bernoulli principle for a compressible CPIG to arrive at some common notions in compressible flow. This is best illustrated by examining the Bernoulli principle for an isentropic CPIG, Eq. (7.72) for a so-called stagnation flow, also neglecting gravity forces. A stagnation point is a point in the flow where the velocity is zero.

We take the common notation of “o” for a stagnation state. Then neglecting gravity forces, the Bernoulli principle, Eq. (7.72), can be recast as

$$\frac{k}{k-1} \frac{P}{\rho} + \frac{1}{2} v^2 = \frac{k}{k-1} \frac{P_o}{\rho_o} + \underbrace{\frac{1}{2} v^2}_0, \quad (9.264)$$

$$\frac{k}{k-1} \frac{P}{\rho} + \frac{1}{2} v^2 = \frac{k}{k-1} \frac{P_o}{\rho_o}. \quad (9.265)$$

We now use Eq. (9.199) to employ the square of the isentropic sound speed, taking $c^2 = kP/\rho = kRT$ and $c_o^2 = kP_o/\rho_o = kRT_o$. This gives

$$\frac{c^2}{k-1} + \frac{1}{2} v^2 = \frac{c_o^2}{k-1}, \quad (9.266)$$

$$1 + \frac{k-1}{2} \frac{v^2}{c^2} = \frac{c_o^2}{c^2}, \quad (9.267)$$

$$1 + \frac{k-1}{2} \frac{v^2}{c^2} = \frac{kRT_o}{kRT}, \quad (9.268)$$

$$1 + \frac{k-1}{2} \frac{v^2}{c^2} = \frac{T_o}{T}. \quad (9.269)$$

Now, we define the *Mach number*, M , as the ratio of the fluid velocity to the sound speed, so that

$$M^2 = \frac{v^2}{c^2}. \quad (9.270)$$

Thus

$$\frac{T_o}{T} = 1 + \frac{k-1}{2} M^2. \quad (9.271)$$

So we see that the stagnation temperature T_o rises with Mach number. This represents a conversion of kinetic energy to thermal energy as the fluid decelerates to the stagnation condition. Then, we can use our isentropic relations for a CPIG, Eq. (6.169), to say

$$\frac{T_o}{T} = \left(\frac{P_o}{P} \right)^{\frac{k-1}{k}} = 1 + \frac{k-1}{2} M^2. \quad (9.272)$$

Rearranging, we get

$$\frac{P_o}{P} = \left(1 + \frac{k-1}{2}M^2\right)^{\frac{k}{k-1}}. \quad (9.273)$$

Taylor series of this equation about $M = 0$ yields

$$\frac{P_o}{P} = 1 + \frac{k}{2}M^2 + \frac{k}{8}M^4 + \dots, \quad (9.274)$$

$$= 1 + \frac{k}{2}M^2 \left(1 + \frac{1}{4}M^2 + \dots\right), \quad (9.275)$$

$$= 1 + \frac{k}{2} \frac{\rho v^2}{kP} \left(1 + \frac{1}{4}M^2 + \dots\right), \quad (9.276)$$

$$= 1 + \frac{\rho v^2}{2P} \left(1 + \frac{1}{4}M^2 + \dots\right), \quad (9.277)$$

$$P_o = P + \frac{\rho v^2}{2} \left(1 + \frac{1}{4}M^2 + \dots\right). \quad (9.278)$$

For $M = 0$, we recover the incompressible Bernoulli principle, see Eq. (7.65), and the correction at small finite Mach number to the incompressible Bernoulli principle estimate for stagnation pressure is evident.

Note, we can also achieve Eq. (9.271) by simple modification to our first law equation for an isentropic nozzle, Eq. (4.268), to get the simple.

$$h_o = h + \frac{v^2}{2}, \quad (9.279)$$

$$h_o - h = \frac{v^2}{2}, \quad (9.280)$$

$$c_P(T_o - T) = \frac{v^2}{2}, \quad (9.281)$$

$$T_o = T + \frac{v^2}{2c_P}, \quad (9.282)$$

$$\frac{T_o}{T} = 1 + \frac{v^2}{2c_P T}, \quad (9.283)$$

$$= 1 + \frac{kR}{2c_P} \frac{v^2}{kRT}, \quad (9.284)$$

$$= 1 + \frac{c_P}{c_v} \frac{c_P - c_v}{2c_P} M^2, \quad (9.285)$$

$$= 1 + \frac{k-1}{2} M^2. \quad (9.286)$$

Example 9.12

A high Mach number vehicle travels at $M = 5$ into air at $T = 300$ K, $P = 100$ kPa. Find the stagnation temperature and pressure at the leading edge of the vehicle. Neglect all effects of shock

waves and non-ideal gas effects and assume isentropic CPIG air. Compare the stagnation pressure to predictions of various versions of the Bernoulli principle.

We first apply Eq. (9.272) and find

$$T_o = T \left(1 + \frac{k-1}{2} M^2 \right), \quad (9.287)$$

$$= (300 \text{ K}) \left(1 + \frac{7}{5} \frac{1}{2} 5^2 \right), \quad (9.288)$$

$$= \boxed{1800 \text{ K.}} \quad (9.289)$$

The temperature increased significantly as the kinetic energy was converted to thermal energy. As a consequence, the vehicle is subjected an extreme thermal environment.

For the stagnation pressure, Eq. (9.273) gives

$$P_o = P \left(1 + \frac{k-1}{2} M^2 \right)^{\frac{k}{k-1}}, \quad (9.290)$$

$$= (100 \text{ kPa}) \left(1 + \frac{7}{5} \frac{1}{2} 5^2 \right)^{\frac{7/5}{7/5-1}}, \quad (9.291)$$

$$= \boxed{52909 \text{ kPa.}} \quad (9.292)$$

The pressure rose by a factor of 529, so the mechanical stress on the vehicle is very high. These predictions are really crude estimates. Both shock waves and non-ideal effects would play a significant role for a real vehicle, and this would need to be considered in any realistic design.

Now let us examine the predictions of less accurate versions of the Bernoulli principle. For this we need the ambient density, which by the ideal gas law is

$$\rho = \frac{P}{RT} = \frac{10^5 \text{ Pa}}{\left(287 \frac{\text{J}}{\text{kg K}} \right) (300 \text{ K})} = 1.16144 \frac{\text{kg}}{\text{m}^3}. \quad (9.293)$$

We also need the ambient sound speed, which for the ideal gas is

$$c = \sqrt{kRT} = \sqrt{\frac{7}{5} \left(287 \frac{\text{J}}{\text{kg K}} \right) (300 \text{ K})} = 347.189 \frac{\text{m}}{\text{s}} \quad (9.294)$$

Thus, the flight velocity is

$$v = Mc = 5 \left(347.189 \frac{\text{m}}{\text{s}} \right) = 1735.94 \frac{\text{m}}{\text{s}}. \quad (9.295)$$

In the incompressible limit, we artificially take $M = 0$ and reduce Eq. (9.278) to the incompressible Bernoulli principle:

$$P_o \approx P + \frac{\rho v^2}{2}, \quad (9.296)$$

$$= (10^5 \text{ Pa}) + \frac{\left(1.16144 \frac{\text{kg}}{\text{m}^3} \right) \left(1735.94 \frac{\text{m}}{\text{s}} \right)^2}{2}, \quad (9.297)$$

$$= 1.85 \times 10^6 \text{ Pa}, \quad (9.298)$$

$$= \boxed{1850 \text{ kPa.}} \quad (9.299)$$

The prediction of the incompressible Bernoulli principle has significant error! It under-predicts the pressure by a factor of 28.6. Let us see how the corrected approximation does. Applying Eq. (9.278), we get the approximation

$$P_o \approx P + \frac{\rho v^2}{2} \left(1 + \frac{1}{4} M^2\right), \quad (9.300)$$

$$= (10^5 \text{ Pa}) + \frac{\left(1.16144 \frac{\text{kg}}{\text{m}^3}\right) \left(1735.94 \frac{\text{m}}{\text{s}}\right)^2}{2} \left(1 + \frac{5^2}{4}\right), \quad (9.301)$$

$$= 1.27875 \times 10^7 \text{ Pa}, \quad (9.302)$$

$$= \boxed{12787.5 \text{ kPa}}. \quad (9.303)$$

This approximation is better, but still differs by a factor of 4.13 from the actual value. One notes that the approximations were developed from a Taylor series in the limit of small Mach number, and the Mach number here is not small. So there is no surprise that the approximate formula do not work well.

9.8.3 Steady flow with area change

Let us now return to the full equations, Eqs. (9.228-9.231). In particular, we will now consider potentially large fluid velocities, v ; more specifically, the kinetic energy changes of the flow may be as important as the internal energy changes. Let us also consider only steady flows; thus, $\partial/\partial t = 0$. Our governing equations, Eqs. (9.228-9.231), reduce to

$$\frac{d}{dx} (\rho v A) = 0, \quad (9.304)$$

$$\rho v \frac{dv}{dx} = -\frac{dP}{dx}, \quad (9.305)$$

$$\frac{ds}{dx} = 0, \quad (9.306)$$

$$P = P(\rho, s). \quad (9.307)$$

Specializing Eq. (9.234) for steady flows, we have

$$\frac{dP}{dx} = c^2 \frac{d\rho}{dx}. \quad (9.308)$$

Using Eq. (9.308), in the linear momentum equation, Eq. (9.305), and expanding the mass equation, Eq. (9.304), our mass and linear momentum equations become

$$\rho v \frac{dA}{dx} + \rho A \frac{dv}{dx} + v A \frac{d\rho}{dx} = 0, \quad (9.309)$$

$$\rho v \frac{dv}{dx} = -c^2 \frac{d\rho}{dx}. \quad (9.310)$$

We next use Eq. (9.310) to eliminate $d\rho/dx$ in the mass equation, Eq. (9.309), to get

$$\rho v \frac{dA}{dx} + \rho A \frac{dv}{dx} + v A \left(-\frac{\rho v}{c^2} \frac{dv}{dx} \right) = 0, \quad (9.311)$$

$$\frac{1}{A} \frac{dA}{dx} + \frac{1}{v} \frac{dv}{dx} - \frac{v}{c^2} \frac{dv}{dx} = 0, \quad (9.312)$$

$$\frac{1}{v} \frac{dv}{dx} \left(1 - \frac{v^2}{c^2} \right) = -\frac{1}{A} \frac{dA}{dx}, \quad (9.313)$$

$$\frac{dv}{dx} = \frac{\frac{v}{A} \frac{dA}{dx}}{\frac{v^2}{c^2} - 1}. \quad (9.314)$$

Recalling the Mach number, Eq. (9.270), $M \equiv v/c$, we can restate Eq. (9.314) as

$$\frac{dv}{dx} = \frac{\frac{v}{A} \frac{dA}{dx}}{M^2 - 1}. \quad (9.315)$$

Notice when the Mach number is unity, there is a potential singularity in dv/dx . This caused great concern in the design of early supersonic vehicles. The only way to prevent the singular behavior is to require at a sonic point, where $M = 1$, for dA/dx to be simultaneously zero. Remarkably, this is precisely how nature behaves and is the reason why supersonic nozzles are first converging, then diverging. At the point where $dA/dx = 0$, the flow becomes locally sonic and can undergo a transition from subsonic to supersonic.

In terms of differentials, we can restate Eq. (9.315) as

$$\boxed{\frac{dv}{v} = \frac{1}{M^2 - 1} \frac{dA}{A}}. \quad (9.316)$$

Note, if the flow is subsonic, $M < 1$, with $v > 0$ and area increasing $dA > 0$, then $dv < 0$: *area increase in a subsonic nozzle generates velocity decrease*. For supersonic flow, the opposite is true: *area increase in a supersonic nozzle generates velocity increase*. One can see a converging-diverging nozzle as well as its use in generating supersonic flow at its exit plane in an image of a 2010 space shuttle launch depicted in Fig. 9.11.



a)



b)

Figure 9.11: a) diverging section of a nozzle for the space shuttle main engine; image from https://en.wikipedia.org/wiki/Space_Shuttle_main_engine, b) Launch of Space Shuttle Atlantis, STS-132, 14 May 2010, with a crew including astronaut Michael T. Good, BSAE 1984, MSAE 1986, University of Notre Dame; image from <http://www.nasa.gov>.

Appendix

This appendix will consider two peripheral topics: Legendre transformations, first introduced in Sec. 9.3, and the method of least squares.

Legendre transformations

Here we will draw upon the work of Zia, *et al.*¹⁰ to better understand Legendre transformations in general and how they relate to thermodynamics. The method is general and is often applied to other problems in physics, especially in dynamics.

Consider a function $F(x)$. Let us insist that F be such that

$$\frac{d^2F}{dx^2} \geq 0.$$

That is to say, its slope increases or does not change as x increases. Such a function may possess a minimum value, and can be considered to be *convex*. Formally, one can say that F is convex when the region above it, known as the *epigraph*, forms a so-called *convex set*. A set is convex if special linear combinations of any of its elements also reside within the set. Examples of convex and non-convex functions are shown in Fig. 9.12. For the convex function $F(x) = x^2$, shown in Fig. 9.12a, we have $d^2F/dx^2 = 2 > 0$. We also see that special linear combinations of any points within the epigraph will lie within the epigraph. Mathematically, this is expressed as follows: for $s \in [0, 1]$ we must have $F(sx_1 + (1-s)x_2) \leq sF(x_1) + (1-s)F(x_2)$. This is illustrated by a sample line whose interior points all lie within the epigraph. For the non-convex function $F(x) = x^3 - x^2 - x$, shown in Fig. 9.12b, we have $d^2F/dx^2 = 6x - 2$. Obviously, this is not positive for all x , and so the function is non-convex. And we see that lines exist connecting points within the epigraph that contain points outside of the epigraph. Hence it is non-convex.

Let us define the slope of F as w . Mathematically, we can say

$$\frac{dF}{dx} = w(x).$$

Because F is a function of x , its derivative also is a function of x . Now because we have insisted that w is increasing as x increases, we can always find a unique inverse such that

¹⁰R. K. P. Zia, E. F. Redish, and S. R. McKay, 2009, "Making sense of the Legendre transform," *American Journal of Physics*, 77(7): 614-622.

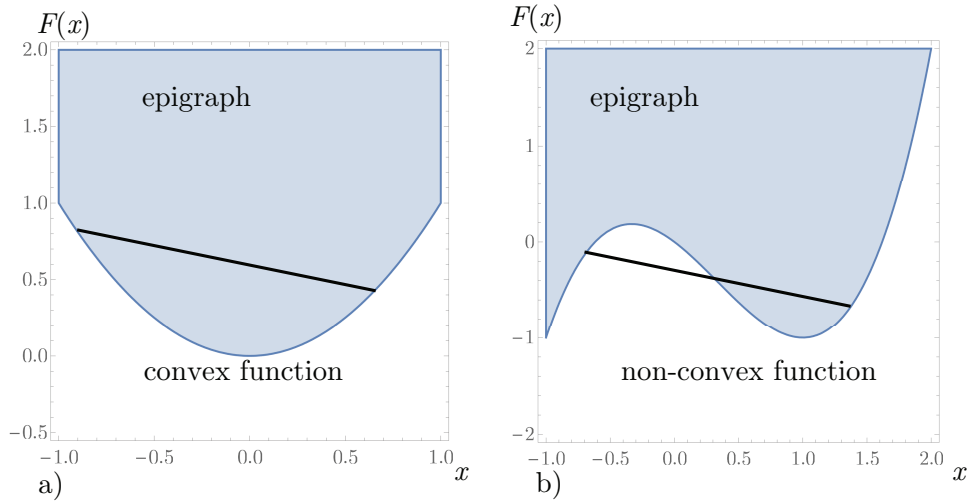

Figure 9.12: Plots illustrating a) the convex function $F(x) = x^2$ and b) the non-convex function $F(x) = x^3 - x^2 - x$.

$x(w)$ exists. That is to say, just as the slope is a function of x , x can be identified as a function of slope. Now let us define the Legendre transform G as

$$G(w) = wx(w) - F(x(w)).$$

Given $F(x)$, and convexity, it is always possible to compute G . We can write this in a form that will be more useful for thermodynamics:

$$G(w) + F(x) = wx.$$

Here we see a symmetry in the relationship. Now differentiate G with respect to w . We get

$$\frac{dG}{dw} = w \frac{dx}{dw} + x(w) - \frac{dF}{dx} \frac{dx}{dw}.$$

Rearrange to get

$$\frac{dG}{dw} = \frac{dx}{dw} \underbrace{\left(w - \frac{dF}{dx} \right)}_0 + x(w)$$

Now because $dF/dx = w$, we get $dG/dw = x$. Thus we get a set of symmetric relations

$$\frac{dF}{dx} = w, \quad \frac{dG}{dw} = x.$$

We could also say then that

$$G(w) + F(x) = \frac{dG}{dw} \frac{dF}{dx}.$$

It can remarkably be shown that the Legendre transformation of G returns us to the original function F .

Example 9.1

Find the Legendre transformation of $F(x) = e^x$.

First, we find that

$$w = \frac{dF}{dx} = \frac{d}{dx}(e^x) = e^x.$$

We also see that

$$\frac{d^2F}{dx^2} = e^x > 0,$$

so F is convex. We also see that $w(x)$ exists, as does its inverse $x(w)$:

$$w(x) = e^x, \quad x(w) = \ln w.$$

For the inverse to be real valued, we must require that $w > 0$, which is the case for $w = e^x$. So

$$\begin{aligned} G(w) &= wx(w) - F(x(w)), \\ &= w \ln w - \exp(\ln w), \\ &= w \ln w - w, \\ &= w(\ln w - 1). \end{aligned}$$

Example 9.2

Find the Legendre transformation of $F(x) = x(\ln x - 1)$. Note the function F has the same form as the Legendre transformation of e^x studied in the previous example.

We easily see that

$$\frac{dF}{dx} = \ln x,$$

so

$$w(x) = \ln x.$$

We also see that

$$\frac{d^2F}{dx^2} = \frac{1}{x},$$

so F is convex as long as $x > 0$. We then get that

$$x(w) = e^w.$$

The Legendre transformation is

$$\begin{aligned} G(w) &= wx(w) - F(x(w)), \\ &= we^w - e^w(\ln e^w - 1), \\ &= we^w - e^w(w - 1), \\ &= e^w. \end{aligned}$$

The Legendre transform of the Legendre transform returns us to the original function. Thus, the transform is its own inverse.

Example 9.3

Find the Legendre transformation of $F(x) = x^2$.

First, we find that

$$w = \frac{dF}{dx} = \frac{d}{dx}(x^2) = 2x.$$

We also see that

$$\frac{d^2F}{dx^2} = 2,$$

so F is convex. We also see that $w(x)$ exists, as does its inverse $x(w)$:

$$w(x) = 2x, \quad x(w) = \frac{w}{2}.$$

So

$$\begin{aligned} G(w) &= wx(w) - F(x(w)), \\ &= w \frac{w}{2} - \left(\frac{w}{2}\right)^2, \\ &= \frac{w^2}{4}. \end{aligned}$$

Example 9.4

Find the Legendre transformation of $F(x) = x^2/4$. Note the function F has the same form as the Legendre transformation of x^2 studied in the previous example.

We easily see that

$$\frac{dF}{dx} = \frac{x}{2},$$

so

$$w(x) = \frac{x}{2}.$$

We also see that

$$\frac{d^2F}{dx^2} = \frac{1}{2},$$

so F is convex. We then get that

$$x(w) = 2w.$$

The Legendre transformation is

$$\begin{aligned}
 G(w) &= wx(w) - F(x(w)), \\
 &= w(2w) - \frac{1}{4}(2w)^2, \\
 &= 2w^2 - w^2, \\
 &= w^2.
 \end{aligned}$$

The Legendre transform of the Legendre transform returns us to the original function. Thus, the transform is its own inverse.

Let us see how this fits with thermodynamics. We will need some unusual notation to identify the similarities. Let us take

$$\tilde{P} \equiv -P, \quad \tilde{h} \equiv -h, \quad \tilde{a} \equiv -a, \quad \tilde{g} \equiv -g.$$

Our definition of enthalpy, $h = u + Pv$, can be rewritten as

$$u - h = -Pv.$$

Now recall from Eq. (9.8) that the canonical form for u is $u(v, s)$, and that from Eq. (9.35), the canonical form for h is $h(P, s)$. Also invoking Eq. (9.10) to eliminate P and Eq. (9.40) to eliminate v , we get

$$u(v, s) - h(P, s) = \left. \frac{\partial u}{\partial v} \right|_s - \left. \frac{\partial h}{\partial P} \right|_s.$$

In terms of \tilde{P} and \tilde{h} , we could say

$$u(v, s) + \tilde{h}(\tilde{P}, s) = \left. \frac{\partial u}{\partial v} \right|_s + \left. \frac{\partial \tilde{h}}{\partial \tilde{P}} \right|_s.$$

Recognizing that s is a frozen variable here, we see that this is precisely the form of the Legendre transformation $G(w) + F(x) = wx$, with $dF/dx = w$, $dG/dw = x$. We could also say

$$u(v, s) = v\tilde{P}(v, s) - \tilde{h}(\tilde{P}(v, s), s),$$

to be consistent with the original form $G(w) = wx(w) - F(x(w))$. Rearranging gives

$$(-\tilde{h}(\tilde{P}(v, s), s)) = u(v, s) + (-\tilde{P}(v, s))v,$$

$$h(P(v, s), s) = u(v, s) + P(v, s)v.$$

Let us repeat this for a and g . First for Helmholtz free energy from Eq. (9.42) we get

$$u - a = Ts.$$

Invoking Eqs. (9.10) and (9.47), we get

$$u - a = \left. \frac{\partial u}{\partial s} \right|_v \left(- \left. \frac{\partial a}{\partial T} \right|_v \right).$$

In terms of \tilde{a} , we get

$$u(s, v) + \tilde{a}(T, v) = \left. \frac{\partial u}{\partial s} \right|_v \left. \frac{\partial \tilde{a}}{\partial T} \right|_v.$$

Recognizing that v is a frozen variable here, we once again see that this is precisely the form of the Legendre transformation $G(w) + F(x) = wx$, with $dF/dx = w$, $dG/dw = x$.

For Gibbs free energy, from Eq. (9.50), we can say

$$h - g = Ts.$$

Invoking Eqs. (9.40) and (9.55), we can say

$$h - g = \left. \frac{\partial h}{\partial s} \right|_P \left(- \left. \frac{\partial g}{\partial T} \right|_P \right).$$

Invoking \tilde{g} , we can say

$$h(s, P) + \tilde{g}(T, P) = \left. \frac{\partial h}{\partial s} \right|_P \left. \frac{\partial \tilde{g}}{\partial T} \right|_P.$$

Recognizing that P is a frozen variable here, we once again see that this is precisely the form of the Legendre transformation $G(w) + F(x) = wx$, with $dF/dx = w$, $dG/dw = x$.

Method of least squares

One important application of data analysis is the method of least squares. This method is often used to fit data to a given functional form. The form is most often in terms of polynomials, but there is absolutely no restriction; trigonometric functions, logarithmic functions, Bessel functions can all serve as well. Here, we will restrict ourselves to strictly scalar functions of the form

$$x = f(t; a_j), \quad j = 1, \dots, M,$$

where x is a dependent variable, t is an independent variable, f is an assumed functional form, and a_j is a set of M constant parameters in the functional form. The analysis can easily be extended for functions of many variables. General mathematical background is given by Strang.¹¹

Mathematically, the fundamental problem is, given

- a set of N discrete data points, $x_i, t_i, i = 1, \dots, N$, and

¹¹G. Strang, 1988, *Linear Algebra and its Application*, Harcourt Brace Jovanovich, Orlando, Florida.

- an assumed functional form for the curve fit $f(t; a_j)$ that has M parameters a_j , $j = 1, \dots, M$,

find the *best set of parameter values* a_j so as to minimize the least squares error between the curve fit and the actual data points. That is, the problem is to find a_j , $j = 1, \dots, M$, such that

$$\ell_2 = \|x_i - f(t_i; a_j)\|_2 \equiv \sqrt{\sum_{i=1}^N (x_i - f(t_i; a_j))^2},$$

is minimized. Here, ℓ_2 represents a total error of the approximation. It is sometimes called a “norm” of the approximation or an “L-two norm.” The notation $\|\cdot\|_2$ represents the L-two norm of a vector represented by “.” In that it is a square root of the sum of squares, it can be thought of as an unusual distance, as motivated by Pythagoras¹² theorem.

In the least squares method, one

- examines the data,
- makes a non-unique judgment of what the functional form might be,
- substitutes each data point into the assumed form so as to form an over-constrained system of equations,
- uses straightforward techniques from linear algebra to solve for the coefficients that best represent the given data *if* the problem is linear in the coefficients a_j ,
- uses techniques from optimization theory to solve for the coefficients that best represent the given data *if* the problem is non-linear in a_j .

The most general problem, in which the dependency a_j is non-linear, is difficult, and sometimes impossible. For cases in which the functional form is linear in the coefficients a_j or can be rendered linear via simple transformation, it is possible to get a unique representation of the best set of parameters a_j . This is often the case for common curve fits such as straight line, polynomial, or logarithmic fits.

Let us first consider polynomial curve fits. Now, if one has say, ten data points, one can in principle, find a ninth order polynomial that will pass through all the data points. Often times, especially when there is much experimental error in the data, such a function may be subject to wild oscillations, that are unwarranted by the underlying physics, and thus is not useful as a predictive tool. In such cases, it may be more useful to choose a lower order curve that does not exactly pass through all experimental points, but that does minimize the error.

Unweighted least squares

This is the most common method used when one has equal confidence in all the data.

¹²Pythagoras of Samos, c. 570 B.C.-495 B.C., Ionian Greek philosopher and mathematician.

Example 9.5

Find the best straight line to approximate the measured data relating x to t .

| t | x |
|-----|-----|
| 0 | 5 |
| 1 | 7 |
| 2 | 10 |
| 3 | 12 |
| 6 | 15 |

A straight line fit will have the form

$$x = a_1 + a_2 t,$$

where a_1 and a_2 are the terms to be determined. Substituting each data point to the assumed form, we get five equations in two unknowns:

$$\begin{aligned} 5 &= a_1 + 0a_2, \\ 7 &= a_1 + 1a_2, \\ 10 &= a_1 + 2a_2, \\ 12 &= a_1 + 3a_2, \\ 15 &= a_1 + 6a_2. \end{aligned}$$

This is an over-constrained problem, and there is no unique solution that satisfies all of the equations! If a unique solution existed, then the curve fit would be perfect. However, there does exist a solution that minimizes the error, as is often proved in linear algebra textbooks (and will not be proved here). The procedure is straightforward. Rearranging, we get

$$\begin{pmatrix} 1 & 0 \\ 1 & 1 \\ 1 & 2 \\ 1 & 3 \\ 1 & 6 \end{pmatrix} \begin{pmatrix} a_1 \\ a_2 \end{pmatrix} = \begin{pmatrix} 5 \\ 7 \\ 10 \\ 12 \\ 15 \end{pmatrix}.$$

This is of the form $\mathbf{A} \cdot \mathbf{a} = \mathbf{b}$. We then find

$$\begin{aligned} \mathbf{A}^T \cdot \mathbf{A} \cdot \mathbf{a} &= \mathbf{A}^T \cdot \mathbf{b}, \\ \mathbf{a} &= (\mathbf{A}^T \cdot \mathbf{A})^{-1} \cdot \mathbf{A}^T \cdot \mathbf{b}. \end{aligned}$$

Substituting, we find that

$$\begin{pmatrix} a_1 \\ a_2 \end{pmatrix} = \left[\begin{pmatrix} 1 & 0 \\ 1 & 1 \\ 1 & 2 \\ 1 & 3 \\ 1 & 6 \end{pmatrix} \right]^{-1} \begin{pmatrix} 1 & 1 & 1 & 1 & 1 \\ 0 & 1 & 2 & 3 & 6 \end{pmatrix} \begin{pmatrix} 5 \\ 7 \\ 10 \\ 12 \\ 15 \end{pmatrix} = \begin{pmatrix} 5.7925 \\ 1.6698 \end{pmatrix}.$$

So the best fit estimate is

$$x = 5.7925 + 1.6698 t.$$

The least squares error is $\|\mathbf{A} \cdot \mathbf{a} - \mathbf{b}\|_2 = 1.9206$. This represents what is known as the ℓ_2 error norm of the prediction. In **MATLAB**, this is found by the command `norm(A * a - b)` where \mathbf{A} , \mathbf{a} , and \mathbf{b} are the coefficient matrix \mathbf{A} , the solution \mathbf{a} and the input vector \mathbf{b} , respectively. If the curve fit were perfect, the error norm would be zero. A plot of the raw data and the best fit straight line is shown in Fig. 9.13.

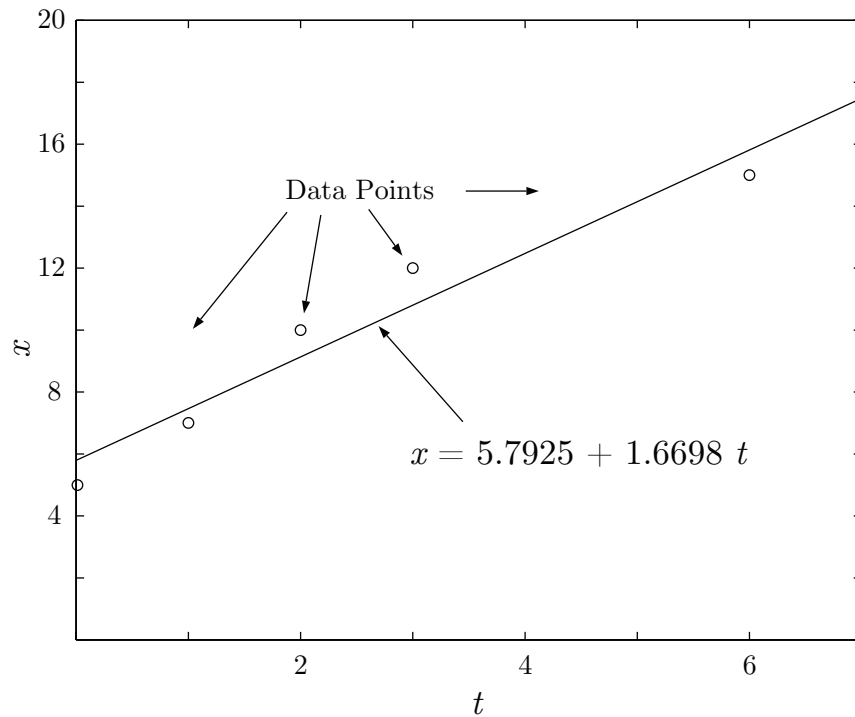

Figure 9.13: Plot of $x - t$ data and best least squares straight line fit.

Weighted least squares

If one has more confidence in some data points than others, one can define a weighting function to give more priority to those particular data points.

Example 9.6

Find the best straight line fit for the data in the previous example. Now however, assume that we have five times the confidence in the accuracy of the final two data points, relative to the other points. Define a square weighting matrix \mathbf{W} :

$$\mathbf{W} = \begin{pmatrix} 1 & 0 & 0 & 0 & 0 \\ 0 & 1 & 0 & 0 & 0 \\ 0 & 0 & 1 & 0 & 0 \\ 0 & 0 & 0 & 5 & 0 \\ 0 & 0 & 0 & 0 & 5 \end{pmatrix}.$$

Now, we perform the following operations:

$$\begin{aligned} \mathbf{A} \cdot \mathbf{a} &= \mathbf{b}, \\ \mathbf{W} \cdot \mathbf{A} \cdot \mathbf{a} &= \mathbf{W} \cdot \mathbf{b}, \\ (\mathbf{W} \cdot \mathbf{A})^T \cdot \mathbf{W} \cdot \mathbf{A} \cdot \mathbf{a} &= (\mathbf{W} \cdot \mathbf{A})^T \cdot \mathbf{W} \cdot \mathbf{b}, \\ \mathbf{a} &= \left((\mathbf{W} \cdot \mathbf{A})^T \cdot \mathbf{W} \cdot \mathbf{A} \right)^{-1} (\mathbf{W} \cdot \mathbf{A})^T \cdot \mathbf{W} \cdot \mathbf{b}. \end{aligned}$$

With the above values of \mathbf{W} , direct substitution leads to

$$\mathbf{a} = \begin{pmatrix} a_1 \\ a_2 \end{pmatrix} = \begin{pmatrix} 8.0008 \\ 1.1972 \end{pmatrix}.$$

So the best weighted least squares fit is

$$x = 8.0008 + 1.1972 t.$$

A plot of the raw data and the best fit straight line is shown in Fig. 9.14.

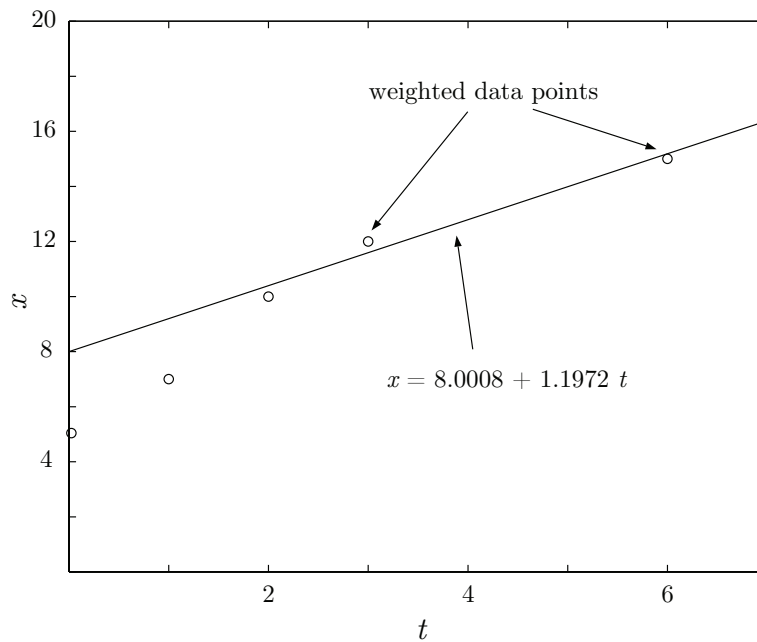

Figure 9.14: Plot of $x - t$ data and best weighted least squares straight line fit.

When the measurements are independent and equally reliable, \mathbf{W} is the identity matrix. If the measurements are independent but not equally reliable, \mathbf{W} is at most diagonal. If the measurements are not independent, then non-zero terms can appear off the diagonal in \mathbf{W} . It is often advantageous, for instance in problems in which one wants to control a process in real time, to give priority to recent data estimates over old data estimates and to continually

employ a least squares technique to estimate future system behavior. The previous example does just that. A famous fast algorithm for such problems is known as a *Kalman*¹³ *Filter*.

Power law/logarithmic curve fits

It is common and useful at times to fit data to a power law form, especially when the data range over wide orders of magnitude. For clean units, it is advisable to scale both x and t by characteristic values. Sometimes this is obvious, and sometimes it is not. Whatever the case, the following form can usually be found

$$\frac{x(t)}{x_c} = a_1 \left(\frac{t}{t_c} \right)^{a_2}.$$

Here, x is a dependent variable, t is an independent variable, x_c is a characteristic value of x (perhaps its maximum), t_c is a characteristic value of t (perhaps its maximum), and a_1 and a_2 are curve fit parameters. This fit is not linear in the coefficients, but can be rendered so by taking the logarithm of both sides to get

$$\ln \left(\frac{x(t)}{x_c} \right) = \ln \left(a_1 \left(\frac{t}{t_c} \right)^{a_2} \right) = \ln(a_1) + a_2 \ln \left(\frac{t}{t_c} \right).$$

Often times one must not include values at $t = 0$ because of the logarithmic singularity there.

Example 9.7

An experiment yields some data, shown next.

| $t(\text{s})$ | $x(\text{nm})$ |
|--------------------|--------------------|
| 0.0 | 0.0 |
| 1×10^{-3} | 1×10^0 |
| 1×10^{-2} | 5×10^1 |
| 1×10^0 | 3×10^5 |
| 1×10^1 | 7×10^9 |
| 1×10^2 | 8×10^{10} |

Analyze.

A plot of the raw data is shown in Fig. 9.15. Notice that the linear plot obscures the data at small time, while the log-log plot makes the trends more clear. Now, to get a curve fit for the log-log plot, we assume a power law form. We first eliminate the point at the origin, then scale the data, in this case by the maximum values of t and x , and take appropriate logarithms to get the following values.

| t (s) | x (nm) | t/t_{max} | x/x_{max} | $\ln \left(\frac{t}{t_{max}} \right)$ | $\ln \left(\frac{x}{x_{max}} \right)$ |
|--------------------|--------------------|--------------------|------------------------|--|--|
| 1×10^{-3} | 1×10^0 | 1×10^{-5} | 1.25×10^{-11} | -11.5129 | -25.1053 |
| 1×10^{-2} | 5×10^1 | 1×10^{-4} | 6.25×10^{-10} | -9.2013 | -21.1933 |
| 1×10^0 | 3×10^5 | 1×10^{-2} | 3.75×10^{-6} | -4.6052 | -12.4938 |
| 1×10^1 | 7×10^9 | 1×10^{-1} | 8.75×10^{-2} | -2.3026 | -2.4361 |
| 1×10^2 | 8×10^{10} | 1×10^0 | 1×10^0 | 0.0000 | 0.0000 |

¹³Rudolf Emil Kálmán, 1930-2016, Hungarian-American electrical engineer.

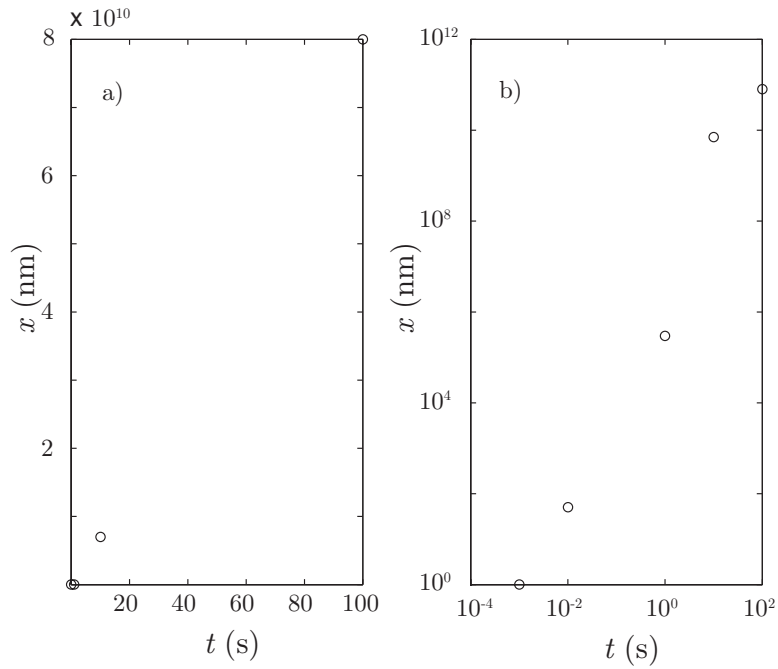

Figure 9.15: Plot of $x - t$ data in a) linear and b) log-log plots.

Now, we prepare the system of linear equations to solve

$$\begin{aligned}
 \ln\left(\frac{x}{x_{max}}\right) &= \ln a_1 + a_2 \ln\left(\frac{t}{t_{max}}\right), \\
 -25.1053 &= \ln a_1 + a_2(-11.5129), \\
 -21.1933 &= \ln a_1 + a_2(-9.2013), \\
 -12.4938 &= \ln a_1 + a_2(-4.6052), \\
 -2.4361 &= \ln a_1 + a_2(-2.3026), \\
 0.0000 &= \ln a_1 + a_2(0.0000).
 \end{aligned}$$

In matrix form, this becomes

$$\begin{pmatrix} 1 & -11.5129 \\ 1 & -9.2013 \\ 1 & -4.6052 \\ 1 & -2.3026 \\ 1 & 0.0000 \end{pmatrix} \begin{pmatrix} \ln a_1 \\ a_2 \end{pmatrix} = \begin{pmatrix} -25.1053 \\ -21.1933 \\ -12.4938 \\ -2.4361 \\ 0.0000 \end{pmatrix}.$$

This is of the form

$$\mathbf{A} \cdot \mathbf{a} = \mathbf{b}.$$

As before, we multiply both sides by \mathbf{A}^T and then solve for \mathbf{a} , we get

$$\mathbf{a} = (\mathbf{A}^T \cdot \mathbf{A})^{-1} \cdot \mathbf{A}^T \cdot \mathbf{b}.$$

Solving, we find

$$\mathbf{a} = \begin{pmatrix} 0.4206 \\ 2.2920 \end{pmatrix}.$$

So that

$$\ln a_1 = 0.4206, \quad a_2 = 2.2920,$$

or

$$a_1 = 1.5228.$$

So the power law curve fit is

$$\frac{x(t)}{8.000 \times 10^{10} \text{ nm}} = 1.5228 \left(\frac{t}{100 \text{ s}} \right)^{2.2920},$$

or

$$x(t) = (1.2183 \times 10^{11} \text{ nm}) \left(\frac{t}{100 \text{ s}} \right)^{2.2920}.$$

A plot of the raw data and curve fit is shown in Fig. 9.16.

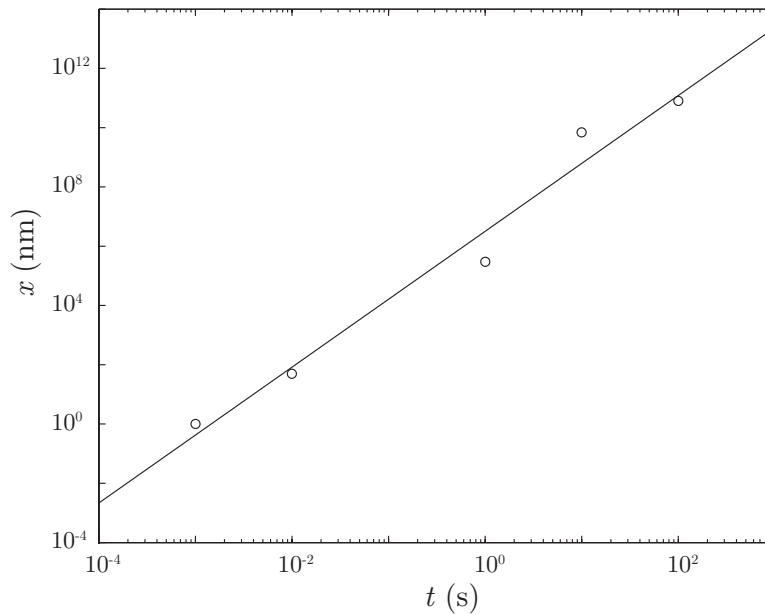

Figure 9.16: Plot of raw $x - t$ data and power law curve fit to the data: $x(t) = (1.2183 \times 10^{11} \text{ nm}) \left(\frac{t}{100 \text{ s}} \right)^{2.2920}$.

Higher order curve fits

As long as the assumed form for the curve fit is linear in the coefficients, it is straightforward to extend to high order curve fits as demonstrated in the following example.

Example 9.8

An experiment yields the data that follows.

| t | x |
|-----|-----|
| 0.0 | 1.0 |
| 0.7 | 1.6 |
| 0.9 | 1.8 |
| 1.5 | 2.0 |
| 2.6 | 1.5 |
| 3.0 | 1.1 |

Find the least squares best fit coefficients a_1 , a_2 , and a_3 if the assumed functional form is

1. $x = a_1 + a_2t + a_3t^2$,
2. $x = a_1 + a_2 \sin\left(\frac{t}{6}\right) + a_3 \sin\left(\frac{t}{3}\right)$.

Plot on a single graph the data points and the two best fit estimates. Which best fit estimate has the smallest least squares error?

-
- $x = a_1 + a_2t + a_3t^2$:

We substitute each data point into the assumed form and get the following set of linear equations

$$\begin{aligned} 1.0 &= a_1 + a_2(0.0) + a_3(0.0)^2, \\ 1.6 &= a_1 + a_2(0.7) + a_3(0.7)^2, \\ 1.8 &= a_1 + a_2(0.9) + a_3(0.9)^2, \\ 2.0 &= a_1 + a_2(1.5) + a_3(1.5)^2, \\ 1.5 &= a_1 + a_2(2.6) + a_3(2.6)^2, \\ 1.1 &= a_1 + a_2(3.0) + a_3(3.0)^2. \end{aligned}$$

These can be rewritten as

$$\begin{pmatrix} 1 & 0.0 & 0.0 \\ 1 & 0.7 & 0.49 \\ 1 & 0.9 & 0.81 \\ 1 & 1.5 & 2.25 \\ 1 & 2.6 & 6.76 \\ 1 & 3.0 & 9.00 \end{pmatrix} \begin{pmatrix} a_1 \\ a_2 \\ a_3 \end{pmatrix} = \begin{pmatrix} 1.0 \\ 1.6 \\ 1.8 \\ 2.0 \\ 1.5 \\ 1.1 \end{pmatrix}.$$

This is of the form

$$\mathbf{A} \cdot \mathbf{a} = \mathbf{b}.$$

As before, we multiply both sides by \mathbf{A}^T and then solve for \mathbf{a} to get

$$\mathbf{a} = (\mathbf{A}^T \cdot \mathbf{A})^{-1} \cdot \mathbf{A}^T \cdot \mathbf{b}.$$

Solving, we find

$$\mathbf{a} = \begin{pmatrix} 0.9778 \\ 1.2679 \\ -0.4090 \end{pmatrix}.$$

So the best quadratic curve fit to the data is

$$x(t) \sim 0.9778 + 1.2679t - 0.4090t^2.$$

The least squares error norm is

$$\|\mathbf{A} \cdot \mathbf{a} - \mathbf{x}\|_2 = 0.0812.$$

- $x = a_1 + a_2 \sin\left(\frac{t}{6}\right) + a_3 \sin\left(\frac{t}{3}\right)$:

This form has applied a bit of intuition. The curve looks like a sine wave of wavelength 6 that has been transposed. So we suppose it is of such a form. The term a_1 is the transposition; the term on a_2 is the fundamental frequency, also known as the first harmonic, that fits in the domain; the term on a_3 is the second harmonic; we have thrown that in for good measure.

We substitute each data point into the assumed form and get the following set of linear equations

$$\begin{aligned} 1.0 &= a_1 + a_2 \sin\left(\frac{0.0}{6}\right) + a_3 \sin\left(\frac{0.0}{3}\right), \\ 1.6 &= a_1 + a_2 \sin\left(\frac{0.7}{6}\right) + a_3 \sin\left(\frac{0.7}{3}\right), \\ 1.8 &= a_1 + a_2 \sin\left(\frac{0.9}{6}\right) + a_3 \sin\left(\frac{0.9}{3}\right), \\ 2.0 &= a_1 + a_2 \sin\left(\frac{1.5}{6}\right) + a_3 \sin\left(\frac{1.5}{3}\right), \\ 1.5 &= a_1 + a_2 \sin\left(\frac{2.6}{6}\right) + a_3 \sin\left(\frac{2.6}{3}\right), \\ 1.1 &= a_1 + a_2 \sin\left(\frac{3.0}{6}\right) + a_3 \sin\left(\frac{3.0}{3}\right). \end{aligned}$$

This can be rewritten as

$$\begin{pmatrix} 1 & 0.0 & 0.0 \\ 1 & 0.1164 & 0.2312 \\ 1 & 0.1494 & 0.2955 \\ 1 & 0.2474 & 0.4794 \\ 1 & 0.4199 & 0.7622 \\ 1 & 0.4794 & 0.8415 \end{pmatrix} \begin{pmatrix} a_1 \\ a_2 \\ a_3 \end{pmatrix} = \begin{pmatrix} 1.0 \\ 1.6 \\ 1.8 \\ 2.0 \\ 1.5 \\ 1.1 \end{pmatrix}.$$

This is of the form

$$\mathbf{A} \cdot \mathbf{a} = \mathbf{b}.$$

As before, we multiply both sides by \mathbf{A}^T and then solve for \mathbf{a} , we get

$$\mathbf{a} = (\mathbf{A}^T \cdot \mathbf{A})^{-1} \cdot \mathbf{A}^T \cdot \mathbf{b}.$$

Solving, we find

$$\mathbf{a} = \begin{pmatrix} 1.0296 \\ -37.1423 \\ 21.1848 \end{pmatrix}.$$

So the best curve fit for this form is

$$x(t) \sim 1.0296 - 37.1423 \sin\left(\frac{t}{6}\right) + 21.1848 \sin\left(\frac{t}{3}\right).$$

The least squares error norm is

$$\|\mathbf{A} \cdot \mathbf{a} - \mathbf{x}\|_2 = 0.1165.$$

Because the error norm for the quadratic curve fit is less than that for the sinusoidal curve fit, the quadratic curve fit is better in this case. A plot of the raw data and the two best fit curves is shown in Fig. 9.17.

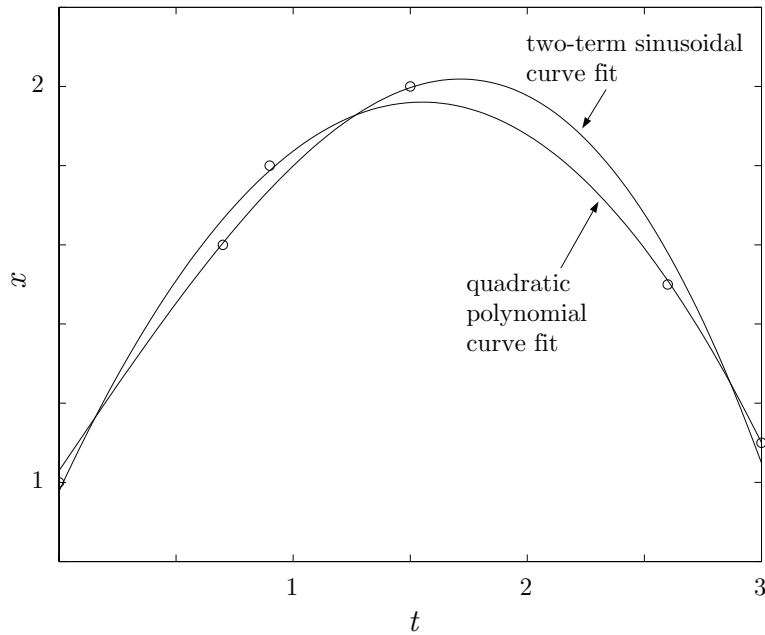

Figure 9.17: Plot of $x - t$ data and two least squares curve fits $x(t) \sim 0.9778 + 1.2679t - 0.4090t^2$, and $x(t) \sim 1.0296 - 37.1423 \sin(t/6) + 21.1848 \sin(t/3)$.

Bibliography

M. M. Abbott and H. C. van Ness, 1989, *Thermodynamics with Chemical Applications*, Second Edition, Schaum's Outline Series in Engineering, McGraw-Hill, New York.

First published in 1972, this is written in the style of all the Schaum's series. It has extensive solved problems and a crisp rigorous style that is readable by undergraduate engineers. It has a chemical engineering emphasis, but is also useful for all engineers.

P. Atkins, 2010, *The Laws of Thermodynamics: a Very Short Introduction*, Oxford University Press, Oxford.

This is a short book by an eminent chemist summarizing the foundations of thermodynamics for an interested general reader.

A. Bejan, 2016, *Advanced Engineering Thermodynamics*, Fourth Edition, John Wiley, Hoboken, New Jersey.

This is an advanced undergraduate text first published in 1988. It gives a modern treatment of the science of classical thermodynamics. It does not confine its attention to traditional engineering problems, and considers applications across biology and earth sciences as well; some readers will find parts of the discussion to be provocative, as received wisdom is occasionally challenged. The thermodynamics of irreversible processes are discussed in detail.

T. L. Bergman, A. S. Lavine, F. P. Incropera, and D. P. DeWitt, 2011, *Fundamentals of Heat and Mass Transfer*, Seventh Edition, John Wiley, New York.

This has evolved since its introduction in 1981 into the standard undergraduate text in heat transfer. The interested thermodynamics student will find the subject of heat transfer builds in many ways on a classical thermodynamics foundation. Especially relevant to thermodynamics are chapters on boiling and condensation, heat exchangers, as well as extensive tables of thermal properties of real materials. The final two authors were the authors of the first edition; their names do not appear on more recent editions.

R. S. Berry, S. A. Rice, and J. Ross, 2000, *Physical Chemistry*, Second Edition, Oxford University Press, Oxford.

This is a rigorous general text in physical chemistry at a senior or first year graduate level. First appearing in 1980, it has a full treatment of classical and statistical thermodynamics as well as quantum mechanics.

L. Boltzmann, 1995, *Lectures on Gas Theory*, Dover, New York.

This is a detailed monograph by the founding father of statistical thermodynamics. This edition is a translation of the original German version, *Gastheorie*, from 1896-1898.

C. Borgnakke and R. E. Sonntag, 2017, *Fundamentals of Thermodynamics*, Ninth Edition, John Wiley, New York.

This classic and popular undergraduate mechanical engineering text, that in earlier editions was authored by J. G. van Wylen and Sonntag, has stood the test of time and has a full treatment of most classical problems. Its first edition appeared in 1965. More recent editions exist, but are missing important material such as Maxwell relations.

M. Born, 1949, *Natural Philosophy of Cause and Chance*, Clarendon Press, Oxford.

This monograph is a summary of the Waynflete Lectures delivered at Oxford University in 1948 by the author, the winner of the 1954 Nobel Prize in physics. The lectures consider various topics, and include an important chapter on thermodynamics with the author's earlier defense of the approach of Carathéodory playing a prominent role.

R. Boyle, 2003, *The Sceptical Chymist*, Dover, New York.

This is a reprint of the original 1661 work of the famous early figure of the scientific revolution.

P. W. Bridgman, 1943, *The Nature of Thermodynamics*, Harvard, Cambridge.

This short monograph by the winner of the 1946 Nobel Prize in physics gives a prosaic introduction to thermodynamics that is directed at a scientifically literate audience who are not interested in detailed mathematical exposition.

H. A. Buchdahl, 1966, *The Concepts of Classical Thermodynamics*, Cambridge, Cambridge.

This short text outlines the basic principles of thermodynamics.

H. B. Callen, 1985, *Thermodynamics and an Introduction to Thermostatistics*, Second Edition, John Wiley, New York.

This advanced undergraduate text, an update of the 1960 original, has an emphasis on classical physics applied to thermodynamics, with a few chapters devoted to quantum and statistical foundations.

S. Carnot, 2005, *Reflections on the Motive Power of Fire*, Dover, New York.

This is a translation of the author's foundational 1824 work on the heat engines, *Réflexions sur la Puissance Motrice du Feu et sur les Machines propres à développer cette Puissance* ("Reflections on the Motive Power of Fire and on Machines Fitted to Develop that Power"). Also included is a paper of Clausius.

Y. A. Çengel and M. A. Boles, 2018, *Thermodynamics: An Engineering Approach*, Ninth Edition, McGraw-Hill, Boston.

This popular undergraduate mechanical engineering text that first appeared in 1989 has most of the features expected in a modern book intended for a large and varied audience.

S. Chandrasekhar, 2010, *An Introduction to the Study of Stellar Structure*, Dover, New York.

This monograph, first published in 1939, on astrophysics is by the winner of the 1983 Nobel Prize in physics. It has large sections devoted to rigorous axiomatic classical thermodynamics in the style of Carathéodory, highly accessible to engineering students, that show how thermodynamics plays a critical role in understanding the physics of the heavens.

R. J. E. Clausius, 2008, *The Mechanical Theory of Heat*, Kessinger, Whitefish, Montana.

This is a reprint of the 1879 translation of the 1850 German publication of the great German scientist who in many ways founded classical thermodynamics.

S. R. de Groot and P. Mazur, 1984, *Non-Equilibrium Thermodynamics*, Dover, New York.

This is an influential monograph, first published in 1962, that summarizes much of the work of the famous Belgian school of thermodynamics. It is written at a graduate level and has a strong link to fluid mechanics and chemical reactions.

E. Fermi, 1936, *Thermodynamics*, Dover, New York.

This short 160 page classic clearly and efficiently summarizes the fundamentals of thermodynamics. It is based on a series of lectures given by this winner of the 1938 Nobel Prize in physics. The book is highly recommended, and the reader can benefit from multiple readings.

R. P. Feynman, R. B. Leighton, and M. Sands, 1963, *The Feynman Lectures on Physics*, Volume 1, Addison-Wesley, Reading, Massachusetts.

This famous series documents the introductory undergraduate physics lectures given at the California Institute of Technology by the lead author, the 1965 Nobel laureate in physics. Famous for their clarity, depth, and notable forays into challenging material, they treat a wide range of topics from classical to modern physics. Volume 1 contains chapters relevant to classical and modern thermodynamics.

J. B. J. Fourier, 2009, *The Analytical Theory of Heat*, Cambridge, Cambridge.

This reprint of the 1878 English translation of the 1822 French original, *Théorie Analytique de la Chaleur* is a *tour de force* of science, engineering, and mathematics. It predates Carnot and the development of the first and second laws of thermodynamics, but nevertheless successfully develops a theory of non-equilibrium thermodynamics fully consistent with the first and second laws. In so doing, the author makes key advances in the formulation of partial differential equations and their solution by what are now known as Fourier series.

J. W. Gibbs, 1957, *The Collected Works of J. Willard Gibbs*, Yale U. Press, New Haven.

This compendium gives a complete reproduction of the published work of the monumental American engineer and scientist of the nineteenth century, including his seminal work on classical and statistical thermodynamics.

W. T. Grandy, 2008, *Entropy and the Time Evolution of Macroscopic Systems*, Oxford, Oxford.

This monograph gives an enlightening description, fully informed by both historical and modern interpretations, of entropy and its evolution in the context of both continuum and statistical theories.

E. A. Guggenheim, 1933, *Modern Thermodynamics by the Methods of Willard Gibbs*, Methuen, London.

This graduate-level monograph was important in bringing the work of Gibbs to a wider audience.

E. P. Gyftopoulos and G. P. Beretta, 2005, *Thermodynamics: Foundations and Applications*, Dover, Mineola, New York.

First published in 1991, this beginning graduate text has a rigorous development of classical thermodynamics.

C. S. Helrich, 2009, *Modern Thermodynamics with Statistical Mechanics*, Springer, Berlin.

This is an advanced undergraduate text aimed mainly at the physics community. The author includes a full treatment of classical thermodynamics and moves easily into statistical mechanics. The author's undergraduate training in engineering is evident in some of the style of the text that should be readable by most undergraduate engineers after a first class in thermodynamics.

J. O. Hirschfelder, C. F. Curtiss, and R. B. Bird, 1954, *Molecular Theory of Gases and Liquids*, Wiley, New York.

This comprehensive tome is a valuable addition to any library of thermal science. Its wide ranging text covers equations of state, molecular collision theory, reactive hydrodynamics, reaction kinetics, and many other topics all from the point of view of careful physical chemistry. Much of the work remains original.

J. R. Howell and R. O. Buckius, 1992, *Fundamentals of Engineering Thermodynamics*, Second Edition, McGraw-Hill, New York.

This is a good undergraduate text for mechanical engineers; it first appeared in 1987.

W. F. Hughes and J. A. Brighton, 1999, *Fluid Dynamics*, Third Edition, Schaum's Outline Series, McGraw-Hill, New York.

Written in the standard student-friendly style of the Schaum's series, this discussion of fluid mechanics includes two chapters on compressible flow that bring together fluid mechanics and thermodynamics. It first appeared in 1967.

- J. H. Keenan, F. G. Keyes, P. G. Hill, and J. G. Moore, 1985, *Steam Tables: Thermodynamic Properties of Water Including Vapor, Liquid, and Solid Phases*, John Wiley, New York.
This is a version of the original 1936 data set that is the standard for water's thermodynamic properties.
- J. Kestin, 1966, *A Course in Thermodynamics*, Blaisdell, Waltham, Massachusetts.
This is a foundational textbook that can be read on many levels. All first principles are reported in a readable fashion. In addition the author makes a great effort to expose the underlying mathematical foundations of thermodynamics.
- R. J. Kee, M. E. Coltrin, and P. Glarborg, 2017, *Chemically Reacting Flow: Theory and Practice*, Second Edition, John Wiley, New York.
This comprehensive text gives an introductory graduate level discussion of fluid mechanics, thermochemistry, and finite rate chemical kinetics. The focus is on low Mach number reacting flows, and there is significant discussion of how to achieve computational solutions.
- C. Kittel and H. Kroemer, 1980, *Thermal Physics*, Second Edition, Freeman, San Francisco.
This is a classic undergraduate text, first introduced in 1970; it is mainly aimed at physics students. It has a good introduction to statistical thermodynamics and a short effective chapter on classical thermodynamics. Engineers seeking to broaden their skill set for new technologies relying on micro-scale thermal phenomena can use this text as a starting point.
- S. Klein and G. Nellis, 2012, *Thermodynamics*, Cambridge, Cambridge.
This is an undergraduate textbook for engineers treating a standard set of topics.
- D. Kondepudi and I. Prigogine, 2015, *Modern Thermodynamics: From Heat Engines to Dissipative Structures*, Second Edition, John Wiley, New York.
This is a detailed modern exposition that exploits the authors' unique vision of thermodynamics with both a science and engineering flavor. The authors, the second of whom is one of the few engineers who was awarded the Nobel Prize (chemistry 1977, for the work summarized in this text), often challenge the standard approach to teaching thermodynamics, and make the case that the approach they advocate, with an emphasis on non-equilibrium thermodynamics, is better suited to describe natural phenomena and practical devices than the present approach, that is generally restricted to equilibrium states.
- K. K. Kuo, 2005, *Principles of Combustion*, Second Edition, John Wiley, New York.
This is a readable graduate level engineering text for combustion fundamentals. First published in 1986, it includes a full treatment of reacting thermodynamics as well as discussion of links to fluid mechanics.
- K. J. Laidler, 1987, *Chemical Kinetics*, Third Edition, Prentice-Hall, Upper Saddle River, NJ.
This is a standard advanced undergraduate chemistry text on the dynamics of chemical reactions. It first appeared in 1965.
- L. D. Landau and E. M. Lifshitz, 2000, *Statistical Physics, Part 1*, Volume 5 of the *Course of Theoretical Physics*, Third Edition, Butterworth-Heinemann, Oxford.
This book, part of the monumental series of graduate level Russian physics texts, first published in English in 1951 from *Statisticheskaya fizika*, gives a fine introduction to classical thermodynamics as a prelude to its main topic, statistical thermodynamics in the spirit of Gibbs.
- B. H. Lavenda, 1978, *Thermodynamics of Irreversible Processes*, John Wiley, New York.
This is a lively and opinionated monograph describing and commenting on irreversible thermodynamics. The author is especially critical of the Prigogine school of thought on entropy production rate minimization.

A. Lavoisier, 1984, *Elements of Chemistry*, Dover, New York.

This is the classic treatise by the man known as the father of modern chemistry, translated from the 1789 *Traité Élémentaire de Chimie*, that gives the first explicit statement of mass conservation in chemical reactions.

G. N. Lewis and M. Randall, 1961, *Thermodynamics and the Free Energy of Chemical Substances*, Second Edition, McGraw-Hill, New York.

This book, first published in 1923, was for many years a standard reference text of physical chemistry.

H. W. Liepmann and A. Roshko, 2002, *Elements of Gasdynamics*, Dover, New York.

This is an influential text in compressible aerodynamics that is appropriate for seniors or beginning graduate students. First published in 1957, it has a strong treatment of the physics and thermodynamics of compressible flow along with elegant and efficient text. Its treatment of both experiment and the underlying theory is outstanding, and in many ways is representative of the approach to engineering sciences fostered at the California Institute of Technology, the authors' home institution.

J. C. Maxwell, 2001, *Theory of Heat*, Dover, New York.

This is a short readable book by the nineteenth century master, first published in 1871. Here, the mathematics is minimized in favor of more words of explanation.

M. J. Moran, H. N. Shapiro, D. D. Boettner, and M. B. Bailey, 2018, *Fundamentals of Engineering Thermodynamics*, Ninth Edition, John Wiley, New York.

This is a standard undergraduate engineering thermodynamics text, and one of the more popular. First published in 1988, it has much to recommend it including good example problems, attention to detail, good graphics, and a level of rigor appropriate for good undergraduate students.

P. M. Morse, 1969, *Thermal Physics*, Second Edition, Benjamin, New York.

This is a good undergraduate book on thermodynamics from a physics perspective. It covers classical theory well in its first sections, then goes on to treat kinetic theory and statistical mechanics. It first appeared in 1964.

I. Müller and T. Ruggeri, 1998, *Rational Extended Thermodynamics*, Springer-Verlag, New York.

This modern, erudite monograph gives a rigorous treatment of some of the key issues at the frontier of modern continuum thermodynamics.

I. Müller and W. Weiss, 2005, *Entropy and Energy*, Springer-Verlag, New York.

This is a unique treatise on fundamental concepts in thermodynamics. The author provide mathematical rigor, historical perspective, and examples from a diverse set of scientific fields.

I. Müller, 2007, *A History of Thermodynamics: the Doctrine of Energy and Entropy*, Springer-Verlag, Berlin.

The author gives a readable text at an advanced undergraduate level that highlights some of the many controversies of thermodynamics, both ancient and modern.

I. Müller and W. H. Müller, 2009, *Fundamentals of Thermodynamics and Applications: with Historical Annotations and Many Citations from Avogadro to Zermelo*, Springer, Berlin.

The author presents an eclectic view of classical thermodynamics with much discussion of its history. The text is aimed at a curious undergraduate who is unsatisfied with industrial-strength yet narrow and intellectually vapid textbooks.

W. Nernst, 1969, *The New Heat Theorem: Its Foundation in Theory and Experiment*, Dover, New York.

This monograph gives the author's exposition of the development of the third law of thermodynamics. It first appeared in English translation in 1917 and was originally published in German.

- S. Paolucci, 2016, *Continuum Mechanics and Thermodynamics of Matter*, Cambridge, New York.
This graduate level monograph has an extensive discussion of how thermodynamics fits within the broader structure of continuum mechanics.
- S. Paolucci, 2019, *Undergraduate Lectures on Thermodynamics*, BreviLiber, South Bend.
This short book gives summaries of traditional thermodynamics lectures with insightful example problems.
- S. Paolucci, 2019, *Undergraduate Lectures on Intermediate Thermodynamics*, BreviLiber, South Bend.
This short book gives summaries of traditional intermediate thermodynamics lectures with insightful example problems.
- W. Pauli, 2000, *Thermodynamics and the Kinetic Theory of Gases*, Dover, New York.
This is a monograph on statistical thermodynamics by the winner of the 1945 Nobel Prize in physics. It is actually derived from his lecture course notes given at ETH Zurich, as compiled by a student in his class, E. Jucker, published in 1952.
- M. Planck, 1990, *Treatise on Thermodynamics*, Dover, New York.
This brief book, that originally appeared in German in 1897, gives many unique insights from the great scientist who was the winner of the 1918 Nobel Prize in physics. It is rigorous, but readable by an interested undergraduate student.
- H. Poincaré, 1892, *Thermodynamique: Leçons Professées Pendant le Premier Semestre 1888-89*, Georges Carré, Paris.
This text of classical undergraduate thermodynamics has been prepared by one of the premier mathematicians of the nineteenth century.
- M. Potter and C. Somerton, 2009, *Thermodynamics for Engineers*, Second Edition, Schaum's Outline Series in Engineering, McGraw-Hill, New York.
First published in 1993, this is a standard contribution in the Schaum format of many solved example problems.
- J. M. Powers, 2016, *Combustion Thermodynamics and Dynamics*, Cambridge, New York.
This graduate level monograph focusing on combustion has a detailed discussion of advanced undergraduate chemical thermodynamics.
- I. Prigogine, 1967, *Introduction to Thermodynamics of Irreversible Processes*, Third Edition, Interscience, New York.
This is a famous book that summarizes the essence of the work of the Belgian school for which the author was awarded the 1977 Nobel Prize in chemistry. This book first appeared in 1955.
- W. J. M. Rankine, 1908, *A Manual of the Steam Engine and Other Prime Movers*, Seventeenth Edition, Griffin, London.
This is an accessible undergraduate text for mechanical engineers of the nineteenth century. It first appeared in 1859. It contains much practical information on a variety of devices, including steam engines.
- L. E. Reichl, 2016, *A Modern Course in Statistical Physics*, Fourth Edition, John Wiley, New York.
This full service graduate text has a good summary of key concepts of classical thermodynamics and a strong development of modern statistical thermodynamics.

- O. Reynolds, 1903, *Papers on Mechanical and Physical Subjects, Volume III, The Sub-Mechanics of the Universe*, Cambridge, Cambridge.
- This volume compiles various otherwise unpublished notes of Reynolds and includes his detailed derivations of general equations of conservation of mass, momentum, and energy employing his transport theorem.
- W. C. Reynolds, 1968, *Thermodynamics*, Second Edition, McGraw-Hill, New York.
- This is an unusually good undergraduate text written for mechanical engineers. The author has wonderful qualitative problems in addition to the usual topics in such texts. A good introduction to statistical mechanics is included as well. This particular edition is highly recommended; the first edition appeared in 1965.
- W. C. Reynolds and P. Colonna, 2018, *Thermodynamics: Fundamentals and Engineering Applications*, Cambridge, New York.
- This is a significant modernization of Reynolds' 1968 text. It maintains the rigor and style of the original and treats new and important topics.
- S. I. Sandler, 2017, *Chemical, Biochemical, and Engineering Thermodynamics*, Fifth Edition, John Wiley, New York.
- This is an advanced undergraduate text in thermodynamics from a chemical engineering perspective with a good mathematical treatment. It first appeared in 1977.
- E. Schrödinger, 1989, *Statistical Thermodynamics*, Dover, New York.
- This is a short monograph written by the one of the pioneers of quantum physics, the co-winner of the 1933 Nobel Prize in Physics. It is based on a set of lectures delivered to the Dublin Institute for Advanced Studies in 1944, and was first published in 1946.
- A. H. Shapiro, 1953, *The Dynamics and Thermodynamics of Compressible Fluid Flow*, Vols. I and II, John Wiley, New York.
- This classic two volume set has a comprehensive treatment of the subject of its title. It has numerous worked example problems, and is written from a careful engineer's perspective.
- J. M. Smith, H. C. van Ness, and M. Abbott, 2004, *Introduction to Chemical Engineering Thermodynamics*, Seventh Edition, McGraw-Hill, New York.
- This is probably the most common undergraduate text in thermodynamics in chemical engineering. It first appeared in 1959. It is rigorous and has went through many revisions.
- A. Sommerfeld, 1956, *Thermodynamics and Statistical Mechanics*, Lectures on Theoretical Physics, Vol. V, Academic Press, New York.
- This is a compilation of the author's lecture notes on this subject. The book reflects the author's stature of a leader of theoretical physics of the twentieth century who trained a generation of students (e.g. Nobel laureates Heisenberg, Pauli, Debye and Bethe). The book gives a fine description of classical thermodynamics with a seamless transition into quantum and statistical mechanics.
- J. W. Tester and M. Modell, 1997, *Thermodynamics and Its Applications*, Third Edition, Prentice Hall, Upper Saddle River, New Jersey.
- First appearing in 1974, this entry level graduate text in thermodynamics is written from a chemical engineer's perspective. It has a strong mathematical development for both classical and statistical thermodynamics.
- C. A. Truesdell, 1980, *The Tragicomic History of Thermodynamics, 1822-1854*, Springer Verlag, New York.
- This idiosyncratic monograph has a lucid description of the history of nineteenth century thermal science. It is written in an erudite fashion, and the reader who is willing to dive into a difficult subject will be rewarded for diligence by gain of many new insights.

- C. A. Truesdell, 1984, *Rational Thermodynamics*, Second Edition, Springer-Verlag, New York.
This is an update on the evolution of classical thermodynamics in the twentieth century. The book itself first appeared in 1969. The second edition includes additional contributions by some contemporaneous leaders of the field.
- S. R. Turns, 2011, *An Introduction to Combustion*, Third Edition, McGraw-Hill, Boston.
This is a senior-level undergraduate text on combustion that uses many notions from thermodynamics of mixtures. It first appeared in 1996.
- S. R. Turns and L. L. Pauley, 2020, *Thermodynamics: Concepts and Applications*, Second Edition, Cambridge, Cambridge.
This is detailed undergraduate book on engineering thermodynamics.
- H. C. van Ness, 1983, *Understanding Thermodynamics*, Dover, New York.
This is a short readable monograph from a chemical engineering perspective. It first appeared in 1969.
- W. G. Vincenti and C. H. Kruger, 1976, *Introduction to Physical Gas Dynamics*, Krieger, Malabar, Florida.
This graduate text on high speed non-equilibrium flows contains a good description of the interplay of classical and statistical mechanics. There is an emphasis on aerospace science and fundamental engineering applications. It first appeared in 1965.
- F. M. White, 2015, *Fluid Mechanics*, Eighth Edition, McGraw-Hill, Boston.
This standard undergraduate fluid text draws on thermodynamics in its presentation of the first law and in its treatment of compressible flows. It first appeared in 1979.
- B. Woodcraft, 1851, *The Pneumatics of Hero of Alexandria*, London, Taylor Walton and Maberly.
This is a translation and compilation from the ancient Greek of the work of Hero (10 A.D.-70 A.D.). The discussion contains descriptions of the engineering of a variety of technological devices including a primitive steam engine. Other devices that convert heat into work are described as well.
- L. C. Woods, 1975, *The Thermodynamics of Fluid Systems*, Clarendon, Oxford.
This graduate text gives a good, detailed survey of the thermodynamics of irreversible processes, especially related to fluid systems in which convection and diffusion play important roles.

Index

- absolute pressure, 39
- absolute temperature, 35, 37, 52, 60, 129, 169, 215, 225
- absolute zero, 15, 36, 238, 298
- acceleration, 171, 260, 319
- acoustics, 386
- adiabatic, 110, 149, 185, 188, 197, 200, 205, 207, 218, 238, 243, 244, 261, 262, 265, 275, 278, 287–290, 293, 313, 314, 318, 325, 347, 351, 378, 380, 381, 385
 - sound speed, 378, 381
- æolipile, 18
- afterburner, 338, 339
- air, 133, 134, 282, 340, 342, 348
- air standard, 282, 339, 340, 342, 348
- Amagat, É, 68
- ammonia, 73, 243, 244
- Amontons, G., 50
- angular momenta principle, 168
- Aquinas, T., 16
- argon, 344, 345
- Aristotle, 12
- Arrhenius, 151
- Arrhenius kinetic rate, 149
- astronomy, 159
- Avogadro's law, 50
- Avogadro's number, 32, 52, 296
- axiom, 15–17, 36, 154, 157, 168, 210, 214, 238, 307, 309
 - angular momenta, 168
 - conservation, 168
 - energy conservation, 169, 181
 - entropy evolution, 169
 - linear momenta, 168
 - mass conservation, 168–170
 - Newton's second, 118–120
- axiomatic approach, 36, 217

- back work ratio, 328, 341
- base load, 204
- Bernoulli principle, 315–320, 323, 390–392
- Bernoulli, D., 315

- biology, 17
- Biot number, 147
- Biot, M., 147
- black swan, 17
- Black, J., 15, 124
- boiler, 204–206, 208, 327, 330, 335
- boiling point, 36, 45, 46
- Boltzmann constant, 35, 295
- Boltzmann, L., 15, 295
- Boulton and Watt steam engine, 21
- Boyle's law, 16, 50
- Boyle, R., 14
- Brayton cycle, 336–338, 341, 342, 344, 347, 348
- Brayton, G., 336
- Bridgman, P., 16

- calculus, 31, 87, 159–161, 165, 248
 - vector, 159
- caloric equation of state, 126, 128, 138, 139, 141, 142, 145, 190, 200, 210, 247
- caloric theory, 111, 124
- calorically imperfect ideal gas, 126, 130, 131, 138, 251, 366
- calorically perfect ideal gas, 126, 127, 250
- calorimetry, 15, 124
- canonical form, 356, 358, 359
- canonical variables, 359–361
- Carathéodory, C., 15, 217
- carbon dioxide, 73, 215
- Carnot cycle, 225, 273–275, 278, 282, 283, 327–330, 342, 347, 351
- Carnot heat engine, 221
- Carnot, S., 15, 221, 273
- Celsius
 - degrees, 36
- Celsius scale, 36
- cesium, 35
- change of state, 34
- Charles' law, 50
- Charles, J., 50, 52
- chemical energy, 117, 149, 339
- chemical equilibrium, 34

chemical kinetics, 151
 chemical potential, 34
 chemistry, 68, 214, 290
 chiller, 353
 Clapeyron, É., 52
 classical thermodynamics, 11–13, 17, 31, 77, 115, 144, 330
 Clausius, R., 15, 17, 114, 216, 233
Clermont, 21
 coefficient of performance, 226, 352, 353
 collision theory, 31
 combustion, 100, 151, 205, 206, 282, 283, 285, 286, 327, 330, 338, 340, 355
Comet, 21
 component efficiency, 324
 compressed liquid, 46, 71, 176, 207
 compressibility, 192, 193
 chart, 64, 65
 factor, 63
 compressible flow, 390
 compressible flow with area change, 393
 compressible fluid mechanics, 385
 compression, 125
 compressor, 180, 198, 199, 319, 325, 338, 339, 341, 344–349, 352
 condenser, 204, 207, 209, 327, 330, 331, 333–336, 351, 352
 conduction, 108
 conjugate variables, 360, 361
 conservation axiom, 168
 conservation of energy, 111, 117, 158, 169, 181, 196
 conservation of mass, 158, 168, 169, 196
 conservation of mass-energy, 155
 conservation of momentum, 196
 continuous, 83
 continuum, 31, 210
 mechanics, 210, 316
 contour, 86
 closed, 87, 111
 integral, 87
 control surface, 30, 188
 control volume, 30, 122, 157, 158, 167, 173–177, 183, 184, 186–192, 196, 208, 309, 310, 314, 350
 convection, 109, 145, 148, 153
 converging-diverging nozzle, 394
 convex, 397
 convex set, 397
 coordinate
 mapping, 368
 transformation, 368, 369
 Coriolis, G., 91
 critical point, 46, 48, 293, 370
 critical pressure, 46, 244
 critical temperature, 46, 67, 244
 critical volume, 371
 crystallography, 159
 curl, 87, 89, 90
 curve fitting
 higher order, 409
 linear, 404
 power law, 407
 cycle, 22, 34, 111, 217
 Brayton, 336–338, 341, 342, 344, 347, 348
 Carnot, 225, 273–275, 278, 282, 283, 327–330, 342, 347, 351
 Otto, 273, 282, 283, 285
 Rankine, 203–205, 208, 209, 327–331, 336, 337, 341, 350
 refrigeration, 350, 351
 steam power, 22, 203, 205
 thermal efficiency, 207
 thermodynamic, 203, 207, 216, 235, 273, 327, 351
 vapor compression, 350
 cyclic, 235
 engine, 223, 233
 integral, 111, 115, 235, 236, 368
 d’Alembert solution, 388
 d’Alembert, J., 388
 Dalton, J., 50, 68
 degrees
 Celsius, 36
 Fahrenheit, 37
 Kelvin, 35
 Rankine, 36, 37
 density, 12, 32, 35, 39, 40, 50, 62, 64, 145, 150, 166, 169, 171, 172, 186, 194, 211, 212, 242, 260, 315, 320, 384, 385
 derivative, 82, 159, 161, 163, 170, 182, 270, 373, 380, 381, 386, 388, 389, 397
 first, 293
 material, 170, 172, 212, 386
 partial, 82, 83, 127, 163, 291, 292, 363, 370, 388
 second, 293, 343, 370
 space, 387
 time, 144, 161, 180, 184, 271, 387
 total, 82, 127, 179
 Descartes, R., 81

- deviatoric stress tensor, 210
- diatomic gas, 132–135, 201
- Diesel engine, 22
- differential, 41, 172, 310, 316
 - exact, 81, 83, 86, 356
 - inexact, 84, 110, 111
 - total, 82, 172
- differential equation, 30
 - first order, 146, 151
 - non-linear, 151, 267
 - ordinary, 24, 146, 151, 267
 - partial, 210
 - second order, 24
- diffuser, 196, 197, 313–315
- disorder, 215
- dissociation, 62, 133
- distance, 31, 39, 91, 92, 101, 107, 111, 118, 119, 180, 268, 385, 403
- district heating and cooling, 204
- divergence, 89, 90, 171, 172
- divergence theorem, 159–161, 170, 173, 182, 184
- dot product, 92
- double interpolation, 76
- drag, 24, 26–28, 81, 266, 268, 269
- dynamics, 397
- efficiency
 - component, 324
 - thermal, 207, 222
- Einstein, A., 16, 17, 154
- elasticity
 - modulus, 211
- electric energy, 117
- electron, 134
- energy, 12–16, 18, 24–28, 39, 61, 71, 81, 92, 108–112, 116–119, 121, 126, 132–135, 139, 140, 148, 154, 157, 158, 169, 179, 187–190, 192, 193, 196–203, 205–208, 210–217, 222, 223, 225, 226, 228–231, 233, 241, 246, 252, 253, 287, 290–292, 294, 297, 298, 300, 301, 306, 309, 311, 314–318, 320, 324, 326, 338, 339, 348, 350, 376, 378, 385, 386, 393
 - chemical, 149
 - chemical, 117, 149, 153, 339
 - conservation of, 15, 111, 117, 291
 - electric, 117
 - evolution of, 117
 - internal, 71, 117–119, 121, 130, 135, 136, 138, 143, 149, 187, 245, 256, 276, 296, 297, 358, 393
 - kinetic, 12, 14, 24–26, 28, 81, 116–118, 132, 133, 187, 193, 196–200, 202, 203, 217, 225, 246, 294, 300, 314, 315, 318, 320, 324, 338, 339, 348, 390, 392, 393
 - magnetic, 117
 - mechanical, 12, 16, 18, 24, 25, 27, 28, 81, 116, 140, 197, 198, 222, 246, 315, 320, 339
 - potential, 24–26, 28, 81, 116, 117, 119, 133, 140, 179, 187, 192, 196–200, 202, 203, 217, 246, 314, 318, 320, 339
 - rotational, 133
 - specific internal, 121
 - thermal, 12, 16, 18, 28, 81, 108, 110, 112, 116–118, 139, 148, 149, 199, 205–207, 214, 222, 223, 226, 228, 241, 246, 253, 294, 315, 316, 339, 376, 390, 392
 - total, 81, 117, 121, 144, 154, 179, 180, 184, 187, 246
 - translational, 132
 - vibrational, 133, 135, 201
- energy conservation principle, 169, 181
- engine
 - automobile, 233
 - Diesel, 22
 - gasoline, 22
 - jet, 157, 233
 - steam, 92
- enthalpy, 71, 122, 123, 126, 135–137, 182, 187, 190, 192, 193, 248, 326, 359, 360, 401
 - specific, 122
 - total, 122, 184, 185, 187, 188
- entropy, 15, 71, 111, 169, 214–216, 233, 234, 236–239, 241–243, 245–249, 251–254, 256, 265, 266, 271, 272, 287–295, 298, 300–303, 306, 309, 312, 360, 367, 375, 376, 378, 382, 386
 - ideal gas, 249
 - information, 306
 - irreversible production, 309
 - mixture, 291
 - randomness, 294
 - thermo-mechanical mixing, 287
- entropy evolution principle, 169
- epidemiology, 151, 153
- epigraph, 397
- equation of state, 50, 66, 71, 81, 205, 210, 365, 368, 378, 386
 - caloric, 126, 128, 138, 139, 141, 142, 145, 210, 247, 371
 - non-ideal, 62

Redlich-Kwong, 63
 tabular, 65
 thermal, 49, 50, 62, 65, 126, 142, 210, 367, 371
 van der Waals, 62, 369–377
 equilibrium, 33–35, 43, 71, 92, 139, 146, 178, 190, 215, 218, 263, 267–270, 287, 289–291, 294, 306, 307
 chemical, 34
 mechanical, 33, 41, 101, 260, 262, 266, 269, 287
 pressure, 263
 thermal, 33, 35, 153, 287, 290
 Euclid, 16, 17, 36
 Euler method, 151
 evolution of energy, 117
 exact differential, 81, 83, 86, 179, 356
 exothermic, 149, 150
 explicit Euler method, 267
 extensive property, 33, 116, 118, 166, 169, 179
 extrapolation, 74

 Fahrenheit
 degrees, 37
 Fermi, E., 16
 Feynman, R., 134
 field, 82, 87
 electric, 107
 gravitational, 26, 27, 111, 179, 319, 320
 scalar, 82, 88
 temperature, 294
 vector, 89, 90
 velocity, 171, 172
 finite difference, 267, 381, 382
 first harmonic, 411
 first law of thermodynamics, 15, 36, 81, 111, 114–120, 122–125, 128, 129, 136, 139, 140, 142, 144, 145, 154, 169, 179, 181, 185, 187, 188, 200, 202, 206–208, 212, 214, 217, 222, 223, 227, 228, 231, 233, 235, 244, 246, 252, 253, 265, 272, 273, 276, 277, 280–283, 288, 290, 314, 325, 326, 367, 374
 flow, 31, 157, 220, 315, 386, 390, 394
 compressible, 318, 385, 390
 fluid, 30
 incompressible, 318, 323
 inviscid, 220
 isentropic, 386
 one-dimensional, 171, 385
 stagnation, 390
 steady, 393
 supersonic, 394
 unsteady, 316
 fluid, 30, 40–42, 45, 67, 73, 99, 109, 111, 124, 157, 158, 166, 167, 169–172, 177, 179–181, 186, 188, 197–199, 205, 207, 211, 212, 220, 259, 260, 272, 275, 315, 319, 320, 324, 327, 330, 334, 338–340, 344, 385, 390, 393
 fluid mechanics, 157, 166, 211, 330
 compressible, 212, 385
 force, 12, 24, 26–28, 30, 31, 37–39, 41, 48, 61, 62, 64, 77, 78, 81, 91, 92, 101, 106, 107, 118–120, 133, 166, 168, 180, 211, 246, 259, 260, 266, 268, 269, 339, 348, 350, 369, 385
 body, 37
 Fourier’s law, 108, 211, 212
 Fourier, J., 108, 212
 Fowler, R., 36
 free body diagram, 60
 free energy
 Gibbs, 360, 362, 402
 Helmholtz, 360, 361, 401
 freezing point, 36
 frequency, 411
 friction, 118, 207, 220, 346
 Fulton, R., 21
 fundamental theorem for line integrals, 87
 fundamental theorem of calculus, 86, 159, 160, 165
 furnace, 157, 233

 Galileo, G., 14
 gas, 45, 107
 diatomic, 132–135, 201
 monatomic, 127, 128, 132, 135
 noble, 127, 128
 gauge pressure, 39, 40, 320
 Gauss’s theorem, 159
 Gay-Lussac, J., 52
gedankenexperiment, 43, 214
 general transport theorem, 166
 Giauque, W., 16
 Gibbs entropy formula, 295
 Gibbs equation, 246–249, 254, 255, 257, 317, 328, 338, 356, 358–360, 364, 365, 375, 378, 386
 first, 247
 second, 248
 Gibbs free energy, 360, 362, 402

Gibbs, J., 15, 246
 governing equations of continuum mechanics, 210
 gradient, 87, 88, 108, 160
 pressure, 260
 temperature, 108
 gravity, 212, 390

 heat, 11, 12, 15, 29, 45, 108–111, 117, 123, 154,
 169, 214, 229, 235, 327, 330, 338, 340,
 353
 conduction, 212
 latent, 123, 147, 245
 sensible, 123, 245
 sign convention, 109
 heat capacity
 specific, 124, 364
 heat death, 307
 heat diffusion, 108, 386
 heat engine, 15
 Carnot, 221
 heat exchanger, 157, 199
 counterflow, 200
 heat flux vector, 108, 210
 heat pump, 228, 352
 Carnot, 226
 heat transfer, 31, 108, 110, 116, 121–123, 128,
 130, 136, 138, 143, 146, 148, 151, 154,
 166, 169, 179, 181–183, 185, 187, 188,
 192, 196, 198, 199, 202, 204–208, 212,
 223, 225, 229, 238, 239, 241, 245, 256,
 275, 277, 281, 283, 285, 288, 310, 312,
 314, 316, 330, 350, 374–376
 coefficient, 144
 convective, 145, 151
 irreversible, 239
 isobaric, 351
 isothermal, 351
 radiative, 109
 reversible, 239, 246, 309
 Helmholtz free energy, 360, 361, 401
 Helmholtz, H., 15, 114
 Hero of Alexandria, 14, 18
 Hess, G., 15

 ideal gas, 14, 50, 52–54, 57–62, 64–66, 71, 95,
 97, 126, 127, 129, 130, 135–137, 193,
 194, 201, 210, 247, 249–252, 255–258,
 263, 268, 285–288, 296, 297, 311, 340,
 365, 366, 373–375, 380, 382
 calorically imperfect, 130, 131, 138, 251,
 366
 calorically perfect, 127, 250
 entropy of, 249
 isentropic relations, 257
 ideal gas tables, 135
 incompressibility, 212
 incompressible, 125, 150, 171, 211, 254, 290,
 318, 319, 323, 391, 392
 incompressible liquid, 254
 incompressible solid, 254
 industrial revolution, 22
 inertia, 61, 77, 211, 269
 inexact differential, 84, 110, 111
 inflection point, 371
 information, 17
 information entropy, 306
 information theory, 305
 integral, 82, 84, 87, 104, 116, 159, 161, 162, 170,
 173, 182–184, 186, 201, 237, 240, 318
 cyclic, 111, 115, 235, 236, 368
 surface, 160, 161, 163, 165, 167, 170, 182,
 184
 volume, 159, 161, 165, 167, 170, 184
 intensive property, 33, 49, 52, 77, 78
 internal energy, 71, 117–119, 121, 130, 135, 136,
 138, 143, 149, 187, 245, 256, 276, 296,
 297, 358, 393
 interpolation, 73–75, 79, 208, 243, 282, 382
 double, 74, 76, 206
 linear, 73–76, 243
 single, 74
 ion, 134
 ionization, 133
 irreversibility, 312
 irreversible, 220
 entropy production, 309
 process, 220, 239, 240
 work, 223
 isentrope, 238, 244, 256, 258, 259
 isentropic, 243, 244, 257–260, 262, 264, 267,
 271–273, 275, 276, 282–286, 319, 324–
 328, 335, 337, 341, 345–347, 349, 350,
 352, 367, 386, 390, 392
 isobar, 57, 71, 256, 338, 352, 371
 isobaric, 34, 44, 45, 48, 50, 96, 97, 99, 104, 123,
 125, 136, 244, 245, 327, 332, 337, 344,
 351
 isochore, 255, 256
 isochoric, 34, 61, 96, 100, 104, 122, 124, 142,
 144, 252, 253, 265, 282, 283, 286, 288
 isolated system, 29
 isotherm, 78, 79, 248, 258, 259, 370, 371

isothermal, 14, 34, 45, 50, 51, 95, 97, 245, 258,
 275, 278, 319, 351, 362, 363, 373, 375,
 376, 379–381
 isothermal sound speed, 379

 Jacobian determinant, 368
 Jacobian matrix, 368, 369
 Joule, J., 15, 112

 Kalman filter, 407
 Kelvin
 degrees, 35
 Kelvin scale, 36
 kinetic energy, 12, 14, 24–26, 28, 81, 116–118,
 132, 133, 187, 196–200, 202, 203, 217,
 225, 246, 294, 300, 314, 315, 318, 320,
 324, 338, 339, 348, 390, 393
 kinetic rate
 Arrhenius, 149
 kinetics
 chemical, 151

 Lagrange multiplier, 291–293, 300–302, 304
 Lagrange, J., 159, 291
 Laplace, S., 380
 latent heat, 123, 147, 245
 law of mass action, 149
 least squares, 402, 403, 412
 unweighted, 403
 weighted, 405
 Legendre transformation, 359, 360, 363, 401,
 402
 Legendre, A., 359
 Leibniz’s rule, 161
 Leibniz, G., 81, 161
 length, 12, 31, 32, 35, 41, 107, 168, 268, 384,
 385
 linear interpolation, 73–76, 243
 linear momenta principle, 168
 linearized analysis of differential equations, 269
 liquid, 45, 46, 247
 compressed, 46, 71, 176, 207
 incompressible, 254
 saturated, 44, 46, 66, 71, 74, 121, 207, 248
 subcooled, 352

 Müller, I., 14
 Mach number, 390, 391, 393, 394
 magnetic energy, 117
 manometer, 40, 41
 manometry, 40
 Mariotte’s law, 50

 Mariotte, E., 50
 mass, 12, 24, 29, 30, 33, 35, 43, 45, 47, 52, 53,
 61, 67–70, 81, 92, 111, 118, 119, 121,
 123, 124, 129, 136, 139, 140, 143, 147,
 150, 154, 155, 157, 158, 166, 168–171,
 173–177, 183, 186, 187, 189, 191, 193,
 194, 196, 198–200, 204, 205, 210–215,
 231, 237, 243, 246, 252, 263, 264, 266,
 270–272, 276, 278, 283, 287, 288, 290,
 306, 309–311, 322, 323, 325, 326, 330,
 333, 334, 348, 378, 386, 393, 394
 flow rate, 174, 177, 186, 205, 330, 334, 348
 mass conservation principle, 168–170
 material
 derivative, 170, 172, 212
 region, 168, 169, 171
 surface, 167
 volume, 167, 169, 172, 179–181
 mathematics, 86, 157, 159, 166, 218, 367, 368
 matter, 157
 maximum, 17, 151, 152, 283, 285, 286, 293, 342–
 344, 407
 Maxwell relations, 15, 355, 356, 360, 363
 Maxwell, J., 15, 134, 355
 Mayer’s relation, 127, 138, 366, 377
 Mayer, J., 15, 112
 mean free path, 12, 31, 32
 mean molecular speed, 32
 mechanical energy, 12, 16, 18, 24, 25, 27, 28, 81,
 116, 140, 197, 198, 222, 246, 315, 320,
 339
 mechanical equilibrium, 33, 41, 101, 260, 262,
 266, 269, 287
 mechanical equivalent of heat, 15, 111
 mechanics, 14, 16, 114, 154, 159, 168
 continuum, 210, 316
 fluid, 157, 166, 211, 212, 330, 385
 Newtonian, 16, 28, 31, 91, 118
 quantum, 134, 135, 295
 solid, 135
 statistical, 15, 134, 135
 methane, 73, 215
 method of least squares, 402
 Michelson-Morley experiment, 17
 minimum, 17, 81, 228, 397
 mixing, 290
 entropy of, 287, 290
 mixture, 290, 291
 Amagat, 68
 Dalton, 68
 mixture entropy, 292

mixture theory, 68, 290
 modulus of elasticity, 135
 molecular diameter, 32
 molecular mass, 32, 53, 54, 149, 297
 molecule, 134
 momenta, 210
 momentum, 31, 196, 315, 350, 378, 385, 386, 393
 momentum flux, 350
 monatomic gas, 127, 128, 132, 135

 nano-scale heat transfer, 31
 Nernst, W., 16, 238
 Newcomen, T., 15
 Newton's law of cooling, 109, 144
 Newton's method, 301
 Newton's second law, 12, 24, 37, 41, 77, 154, 168, 246, 259, 266, 350
 Newton, I., 12, 14, 15, 17, 81, 144, 161, 380
 Newtonian fluid, 211
 Newtonian mechanics, 12, 118
 nitrogen, 48, 73
 noble gas, 127, 128
 non-equilibrium thermodynamics, 15, 34, 144, 306
 non-ideal gas, 53, 95, 247, 369
 non-linear, 150, 151, 403
 algebra, 194, 311
 ordinary differential equations, 267
 norm, 403, 412
 nozzle, 196, 197, 324, 339, 350, 394, 395
 converging-diverging, 394
 subsonic, 394
 supersonic, 394

 Onnes, H., 16, 122
 Onsager reciprocity, 15
 Onsager, L., 15, 16
 optics, 159
 Otto cycle, 273, 282, 283, 285
 Otto, N., 282

 pandemic, 153
 Papin, D., 15, 18
 partial derivative, 82, 83, 127, 291, 292, 363, 370, 388
 partial differential equation, 210
 partial pressure, 68
 partial volume, 68
 partition function, 304
 Pascal, B., 40
 path-dependent, 92, 94, 110, 111, 116, 124, 206, 309
 path-independent, 82, 83, 86, 87, 94, 116, 138, 236, 237
 phase, 33, 329, 341
 gas, 329, 341
 phase boundaries, 33
 physics, 17, 24, 94, 132, 134, 135, 157, 159, 170, 178, 214, 215, 261, 269, 397, 403
 Planck, M., 16
 point of inflection, 370
 Poisson's ratio, 211
 polytropic exponent, 95
 polytropic process, 94–97, 104, 129, 258, 276
 Popper, K., 307
 position, 12
 potato, 29, 145–148, 150–153
 potential energy, 24–26, 28, 81, 116, 117, 119, 133, 140, 179, 187, 192, 196–200, 202, 203, 217, 246, 314, 318, 320, 339
 power, 11, 12, 18, 21, 22, 92, 202–205, 207–209, 228, 233, 283, 327, 330, 331, 333, 334, 336–338, 341, 344, 345, 347, 352, 354
 electric, 207
 power law curve fitting, 407
 Power, H., 50
 pressure, 18, 30, 31, 33–36, 39–46, 48–50, 57, 59, 61, 64–66, 68–71, 74, 76–79, 92, 99, 101, 105–107, 125, 127, 138, 142, 143, 180, 182, 191–193, 205, 207, 246, 251, 260–263, 266, 268, 269, 272, 273, 285–288, 313, 315, 319, 320, 322, 330, 332, 334, 338, 342, 344, 346, 350, 370, 382, 392
 absolute, 39
 critical, 46, 244
 gauge, 39, 40, 320
 partial, 68
 saturation, 46
 stagnation, 391, 392
 Prigogine, I., 16
 probability, 17, 135, 295, 298
 process, 17, 34, 45, 54, 61, 77, 79, 93, 94, 96–99, 101, 104, 105, 110, 116, 117, 122, 130, 139, 140, 142, 143, 193, 217, 220, 290, 313, 315, 318, 346, 376
 adiabatic, 110, 313, 347
 combustion, 330, 340
 cooling, 344
 cyclic, 222
 expansion, 100
 heat transfer, 108, 148, 376
 heating, 125, 344

- irreversible, 220, 239, 240
- isentropic, 325, 328, 346
- isobaric, 44, 96, 123, 136
- isochoric, 61, 96, 100, 122, 142, 144
- isothermal, 50, 51, 95, 375
- non-equilibrium, 107
- polytropic, 94–97, 104, 129, 258, 276
- quasi-equilibrium, 210
- reversible, 220, 236, 238–240, 242, 247, 313
- reversible, adiabatic, 243, 262, 318
- sublimation, 71
- two-step, 97
- property, 33, 34, 49, 208
 - extensive, 33, 116, 118, 166, 169, 179
 - intensive, 33, 49, 52, 77, 78, 237, 288
- pump, 14, 18, 157, 180, 198, 199, 203, 205, 207, 233, 319, 325, 327–332, 336, 352
- pure substance, 43
- quality, 47, 49, 66, 67, 70, 71, 74, 76, 101, 121, 142, 143, 279
- quantum effects, 11
- quantum mechanics, 134
- quasi-equilibrium, 210
- R-134a refrigerant, 73, 352
- R-410a refrigerant, 73
- radiation, 35, 109
- ramjet, 339
- random, 81, 118, 294, 298
- randomness, 215, 242, 294, 298, 302
- Rankine
 - degrees, 36
- Rankine cycle, 203–205, 208, 209, 327–331, 336, 337, 341, 350
 - reheat, 330
- Rankine, W., 110, 327
- rarefied gas dynamics, 31
- ratio of specific heats, 127, 367, 381
- reaction, 149–153
 - chemical, 149
 - dynamics, 149
- reaction progress, 149
- reciprocity
 - Onsager, 15
- Redlich-Kwong equation of state, 63, 141
- reduced pressure, 64
- reduced temperature, 64
- refrigeration cycle, 350, 351
- refrigerator, 228, 350, 353
 - capacity, 352
 - Carnot, 226, 353
- Regnault, H., 52
- reheat, 330–334
- reversible, 233
 - process, 220, 236, 238–240, 242, 247, 313
- reversible work, 223
- Reynolds transport theorem, 166, 167, 170, 173, 182
- Reynolds, O., 166
- Rocket*, 21
- rotational energy, 133, 197
- saturated liquid, 44, 46, 66, 71, 74, 121, 207, 248
- saturated vapor, 45, 46, 66, 121, 142, 143, 248, 278
- saturation pressure, 46, 48
- saturation temperature, 44–46, 48, 71
- Savery, T., 15
- scalar, 92, 160, 164, 181, 212, 402
 - field, 87
- scalar field, 82, 88
- Schrödinger, E., 16
- second harmonic, 411
- second law, 312
- second law of thermodynamics, 15, 16, 36, 169, 208, 214–219, 222–224, 226, 228–230, 233, 235, 236, 239–242, 253, 273, 302, 309, 313, 316
 - Carathéodory statement, 218
 - Clausius statement, 216
 - entropy-based statement, 215
 - Kelvin-Planck statement, 216, 235
- sensible heat, 123, 245
- shaft work, 180, 185, 188, 189, 206
- Shannon, C., 305
- shock wave, 195, 386, 392
- SI (Système International), 35
- simple compressible substance, 48, 49, 246
- Simpson’s rule, 100
- single interpolation, 74
- singularity, 394, 407
- slope, 57, 59, 172, 255, 256, 258, 259, 261, 338, 370, 371, 397, 398
- Snow, C., 214
- social distance, 153
- social distancing, 151
- social network, 153
- solid, 211, 212, 247, 290
 - incompressible, 254
- solid mechanics, 135
- Sommerfeld, A., 36

sonic, 394
 sound speed, 192, 367, 378, 380, 381, 385, 390
 adiabatic, 378, 380–382, 385
 isentropic, 367, 390
 isothermal, 379–382
 space, 48, 50, 78, 79, 167, 210, 357, 383, 387
 space shuttle, 394, 395
 spacecraft, 195
 species, 149
 specific heat, 123–126, 138, 141, 149, 285, 290, 364
 at constant pressure, 125
 at constant volume, 124
 specific heat capacity, 124
 specific internal energy, 121
 specific volume, 39, 41, 45, 46, 53, 66, 68, 69, 71, 118, 264
 specific work, 92
 speed of light, 154
 stagnation, 390
 flow, 390
 point, 390
 pressure, 391, 392
 temperature, 390, 391
 state, 33, 34, 36, 44, 45, 49, 54, 59, 60, 66, 76–79, 84, 91–95, 97–99, 101, 102, 104, 106, 107, 111, 116, 119, 120, 126, 129, 138, 140, 142, 143, 145, 176, 190, 193, 198, 206–208, 216, 220, 233, 239, 242–244, 249, 250, 263, 264, 278, 279, 283, 285–290, 295, 297, 298, 300, 301, 306, 314, 320, 325, 326, 331, 332, 334, 335, 345, 352, 373, 374, 381, 387
 equilibrium, 33, 178, 218, 269, 270
 reference, 121
 statics, 12
 statistical mechanics, 15, 134
 statistical thermodynamics, 15
 statistics, 17
 steady state, 174–176, 178, 198, 205, 310
 steam digester, 15
 steam engine, 15, 18, 21, 92, 214, 225
 Boulton and Watt, 21
 steam power cycle, 203, 205
 steam tables, 66, 142, 193, 202, 205, 206, 242, 315, 334, 374–376, 381
 Stefan-Boltzmann constant, 109
 Stephenson, R., 21
 Stokes' assumption, 211
 Stokes' theorem, 87
 strain, 135, 211
 strain rate, 211
 stress, 135, 180, 210, 211, 392
 deviatoric, 210, 211
 sublimation, 48, 71, 242
 subsonic, 394
 subsonic nozzle, 394
 superheated vapor, 46, 49, 71, 79
 supersonic, 394
 supersonic nozzle, 394
 surface, 167
 surroundings, 29, 92, 108, 118, 119, 144, 153, 154, 207, 216, 220, 228, 242, 252–254, 262, 266, 283, 287, 288, 290, 327, 330, 376
 system, 12, 17, 29, 30, 33, 34, 49, 81, 92, 98, 107–111, 116–120, 130, 146, 149–151, 154, 157, 175, 190, 205, 210, 213, 215, 216, 218, 220, 222, 223, 225, 226, 290, 309, 310, 318, 330, 352, 353, 376
 boundary, 29, 108, 111, 140, 154
 combined, 140, 223
 isolated, 29, 154, 155, 215
 thermodynamic, 29
 tabular equation of state, 65
 Taylor series, 195, 270, 391, 393
 temperature, 15, 16, 30, 31, 33–37, 44–46, 48, 50, 52, 59–62, 64–67, 71–74, 77, 81, 99, 108, 118, 123–125, 127–130, 132–136, 139, 141–145, 147–153, 169, 181, 189–191, 193–195, 201, 215, 225–227, 229–231, 233, 238, 241, 242, 245, 251–253, 261, 262, 272, 273, 278, 283–288, 290–292, 294, 298, 313, 315, 316, 326, 330, 332, 334, 342–345, 347–351, 360, 370, 376, 381, 392
 absolute, 35, 37, 52, 60, 129, 169, 215
 critical, 46, 67, 244
 saturation, 44–46, 71
 stagnation, 390, 391
 tensor, 210, 211
 stress, 211
 theology, 16
 thermal conductivity, 108, 147, 148, 212
 thermal efficiency, 207, 222
 thermal energy, 12, 16, 18, 28, 81, 108, 110, 112, 116–118, 139, 148, 149, 199, 205–207, 214, 222, 223, 226, 228, 241, 246, 253, 294, 315, 316, 339, 376, 390
 thermal equation of state, 49, 50, 62, 65, 126, 142, 210

thermal equilibrium, 33, 35, 153, 287
 thermal radiation, 109
 thermochemistry, 149
 thermodynamic cycle, 203, 207, 216, 235, 273, 327, 351
 thermodynamic system, 29
 thermodynamics, 12, 15–17, 22, 28, 30, 31, 33, 34, 36, 37, 39, 53, 81, 92, 94, 108, 110, 111, 116, 117, 121, 126, 132, 145, 157, 169, 179, 181, 187, 208, 210, 212–221, 224, 226, 233, 235, 236, 238–240, 244, 246, 253, 265, 273, 288, 294, 295, 302, 306, 307, 309, 315, 355, 358, 359, 367, 374, 380, 385, 397, 401
 classical, 11–13, 17, 31, 77, 115, 144, 330
 equilibrium, 34, 108, 210
 non-classical, 17
 non-equilibrium, 15, 34, 108, 144, 306, 309
 statistical, 15
 thermostatics, 12
 third law of thermodynamics, 238
 Thompson, B. (Count Rumford), 15, 111
 Thomson, W. (Lord Kelvin), 11, 15, 307
 throttling device, 192, 196
 throttling valve, 351
 thrust, 338, 339, 348, 350
 time, 12, 24–27, 31–35, 77, 81, 92, 108, 144–147, 150, 159, 161–163, 168–170, 172, 178–180, 184, 186, 187, 190, 191, 206, 210, 213, 215, 241, 267–269, 271, 295, 350, 381, 383–385, 387
 time constant, 146, 147, 178, 190, 191
 time-dependency, 144
 Torricelli's formula, 319
 Torricelli, E., 319
 total derivative, 82, 127, 179
 total differential, 82, 172
 total energy, 81, 117, 121, 144, 154, 179, 180, 184, 187, 246
 total enthalpy, 122, 184, 185, 187, 188
 Towneley, R., 50
 transformation, 36
 coordinate, 367
 Legendre, 359, 360, 397
 translational kinetic energy, 132
 transport theorem
 general, 166
 Reynolds, 166, 167, 170, 182
 transpose, 86
 trapezoidal method, 101
 triple point, 35, 36, 48, 67, 71, 226
 Truesdell, C., 14, 114
 turbine, 157, 180, 197, 198, 200–202, 204, 206, 207, 312, 314, 319, 324, 327, 328, 330–332, 334, 335, 338, 339, 341, 346–348
 steam, 202, 312, 314
 turbojet, 338, 339, 348
 two-phase mixture, 33, 46, 47, 49, 66, 69, 70, 74, 76, 99, 121, 142, 239, 247, 329, 331, 335
 universal gas constant, 52, 132
 universe, 29, 241–243, 252–254, 266, 287, 289, 306, 307, 376
 isolated, 306
 University of Notre Dame, 22, 23, 112, 114, 205, 206, 209, 275, 353, 354, 362, 395
 power plant, 23, 205, 353
 vacuum, 107
 vacuum pump, 14
 valve, 188, 189, 192, 193, 311
 expansion, 352
 van der Waals equation of state, 62
 van der Waals gas, 141, 369–373, 375–377
 van der Waals, J., 16, 63
 van't Hoff, J., 16
 vapor, 45
 saturated, 45, 46, 66, 121, 142, 143, 248, 278
 superheated, 46, 71, 79
 vapor compression cycle, 350
 vapor dome, 62, 63, 65, 78, 79, 128, 243, 245, 248, 369, 371, 372
 vapor pressure curve, 46
 variables
 canonical, 359–361
 conjugate, 360, 361
 vector, 86, 87, 92, 108, 155, 159, 160, 163, 180, 181, 186, 210, 211, 403, 404
 column, 86
 distance, 92
 field, 87, 89, 90, 171
 force, 12, 92
 gradient, 88
 heat flux, 108
 position, 12
 row, 86
 velocity, 155, 166, 171
 velocity, 14, 25, 26, 30, 118–120, 154, 155, 162, 163, 166, 169–172, 180, 186, 192, 196, 210, 211, 266, 268, 315, 319–323, 338, 348, 350, 384, 385, 387, 390, 392, 394

field, 171
 gradient, 172
 vibrational energy, 133, 135, 201
vis viva, 81
 viscosity, 212, 220, 386
 volume, 29, 30, 33, 34, 39, 41, 44, 45, 48, 50,
 55, 57, 60–62, 67–70, 93, 99, 105, 121,
 142, 145, 146, 159–168, 170, 173, 184,
 186, 189, 231, 246, 262, 287, 352, 369
 critical, 371
 flow rate, 352
 partial, 68
 specific, 39, 41, 45, 46, 53, 66, 68, 69, 71,
 118, 264
 von Guericke, O., 14

 water, 14, 33, 35, 36, 43–45, 47–49, 66, 69–72,
 74–79, 98–100, 111, 121, 139–144, 146–
 148, 175, 176, 204, 205, 207, 209, 213–
 215, 226, 231, 242, 244, 245, 248, 256,
 261–264, 278, 279, 282, 287, 320, 322–
 324, 327, 330, 334, 336, 353, 371–373,
 384
 Watt, J., 15, 18, 124
 wave equation, 388, 389
 wavelength, 411
 welding, 133
 William of Occam, 16
 Wilson, K., 16
 work, 12, 15, 22, 29, 39, 49, 50, 91–98, 101, 104,
 105, 107, 108, 110, 111, 114, 116–118,
 120, 121, 125, 129, 130, 138, 140, 142,
 149, 154, 166, 169, 179, 180, 182, 183,
 185, 187, 188, 192, 197, 200, 201, 205,
 207, 212, 214–218, 221–223, 225, 226,
 229, 233, 235, 241–243, 246, 256, 265,
 267, 272, 275–277, 281, 285, 288, 312,
 325–328, 337, 338, 341, 343, 344, 346,
 348–351, 359, 360, 375
 chemical, 49
 electric, 49, 107
 irreversible, 223
 magnetic, 49
 reversible, 223
 shaft, 180, 185, 188, 189, 206
 sign convention, 92
 surface force, 107
 tensile force, 107

 Young, T., 12

 zeroth law of thermodynamics, 36